



S-24C32C/64C H Series

FOR AUTOMOTIVE 105°C OPERATION 2-WIRE SERIAL E²PROM

www.sii-ic.com

© SII Semiconductor Corporation, 2010-2015

Rev.2.1_01_H

The S-24C32C/64C H series is a high temperature operation 2-wire serial E²PROM for automotive components. The S-24C32C/64C H series has the capacity of 32 K-bit and 64 K-bit, and the organization is 4096 words × 8-bit, 8192 words × 8-bit, respectively. Page write and sequential read are available.

■ Features

- Operating voltage range: Read 2.5 V to 5.5 V
 Write 2.5 V to 5.5 V
- Page write: 32 bytes / page
- Sequential read
- Operation frequency: 400 kHz ($V_{CC} = 2.5\text{ V to }5.5\text{ V}$)
- Write time: 5.0 ms max.
- Noise suppression: Schmitt trigger and noise filter on input pins (SCL, SDA)
- Write protect function during the low power supply voltage
- Endurance: 10⁶cycles/word*¹ ($T_a = +25^\circ\text{C}$)
 3 × 10⁵cycles/word*¹ ($T_a = +85^\circ\text{C}$)
 2 × 10⁵cycles/word*¹ ($T_a = +105^\circ\text{C}$)
- Data retention: 100 years ($T_a = +25^\circ\text{C}$)
 30 years ($T_a = +85^\circ\text{C}$)
 25 years ($T_a = +105^\circ\text{C}$)
- Memory capacity: S-24C32C 32 K-bit
 S-24C64C 64 K-bit
- Write protect: 100%
- Initial delivery state: FFh
- Operation temperature range: $T_a = -40^\circ\text{C to }+105^\circ\text{C}$
- Lead-free (Sn 100%), halogen-free*²
- AEC-Q100 qualified*³

*1. For each address (Word: 8-bit)

*2. Refer to “■ Product Name Structure” for details.

*3. Contact our sales office for details.

■ Packages

- 8-Pin SOP (JEDEC)
- 8-Pin TSSOP

Caution Before using the product in medical equipment or automobile equipment including car audio, keyless entry and engine control unit, contact to SII Semiconductor Corporation is indispensable.

■ **Pin Configurations**

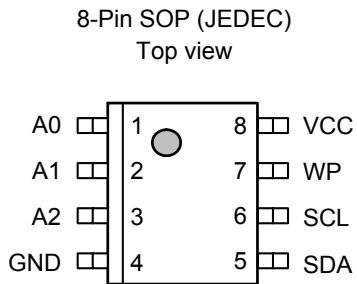

Figure 1

S-24C32CH-J8T2U3
S-24C64CH-J8T2U3

Table 1

Pin No	Symbol	Description
1	A0	Slave address input
2	A1	Slave address input
3	A2	Slave address input
4	GND	Ground
5	SDA*1	Serial data I/O
6	SCL*1	Serial clock input
7	WP	Write protect input Connected to V _{CC} : Protection valid Open or connected to GND: Protection invalid
8	VCC	Power supply

*1. Do not use it in high impedance.

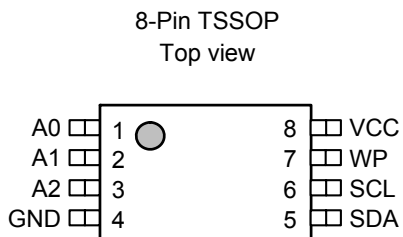

Figure 2

S-24C32CH-T8T2U3
S-24C64CH-T8T2U3

Table 2

Pin No	Symbol	Description
1	A0	Slave address input
2	A1	Slave address input
3	A2	Slave address input
4	GND	Ground
5	SDA*1	Serial data I/O
6	SCL*1	Serial clock input
7	WP	Write protect input Connected to V _{CC} : Protection valid Open or connected to GND: Protection invalid
8	VCC	Power supply

*1. Do not use it in high impedance.

Remark See Dimensions for details of the package drawings.

■ Block Diagram

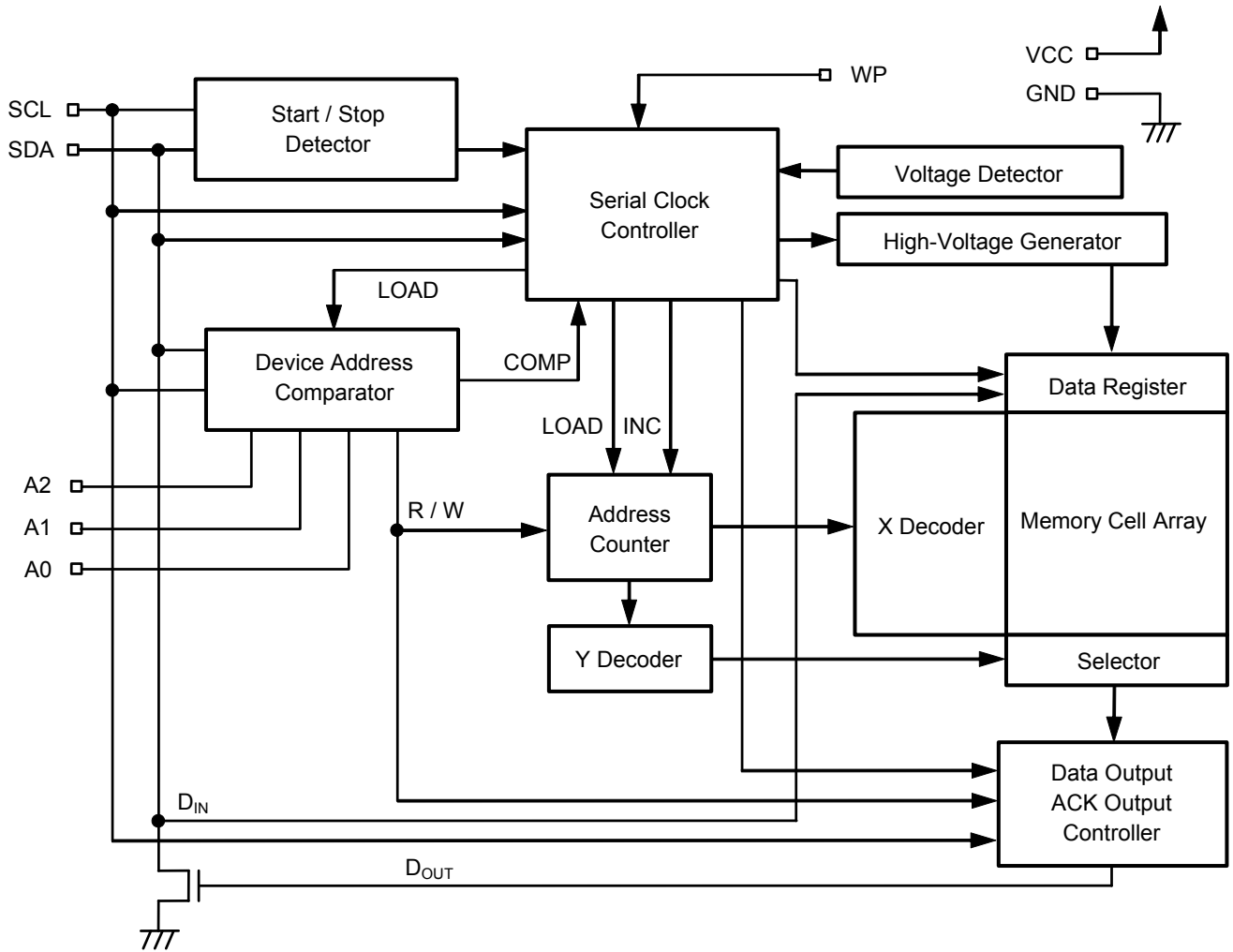

Figure 3

■ **AEC-Q100 Qualified**

This IC supports AEC-Q100 for operation temperature grade 2.
Contact our sales office for details of AEC-Q100 reliability specification.

■ **Absolute Maximum Ratings**

Table 3

Item	Symbol	Absolute Maximum Ratings	Unit
Power supply voltage	V _{CC}	-0.3 to +6.5	V
Input voltage	V _{IN}	-0.3 to +6.5	V
Output voltage	V _{OUT}	-0.3 to +6.5	V
Operation ambient temperature	T _{opr}	-40 to +105	°C
Storage temperature	T _{stg}	-65 to +150	°C

Caution The absolute maximum ratings are rated values exceeding which the product could suffer physical damage. These values must therefore not be exceeded under any conditions.

■ **Recommended Operating Conditions**

Table 4

Item	Symbol	Condition	Ta = -40°C to +105°C		Unit
			Min.	Max.	
Power supply voltage	V _{CC}	Read	2.5	5.5	V
		Write	2.5	5.5	V
High level input voltage	V _{IH}	V _{CC} = 2.5 V to 5.5 V	0.7 × V _{CC}	5.5	V
Low level input voltage	V _{IL}	V _{CC} = 2.5 V to 5.5 V	-0.3	0.3 × V _{CC}	V

■ **Pin Capacitance**

Table 5

(Ta = +25°C, f = 1.0 MHz, V_{CC} = 5.0 V)

Item	Symbol	Condition	Min.	Max.	Unit
Input capacitance	C _{IN}	V _{IN} = 0 V (SCL, A0, A1, A2, WP)	–	10	pF
I/O capacitance	C _{I/O}	V _{I/O} = 0 V (SDA)	–	10	pF

■ **Endurance**

Table 6

Item	Symbol	Operation Ambient Temperature	Min.	Max.	Unit
Endurance	N _w	Ta = +25°C	10 ⁶	–	cycles / word*1
		Ta = -40°C to +85°C	3 × 10 ⁵	–	cycles / word*1
		Ta = -40°C to +105°C	2 × 10 ⁵	–	cycles / word*1

*1. For each address (Word: 8 bits)

■ **Data Retention**

Table 7

Item	Symbol	Operation Ambient Temperature	Min.	Max.	Unit
Data retention	–	Ta = +25°C	100	–	year
		Ta = -40°C to +85°C	30	–	year
		Ta = -40°C to +105°C	25	–	year

■ DC Electrical Characteristics

Table 8

Item	Symbol	Condition	Ta = -40°C to +105°C		Unit
			V _{CC} = 2.5 V to 5.5 V f _{SCL} = 400 kHz		
			Min.	Max.	
Current consumption (READ)	I _{CC1}	–	–	0.8	mA

Table 9

Item	Symbol	Condition	Ta = -40°C to +105°C		Unit
			V _{CC} = 2.5 V to 5.5 V f _{SCL} = 400 kHz		
			Min.	Max.	
Current consumption (WRITE)	I _{CC2}	–	–	4.0	mA

Table 10

Item	Symbol	Condition	Ta = -40°C to +105°C		Unit
			V _{CC} = 2.5 V to 5.5 V		
			Min.	Max.	
Standby current consumption	I _{SB}	V _{IN} = V _{CC} or GND	–	12.0	μA
Input leakage current 1	I _{LI1}	SCL, SDA, V _{IN} = GND to V _{CC}	–	1.2	μA
Input leakage current 2	I _{LI2}	A0, A1, A2 V _{IN} > 0.7 × V _{CC} At standby mode	–	1.2	μA
Output leakage current	I _{LO}	SDA V _{OUT} = GND to V _{CC}	–	1.2	μA
Input current 1	I _{IL}	WP V _{IN} < 0.3 × V _{CC}	–	50.0	μA
Input current 2	I _{IH}	WP V _{IN} > 0.7 × V _{CC}	–	2.0	μA
Input Impedance 1	Z _{IL}	WP V _{IN} = 0.3 × V _{CC}	30	–	kΩ
Input Impedance 2	Z _{IH}	WP V _{IN} = 0.7 × V _{CC}	500	–	kΩ
Low level output voltage	V _{OL}	I _{OL} = 3.2 mA	–	0.4	V
		I _{OL} = 1.5 mA	–	0.3	V
		I _{OL} = 0.7 mA	–	0.2	V

■ AC Electrical Characteristics

Table 11 Measurement Conditions

Input pulse voltage	$0.2 \times V_{CC}$ to $0.8 \times V_{CC}$
Input pulse rising / falling time	20 ns or less
Output reference voltage	$0.3 \times V_{CC}$ to $0.7 \times V_{CC}$
Output load	100 pF

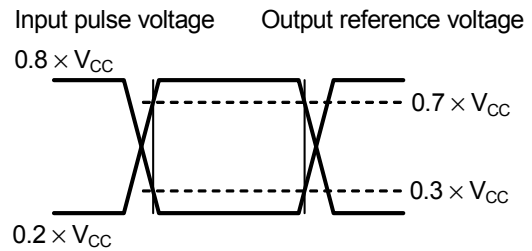

Figure 4 I/O Waveform during AC Measurement

Table 12

Item	Symbol	Ta = -40°C to +105°C		Unit
		VCC = 2.5 V to 5.5 V		
		Min.	Max.	
SCL clock frequency	f _{SCL}	0	400	kHz
SCL clock time "L"	t _{LOW}	1.3	–	μs
SCL clock time "H"	t _{HIGH}	0.6	–	μs
SDA output delay time	t _{AA}	0.1	0.9	μs
SDA output hold time	t _{DH}	50	–	ns
Start condition setup time	t _{SU.STA}	0.6	–	μs
Start condition hold time	t _{HD.STA}	0.6	–	μs
Data input setup time	t _{SU.DAT}	100	–	ns
Data input hold time	t _{HD.DAT}	0	–	ns
Stop condition setup time	t _{SU.STO}	0.6	–	μs
SCL, SDA rising time	t _R	–	0.3	μs
SCL, SDA falling time	t _F	–	0.3	μs
WP setup time	t _{WS1}	0	–	μs
WP hold time	t _{WH1}	0	–	μs
WP release setup time	t _{WS2}	0	–	μs
WP release hold time	t _{WH2}	0	–	μs
Bus release time	t _{BUF}	1.3	–	μs
Noise suppression time	t _i	–	50	ns

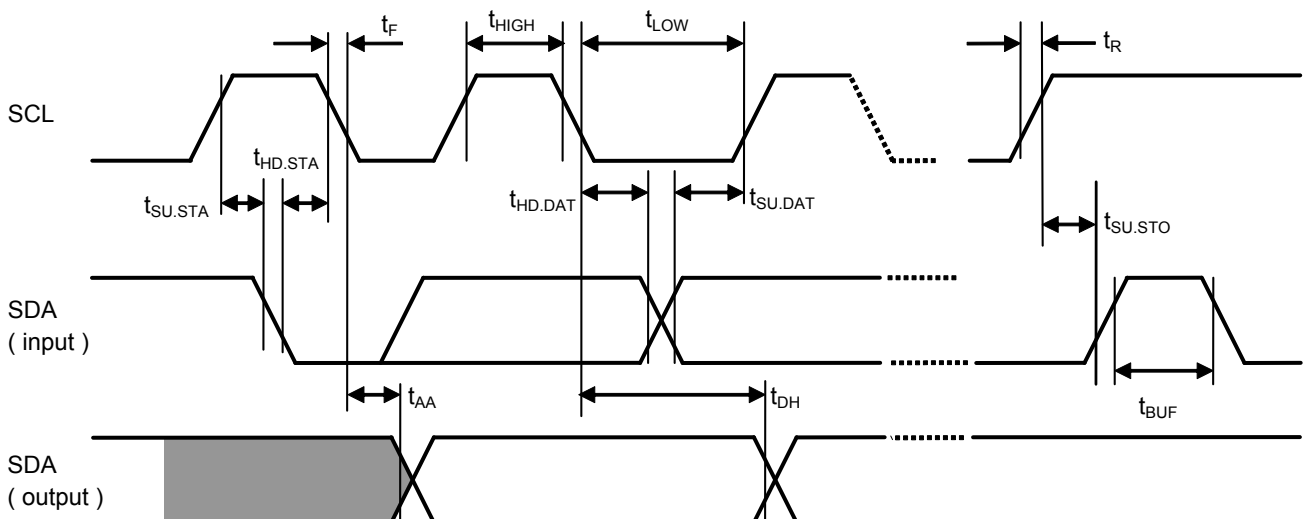

Figure 5 Bus Timing

Table 13

Item	Symbol	Ta = -40°C to +105°C		Unit
		Vcc = 2.5 V to 5.5 V		
		Min.	Max.	
Write time	t _{WR}	-	5.0	ms

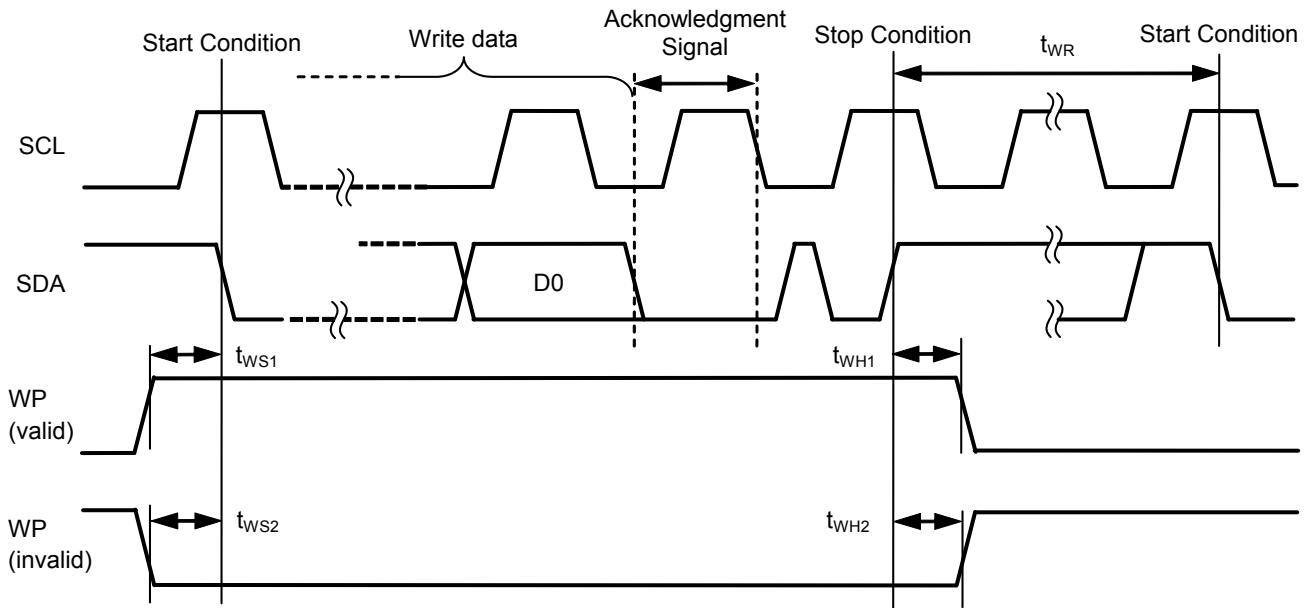

Figure 6 Write Cycle Timing

■ **Pin Functions**

1. A0, A1 and A2 (Slave address input) pins

In the S-24C32C/64C, to set the slave address, connect each pin of A0, A1, A2 to GND or V_{CC}. Therefore the users can set 8 types of slave address by a combination of A0, A1, A2 pins.

Comparing the slave address transmitted from the master device and one that you set, makes possible to select the S-24C32C/64C from other devices connected onto the bus.

Each A0, A1 and A2 pin has a pull-down resistor. In open, these pins have the status when they are connected to GND.

2. SDA (Serial data input / output) pin

The SDA pin is used for the bi-directional transmission of serial data. This pin is a signal input pin, and an Nch open drain output pin.

In use, generally, connect the SDA line to any other device which has the open-drain or open-collector output with Wired-OR connection by pulling up to V_{CC} by a resistor (**Figure 7** shows the relation with an output load).

3. SCL (Serial clock input) pin

The SCL pin is used for the serial clock input. Since the signals are processed at a rising or falling edge of the SCL clock, pay attention to the rising and falling time and comply with the specification.

4. WP (Write protect input) pin

The write protect is enabled by connecting the WP pin to V_{CC}. When not using the write protect, connect this pin to GND or set in open.

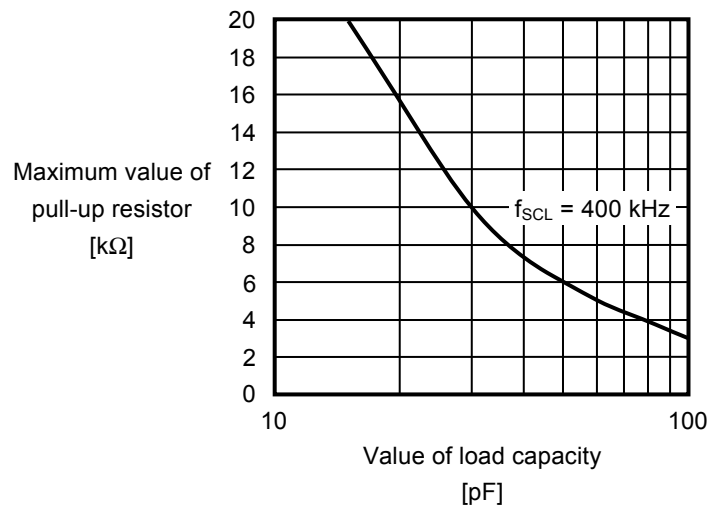

Figure 7 Output Load

■ **Initial Delivery State**

Initial delivery state of all addresses is "FFh".

■ **Operation**

1. Start condition

Start is identified by a high to low transition of the SDA line while the SCL line is stable at high. Every operation begins from a start condition.

2. Stop condition

Stop is identified by a low to high transition of the SDA line while the SCL line is stable at high. When a device receives a stop condition during a read sequence, the read operation is interrupted, and the device enters standby mode. When a device receives a stop condition during a write sequence, the reception of the write data is halted, and the S-24C32C/64C initiates a write cycle.

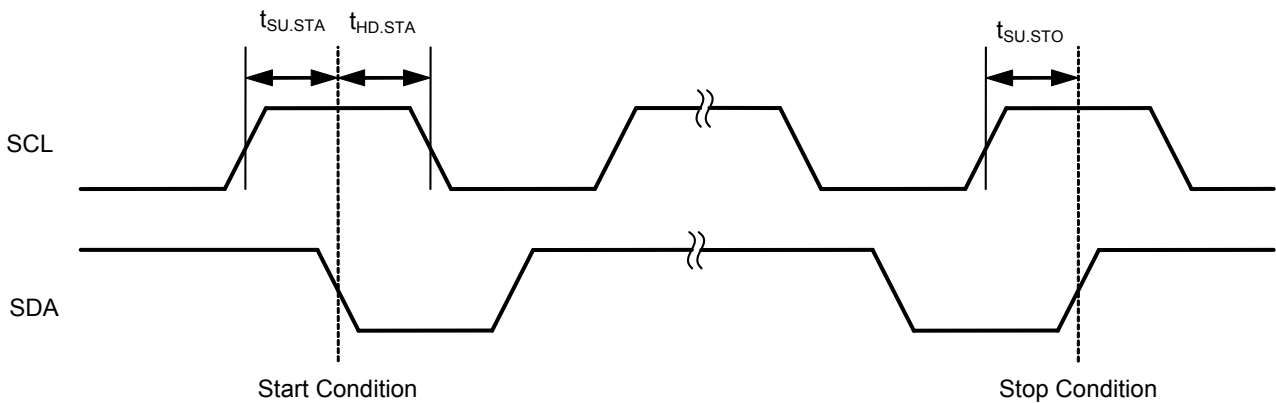

Figure 8 Start / Stop Conditions

3. Data transmission

Changing the SDA line while the SCL line is low, data is transmitted.
Changing the SDA line while the SCL line is high, a start or stop condition is recognized.

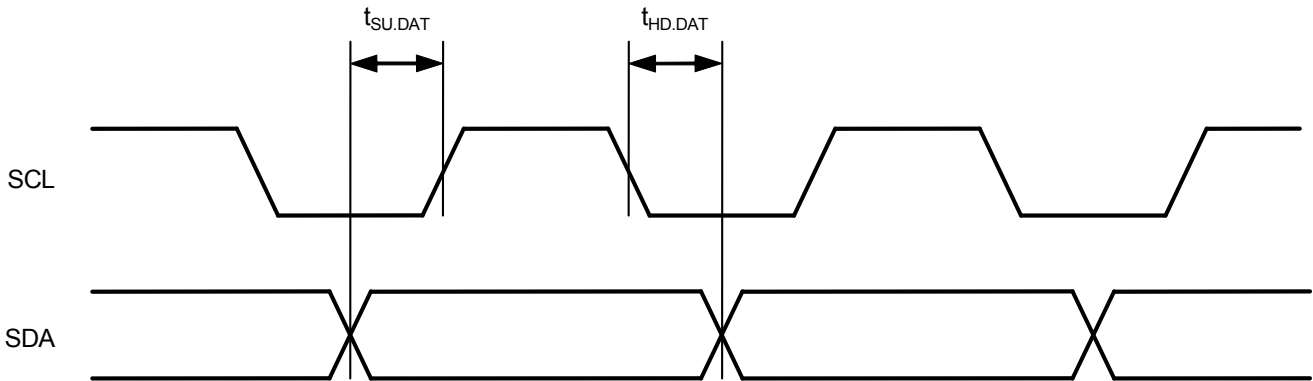

Figure 9 Data Transmission Timing

4. Acknowledge

The unit of data transmission is 8 bits. During the 9th clock cycle period the receiver on the bus pulls down the SDA line to acknowledge the receipt of the 8-bit data.

When an internal write cycle is in progress, the device does not generate an acknowledge.

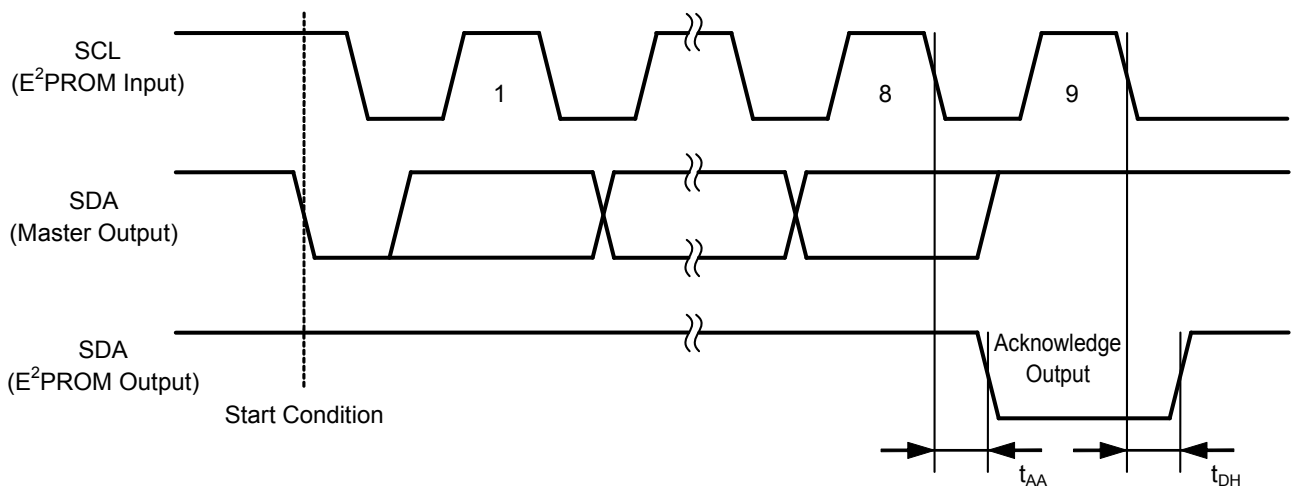

Figure 10 Acknowledge Output Timing

5. Device addressing

To start communication, the master device on the system generates a start condition to the bus line. Next, the master device sends 7-bit device address and a 1-bit read / write instruction code on to the SDA bus. The upper 4 bits of the device address are the “Device Code”, and are fixed to “1010”.

In the S-24C32C/64C, successive 3 bits are the “Slave Address”. These 3 bits are used to identify a device on the system bus and is compared with the predetermined value which is defined by the address input pins (A2, A1, A0). When the comparison result matches, the slave device responds with an acknowledge during the 9th clocks cycle.

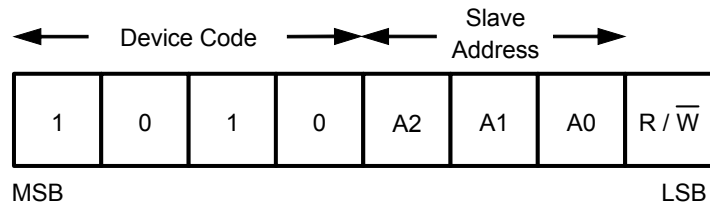

Figure 11 Device Address

6. Write

6.1 Byte write

When the master sends a 7-bit device address and a 1-bit read / write instruction code set to “0”, following a start condition, the S-24C32C/64C acknowledges it. The S-24C32C/64C then receives an upper 8-bit word address and responds with an acknowledge. And the S-24C32C/64C receives a lower 8-bit word address and responds with an acknowledge. After the S-24C32C/64C receives 8-bit write data and responds with an acknowledge, it receives a stop condition and that initiates the write cycle at the addressed memory.

During the write cycle all operations are forbidden and no acknowledge is generated.

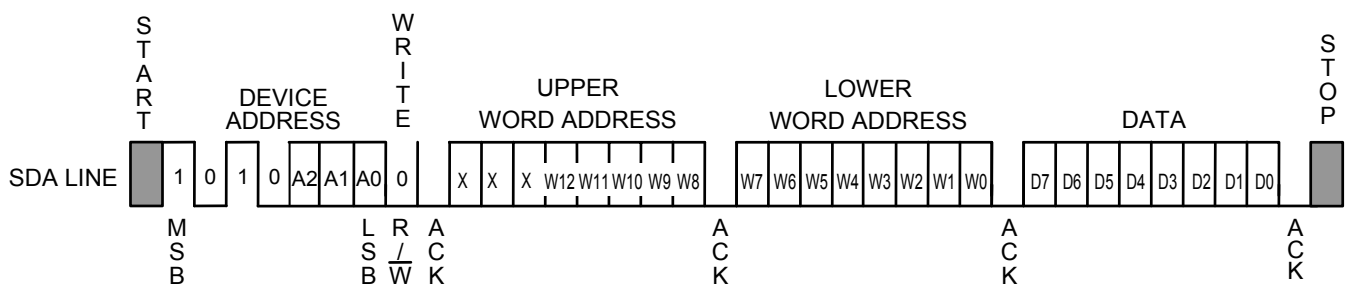

Remark W12 is arbitrary in the S-24C32C.

Figure 12 Byte Write

6.2 Page write

The page write mode allows up to 32 bytes to be written in a single write operation in the S-24C32C/64C. Its basic process to transmit data is as same as byte write, but it operates page write by sequentially receiving 8-bit write data as much data as the page size has.

When the S-24C32C/64C receives a 7-bit device address and a 1-bit read / write instruction code set to “0”, following a start condition, it generates an acknowledge. And the S-24C32C/64C receives a upper 8-bit word address, and responds with an acknowledge. Then the S-24C32C/64C receives a lower 8-bit word address, and responds with an acknowledge. After the S-24C32C/64C receives 8-bit write data and responds with an acknowledge, it receives 8-bit write data corresponding to the next word address, and generates an acknowledge. The S-24C32C/64C repeats reception of 8-bit write data and generation of acknowledge in succession. The S-24C32C/64C can receive as many write data as the maximum page size.

Receiving a stop condition initiates a write cycle of the area starting from the designated memory address and having the page size equal to the received write data.

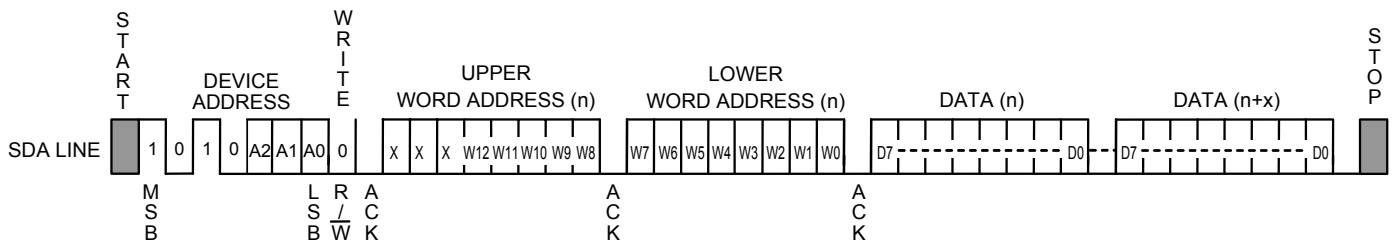

Remark W12 is arbitrary in the S-24C32C.

Figure 13 Page Write

In the S-24C32C, the lower 5 bits of the word address are automatically incremented every time when the S-24C32C/64C receives 8-bit write data. If the size of the write data exceeds 32 bytes, the upper 7 bits of the word address remain unchanged, and the lower 5 bits are rolled over and the last 32-byte data that the S-24C32C received will be overwritten.

In the S-24C64C, the lower 5 bits of the word address are automatically incremented every time when the S-24C32C/64C receives 8-bit write data. If the size of the write data exceeds 32 bytes, the upper 8 bits of the word address remain unchanged, and the lower 5 bits are rolled over and the last 32-byte data that the S-24C64C received will be overwritten.

6.3 Write protect

Write protect is available in the S-24C32C/64C. When the WP pin is connected to the V_{CC}, write operation to memory area is inhibited.

When the WP pin is connected to GND or set in open, the write protect is invalid, and write operation in all memory area is available.

Fix the level of the WP pin from start condition in the write operation (byte write, page write) until stop condition. If the WP pin changes during this time, the address data being written at this time is not guaranteed. Regarding the timing of write protect, refer to **Figure 6**.

In not using the write protect, connect the WP pin to GND or set it open. The write protect is valid in the range of operation power supply voltage.

As seen in **Figure 14** when the write protect is valid, the S-24C32C/64C does not generate an acknowledgment signal after data input.

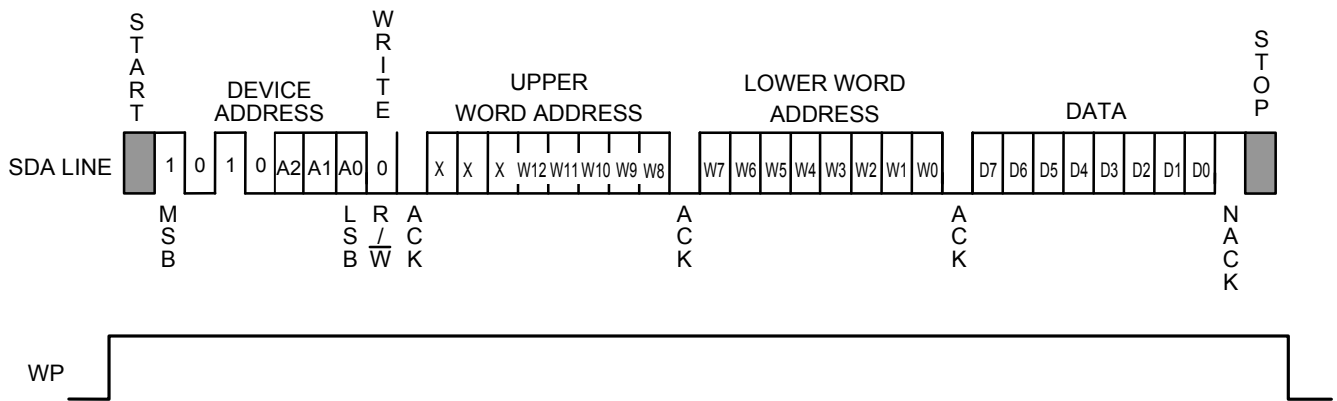

Remark W12 is arbitrary in the S-24C32C.

Figure 14 Write Protect

6.4 Acknowledge polling

Acknowledge polling is used to know the completion of the write cycle in the S-24C32C/64C.

After the S-24C32C/64C receives a stop condition and once starts the write cycle, all operations are inhibited and no response is made to the signal transmitted by the master device.

Accordingly the master device can recognize the completion of the write cycle in the S-24C32C/64C by detecting a response from the slave device after transmitting the start condition, the device address and the read / write instruction code to the S-24C32C/64C (slave device).

That is, if the S-24C32C/64C does not generate an acknowledgment signal, the write cycle is in progress and if the S-24C32C/64C generates an acknowledgment signal, the write cycle has been completed.

It is recommended to use the read instruction “1” as the read / write instruction code transmitted by the master device.

Acknowledge polling during write

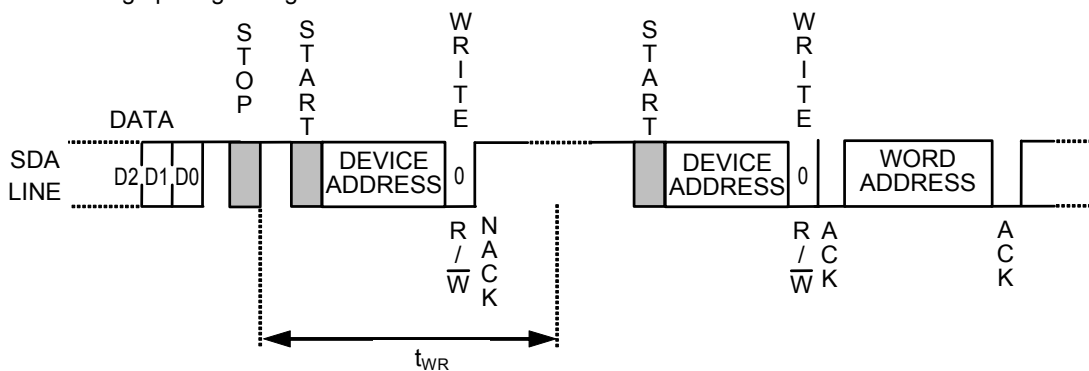

Acknowledge polling during read

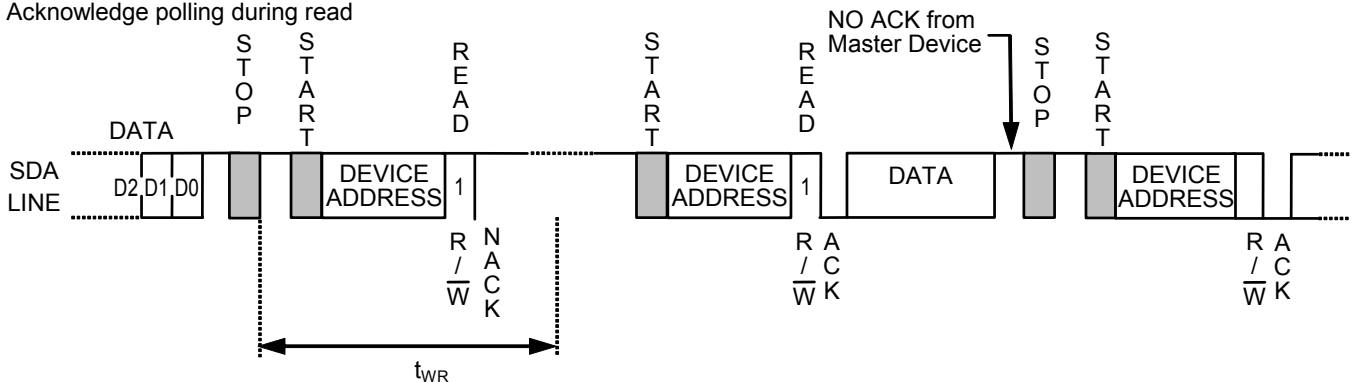

Remark Users are able to input word address and data after ACK output in acknowledge polling during write. Users are able to read data after ACK output in acknowledge polling during read. However, after that users input the write instruction, a start condition may not be input during data output. Input a stop condition and the next instruction after data output and ACK output.

Figure 15 Usage Example of Acknowledge Polling

7. Read

7.1 Current address read

Either in writing or in reading the S-24C32C/64C holds the last accessed memory address. The memory address is maintained as long as the power voltage does not decrease less than the operating voltage.

The master device can read the data at the memory address of the current address pointer without assigning the word address as a result, when it recognizes the position of the address pointer in the S-24C32C/64C. This is called "Current Address Read".

In the following the address counter in the S-24C32C/64C is assumed to be "n".

When the S-24C32C/64C receives a 7-bit device address and a 1-bit read / write instruction code set to "1" following a start condition, it responds with an acknowledge.

Next, an 8-bit data at the address "n" is sent from the S-24C32C/64C synchronous to the SCL clock. The address counter is incremented and the content of the address counter becomes n+1.

The master device outputs stop condition not an acknowledge, the reading of S-24C32C/64C is ended.

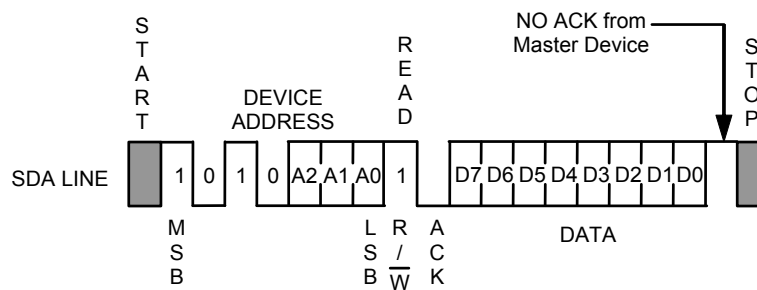

Figure 16 Current Address Read

Attention should be paid to the following point on the recognition of the address pointer in the S-24C32C/64C. In Read, the memory address counter in the S-24C32C/64C is automatically incremented after output of the 8th bit of the data. In Write, on the other hand, the upper bits of the memory address (the upper bits of the word address*1) are left unchanged and are not incremented.

*1. In the S-24C32C, the upper 7 bits of the word address.
In the S-24C64C, the upper 8 bits of the word address.

7.2 Random read

Random read is used to read the data at an arbitrary memory address.

A dummy write is performed to load the memory address into the address counter.

When the S-24C32C/64C receives a 7-bit device address and a 1-bit read / write instruction code set to “0” following a start condition, it responds with an acknowledge.

The S-24C32C/64C then receives an upper 8-bit word address and responds with an acknowledge. And the S-24C32C/64C receives a lower 8-bit word address and responds with an acknowledge. The memory address is loaded to the address counter in the S-24C32C/64C by these operations. Reception of write data does not follow in a dummy write whereas reception of write data follows in byte write and in page write.

Since the memory address is loaded into the memory address counter by dummy write, the master device can read the data starting from the arbitrary memory address by transmitting a new start condition and performing the same operation in the current address read.

That is, when the S-24C32C/64C receives a 7-bit device address and a 1-bit read / write instruction code set to “1”, following a start condition signal, it responds with an acknowledge. Next, 8-bit data is transmitted from the S-24C32C/64C in synchronous to the SCL clock. The master device outputs stop condition not an acknowledge, the reading of S-24C32C/64C is ended.

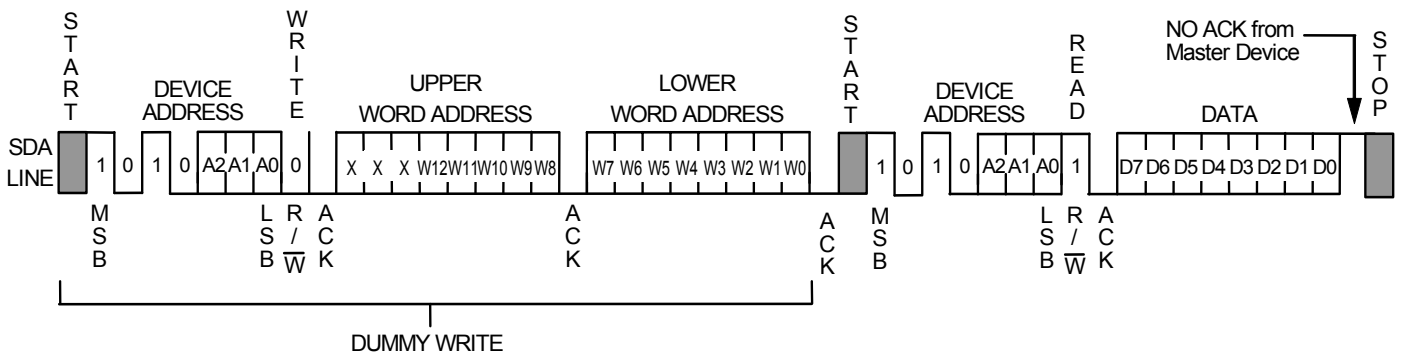

Remark W12 is arbitrary in the S-24C32C.

Figure 17 Random Read

7.3 Sequential read

When the S-24C32C/64C receives a 7-bit device address and a 1-bit read / write instruction code set to “1” following a start condition both in current address read and random read, it responds with an acknowledge.

When an 8-bit data is output from the S-24C32C/64C synchronous to the SCL clock, the address counter is automatically incremented.

When the master device responds with an acknowledge, the data at the next memory address is transmitted. Response with an acknowledge by the master device has the memory address counter in the S-24C32C/64C incremented and makes it possible to read data in succession. This is called “Sequential Read”.

The master device outputs stop condition not an acknowledge, the reading of S-24C32C/64C is ended.

Data can be read in succession in the sequential read mode. When the memory address counter reaches the last word address, it rolls over to the first word address.

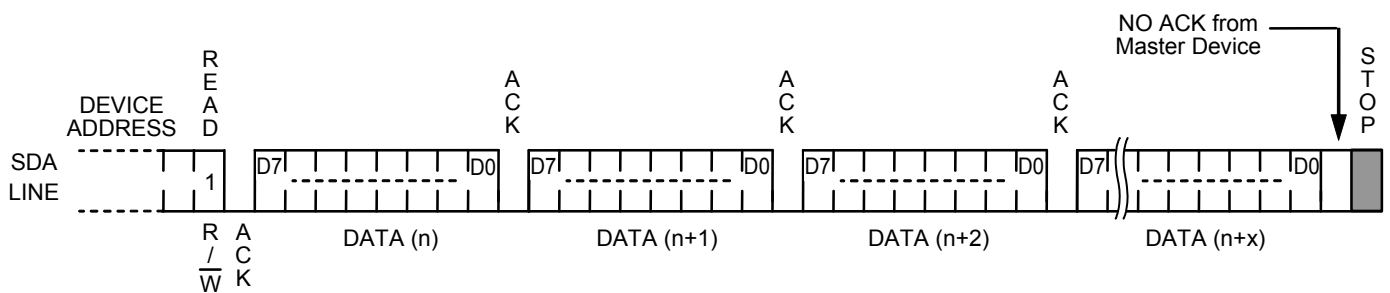

Figure 18 Sequential Read

■ **Write Protect Function during the Low Power Supply Voltage**

The S-24C32C/64C has a built-in detection circuit which operates with the low power supply voltage, cancels Write when the power supply voltage drops and power-on. Its detection and release voltages are 1.20 V typ. (Refer to **Figure 19**). The S-24C32C/64C cancels Write by detecting a low power supply voltage when it receives a stop condition. In the data transmission and the Write operation, data in the address written during the low power supply voltage is not assurable.

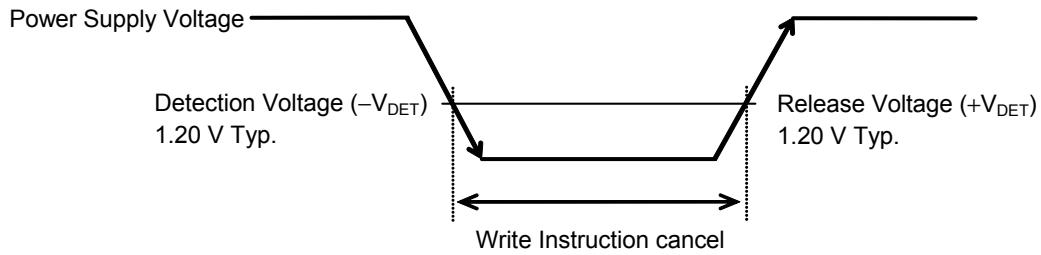

Figure 19 Operation during Low Power Supply Voltage

■ **Using S-24C32C/64C**

1. Adding a pull-up resistor to SDA I/O pin and SCL input pin

In consideration of I²C-bus protocol function, the SDA I/O pins should be connected with a pull-up resistor. The S-24C32C/64C cannot transmit normally without using a pull-up resistor.

In case that the SCL input pin of the S-24C32C/64C is connected to the Nch open drain output pin of the master device, connect the SCL pin with a pull-up resistor. As well, in case the SCL input pin of the S-24C32C/64C is connected to the tri-state output pin of the master device, connect the SCL pin with a pull-up resistor in order not to set it in high impedance. This prevents the S-24C32C/64C from error caused by an uncertain output (high impedance) from the tri-state pin when resetting the master device during the voltage drop.

2. Equivalent circuit of input and I/O pin

The S-24C32C/64C does not have a built-in pull-down or pull-up resistor for the SCL and SDA pins. The WP, A2, A1 and A0 pins have a pull-down resistor. The SDA pin has an open-drain output. The followings are equivalent circuits of the pins.

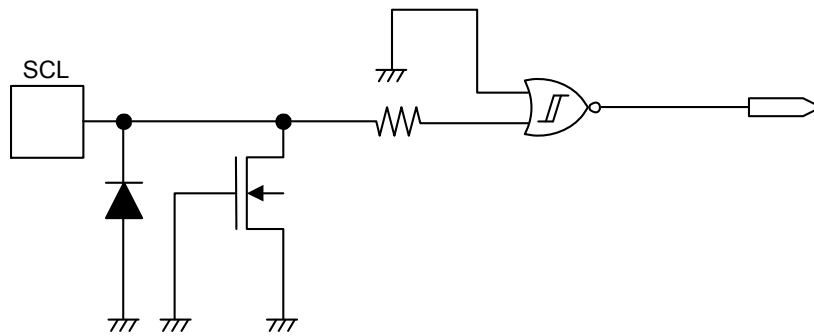

Figure 20 SCL Pin

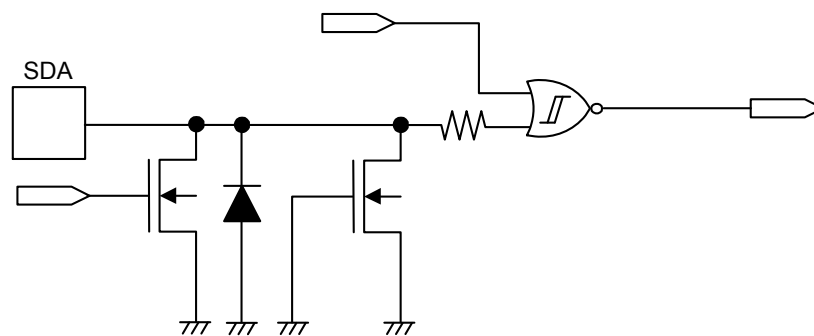

Figure 21 SDA Pin

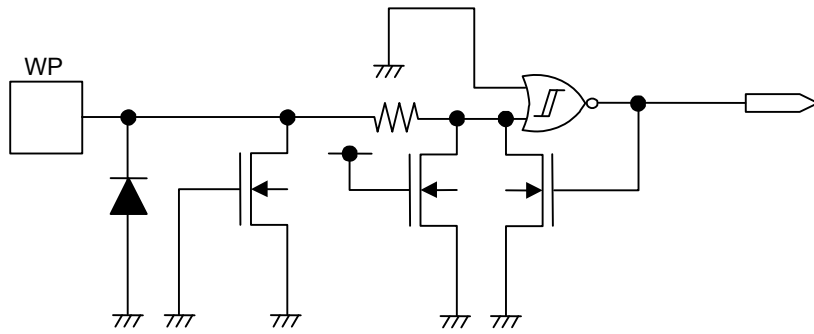

Figure 22 WP Pin

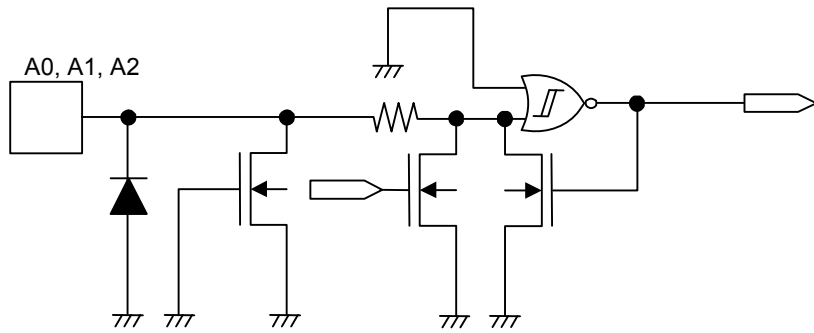

Figure 23 A0, A1, A2 Pins

3. Phase adjustment during S-24C32C/64C access

The S-24C32C/64C does not have a pin to reset (the internal circuit). The users cannot forcibly reset it externally. If the communication to the S-24C32C/64C interrupted, the users need to handle it as you do for software.

In the S-24C32C/64C, users are able to reset the internal circuit by inputting a start condition and a stop condition.

Although the reset signal is input to the master device, the S-24C32C/64C's internal circuit does not go in reset, but it does by inputting a stop condition to the S-24C32C/64C. The S-24C32C/64C keeps the same status thus cannot do the next operation. Especially, this case corresponds to that only the master device is reset when the power supply voltage drops.

If the power supply voltage restored in this status, input the instruction after resetting (adjusting the phase with the master device) the S-24C32C/64C. How to reset is shown below.

[How to reset S-24C32C/64C]

The S-24C32C/64C is able to be reset by a start and stop instructions. When the S-24C32C/64C is reading data "0" or is outputting the acknowledgment signal, outputs "0" to the SDA line. In this status, the master device cannot output an instruction to the SDA line. In this case, terminate the acknowledgment output operation or the Read operation, and then input a start instruction. **Figure 24** shows this procedure.

First, input a start condition. Then transmit 9 clocks (dummy clock) of SCL. During this time, the master device sets the SDA line to "H". By this operation, the S-24C32C/64C interrupts the acknowledgment output operation or data output, so input a start condition*1. When a start condition is input, the S-24C32C/64C is reset. To make doubly sure, input the stop condition to the S-24C32C/64C. The normal operation is then possible.

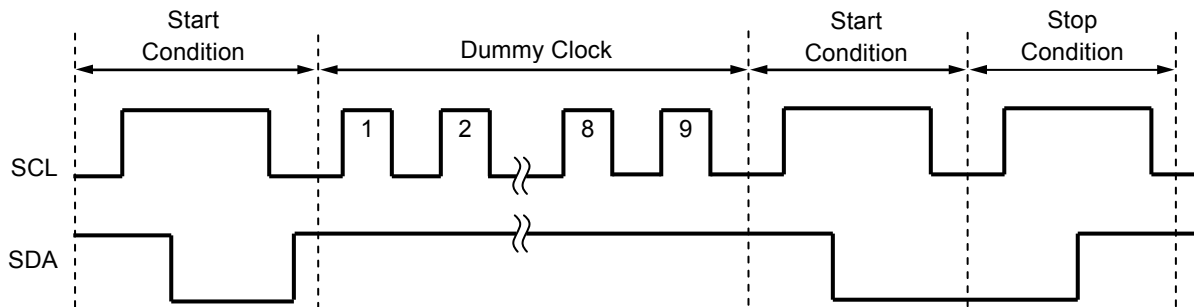

Figure 24 Resetting S-24C32C/64C

*1. After 9 clocks (dummy clock), if the SCL clock continues to being output without inputting a start condition, S-24C32C/64C may go in the write operation when it receives a stop condition. To prevent this, input a start condition after 9 clocks (dummy clock).

Remark Regarding this reset procedure with dummy clock, it is recommended to perform at the system initialization after applying the power supply voltage.

4. Acknowledge check

The I²C-bus protocol includes an acknowledge check function as a handshake function to prevent a communication error. This function allows detection of a communication failure during data communication between the master device and S-24C32C/64C. This function is effective to prevent malfunction, so it is recommended to perform an acknowledge check with the master device.

5. Built-in power-on-clear circuit

The S-24C32C/64C has a built-in power-on-clear circuit that initializes itself at the same time during power-on. Unsuccessful initialization may cause a malfunction. To operate the power-on-clear circuit normally, the following conditions must be satisfied to raise the power supply voltage.

5.1 Raising power supply voltage

Shown in **Figure 25**, raise the power supply voltage from 0.2 V max., within the time defined as t_{RISE} which is the time required to reach the power supply voltage to be set.

For example, if the power supply voltage is 5.0 V, $t_{RISE} = 200$ ms seen in **Figure 26**. The power supply voltage must be raised within 200 ms.

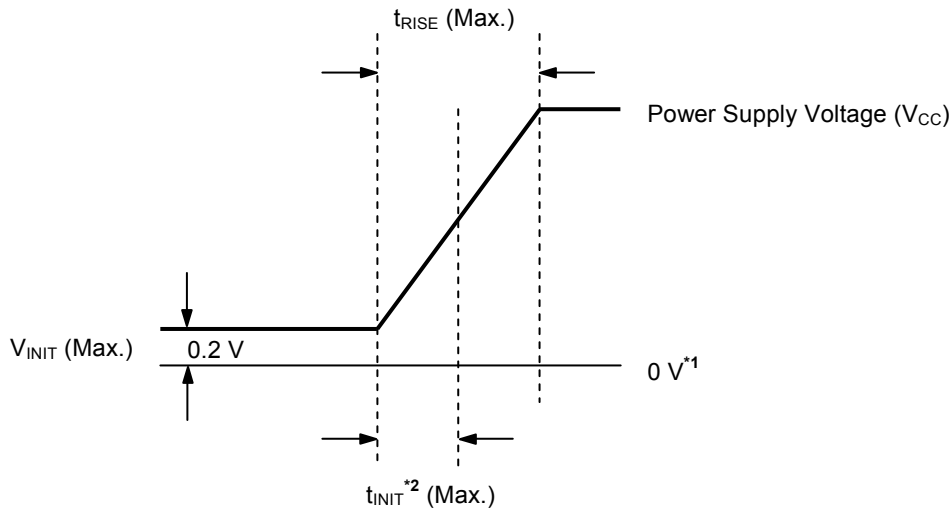

*1. 0 V means there is no difference in potential between the VCC pin and the GND pin of the S-24C32C/64C.

*2. t_{INIT} is the time required to initialize the S-24C32C/64C. No instructions are accepted during this time.

Figure 25 Raising Power Supply Voltage

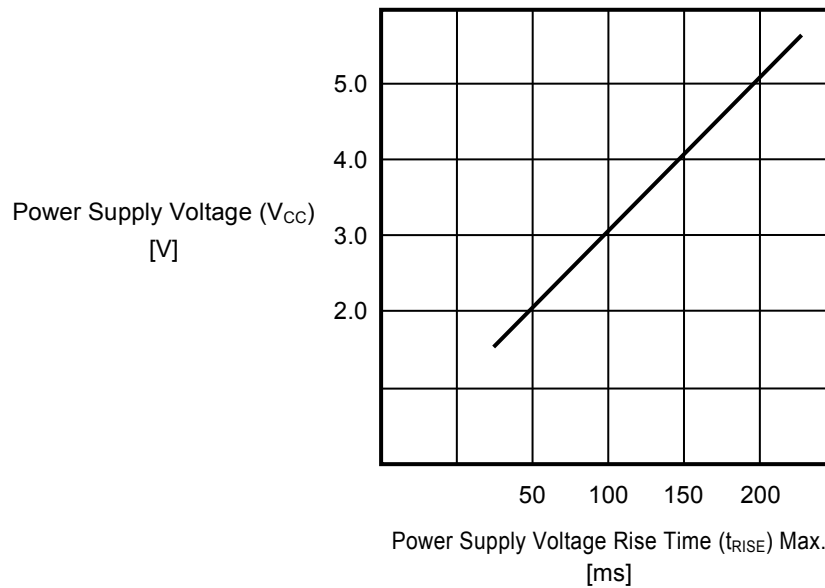

For example: If the supply voltage = 5.0 V, raise the power supply voltage to 5.0 V within 200 ms.

Figure 26 Power Supply Voltage Rise Time

When initialization is successfully completed by the power-on-clear circuit, the S-24C32C/64C enters the standby status.

If the power-on-clear circuit does not operate;

The S-24C32C/64C has not completed initialization, an instruction previously input is still valid or an instruction may be inappropriately recognized. In this case, S-24C32C/64C may perform the Write operation.

The voltage drops due to power off while the S-24C32C/64C is being accessed. Even if the master device is reset due to the low power voltage, the S-24C32C/64C may malfunction unless the power-on-clear operation conditions of S-24C32C/64C are satisfied.

When not keeping to the power supply voltage rise time seen in **Figure 26**, adjust the phase (reset) to reset the internal circuit in the S-24C32C/64C normally.

5.2 Initialization time

The S-24C32C/64C initializes at the same time when the power supply voltage is raised. Input instructions to the S-24C32C/64C after initialization. S-24C32C/64C does not accept any instruction during initialization.

Figure 27 shows the initialization time of the S-24C32C/64C.

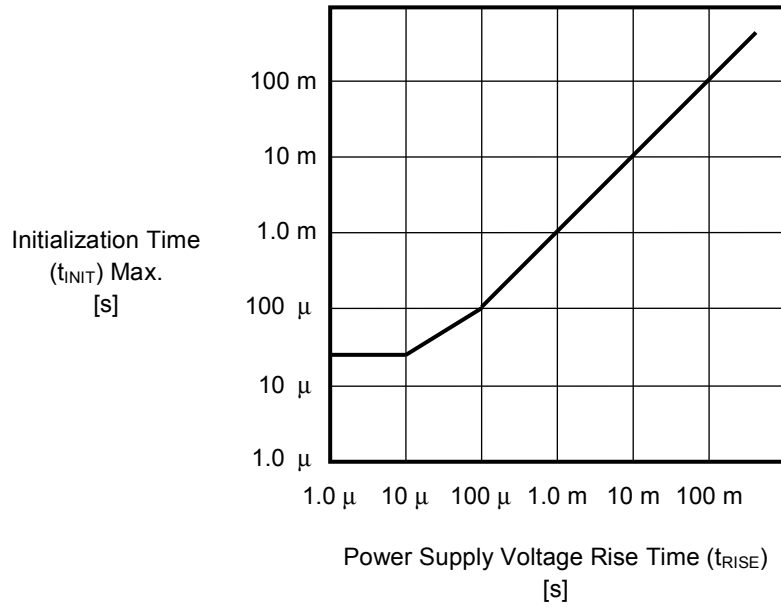

Figure 27 Initialization Time of S-24C32C/64C

6. Data hold time ($t_{HD,DAT} = 0 \text{ ns}$)

If SCL and SDA of the S-24C32C/64C are changed at the same time, it is necessary to prevent a start / stop condition from being mistakenly recognized due to the effect of noise.

The S-24C32C/64C may error if it does not recognize a start / stop condition correctly during transmission.

It is recommended to set the delay time of 0.3 μs minimum from a falling edge of SCL for the SDA.

This is to prevent S-24C32C/64C from going in a start / stop condition due to the time lag caused by the load of the bus line.

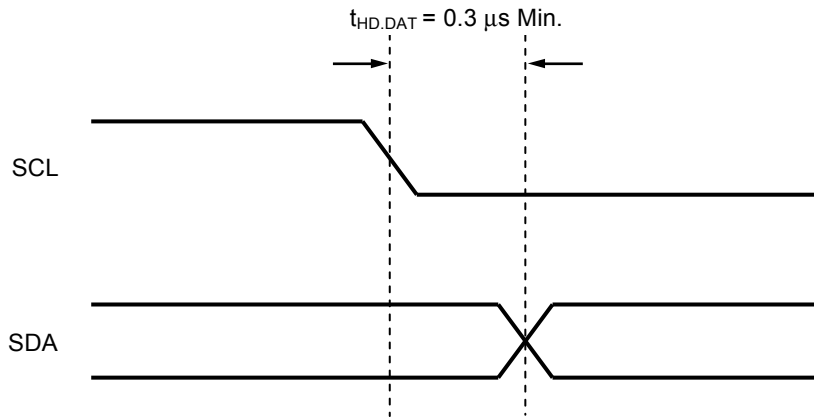

Figure 28 S-24C32C/64C Data Hold Time

7. SDA pin and SCL pin noise suppression time

The S-24C32C/64C includes a built-in low-pass filter at the SDA and SCL pins to suppress noise. If the power supply voltage is 5.0 V, noise with a pulse width of 130 ns or less can be suppressed.

For details of the assurable value, refer to noise suppression time (t_i) in **Table 12**.

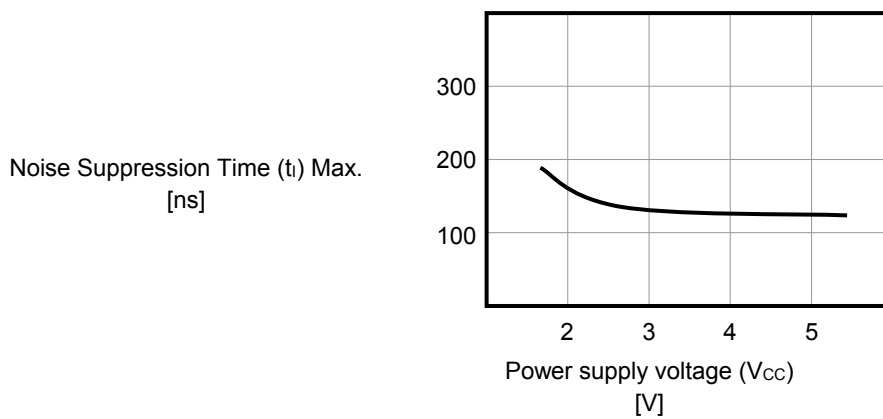
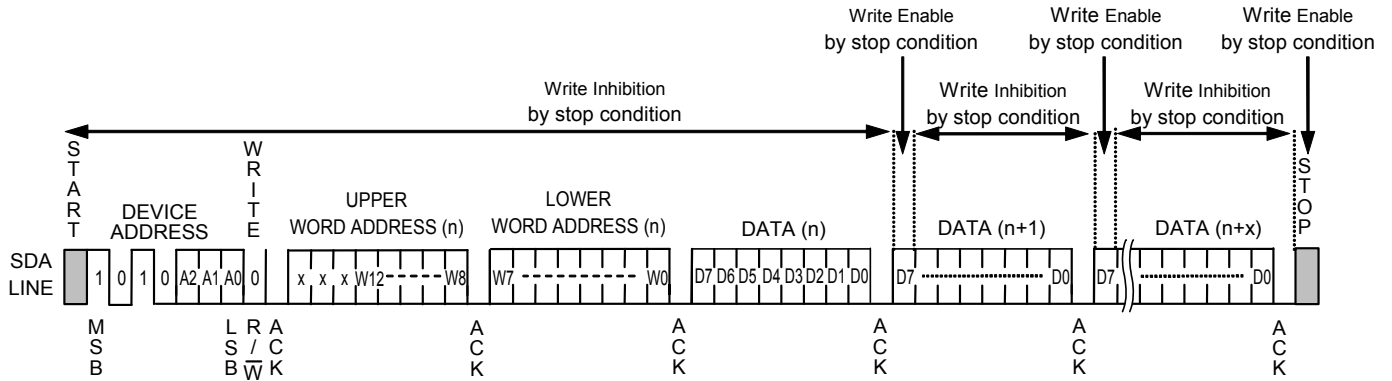

Figure 29 Noise Suppression Time for SDA and SCL Pins

8. Operation when input stop condition during input write data

The S-24C32C/64C does the write operation only when it receives data of 1 byte or more and receives a stop condition immediately after ACK output. Refer to **Figure 30** regarding details.



Remark W12 is arbitrary in the S-24C32C.

Figure 30 Write Operation by Inputting Stop Condition during Write

9. Command cancel by start condition

By a start condition, users are able to cancel command which is being input. However, adjust the phase while the S-24C32C/64C is outputting “L” because users are not able to input a start condition. When users cancel the command, there may be a case that the address will not be identified. Use random read for the read operation, not current address read.

10. Precaution for use

Do not operate these ICs in excess of the absolute maximum ratings. Attention should be paid to the power supply voltage, especially. The surge voltage which exceeds the maximum absolute ratings can cause latch-up and malfunction. Perform operations after confirming the detailed operation condition in the data sheet.

Operations with moisture on the S-24C32C/64C pins may occur malfunction by short-circuit between pins. Especially, in occasions like picking the S-24C32C/64C up from low temperature tank during the evaluation. Be sure that not remain frost on the S-24C32C/64C’s pins to prevent malfunction by short-circuit.

Also attention should be paid in using on environment, which is easy to dew for the same reason.

■ **Precaution**

- Do not apply an electrostatic discharge to this IC that exceeds the performance ratings of the built-in electrostatic protection circuit.
- SII Semiconductor Corporation claims no responsibility for any and all disputes arising out of or in connection with any infringement of the products including this IC upon patents owned by a third party.

■ **Product Name Structure**

1. **Product name**

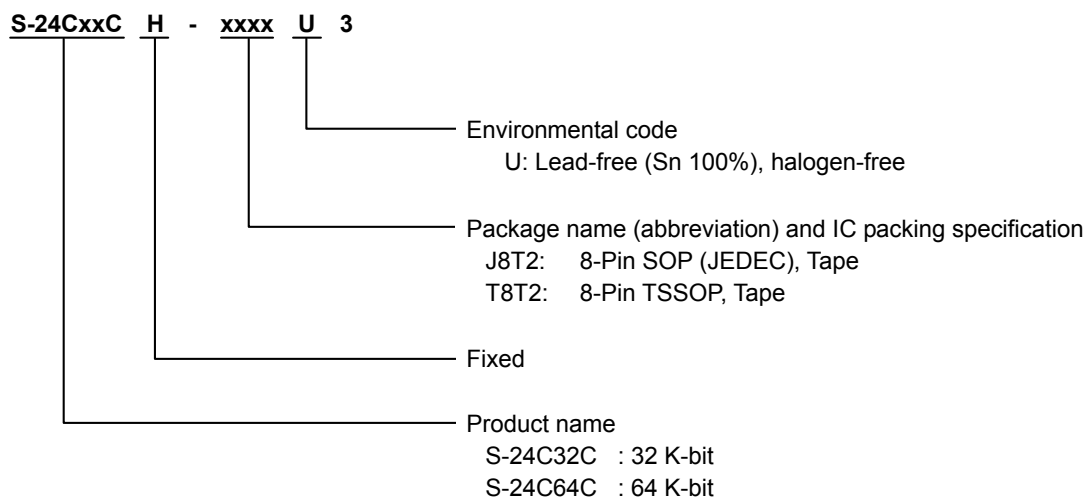

Remark Please contact our sales office for products with product name structure other than those specified above.

2. **Package**

Package name	Drawing code		
	Package	Tape	Reel
8-Pin SOP (JEDEC)	FJ008-A-P-SD	FJ008-D-C-SD	FJ008-D-R-S1
8-Pin TSSOP	FT008-A-P-SD	FT008-E-C-SD	FT008-E-R-S1

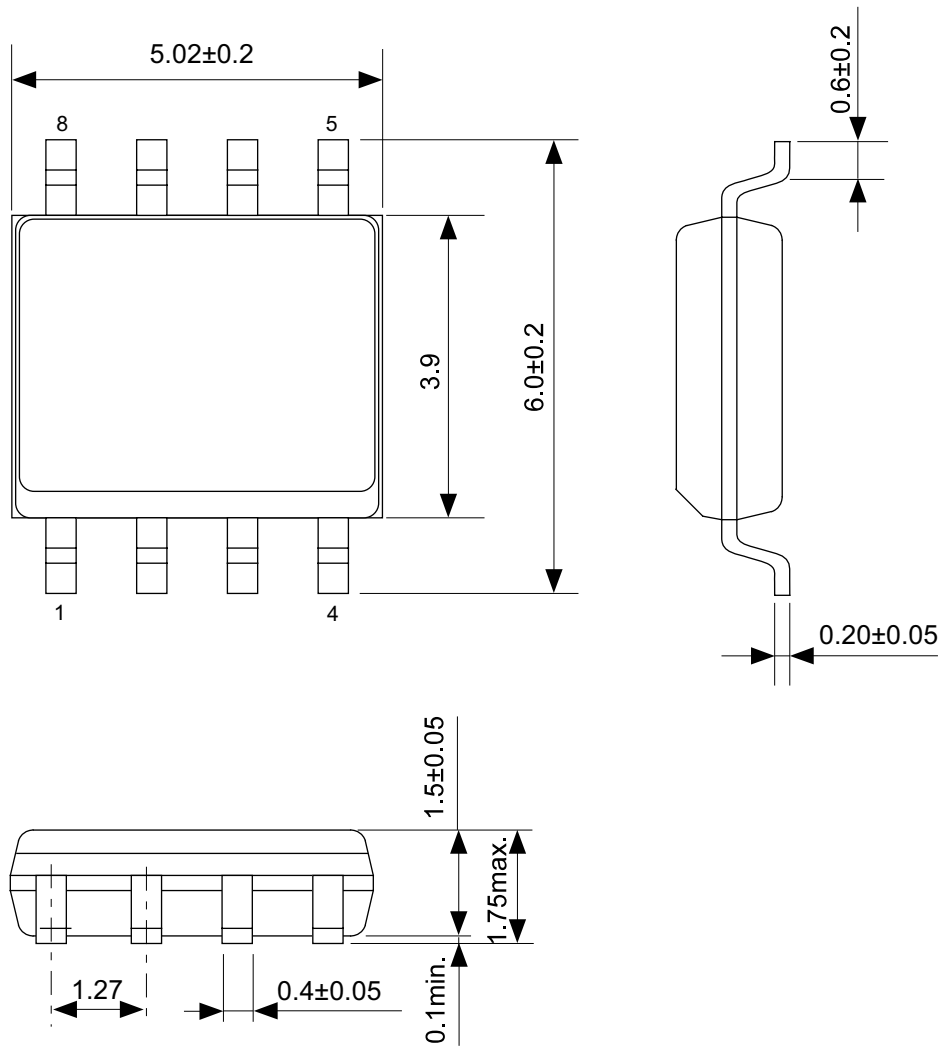

No. FJ008-A-P-SD-2.1

TITLE	SOP8J-D-PKG Dimensions
No.	FJ008-A-P-SD-2.1
SCALE	
UNIT	mm
SII Semiconductor Corporation	

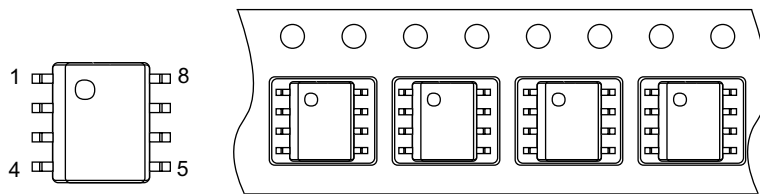
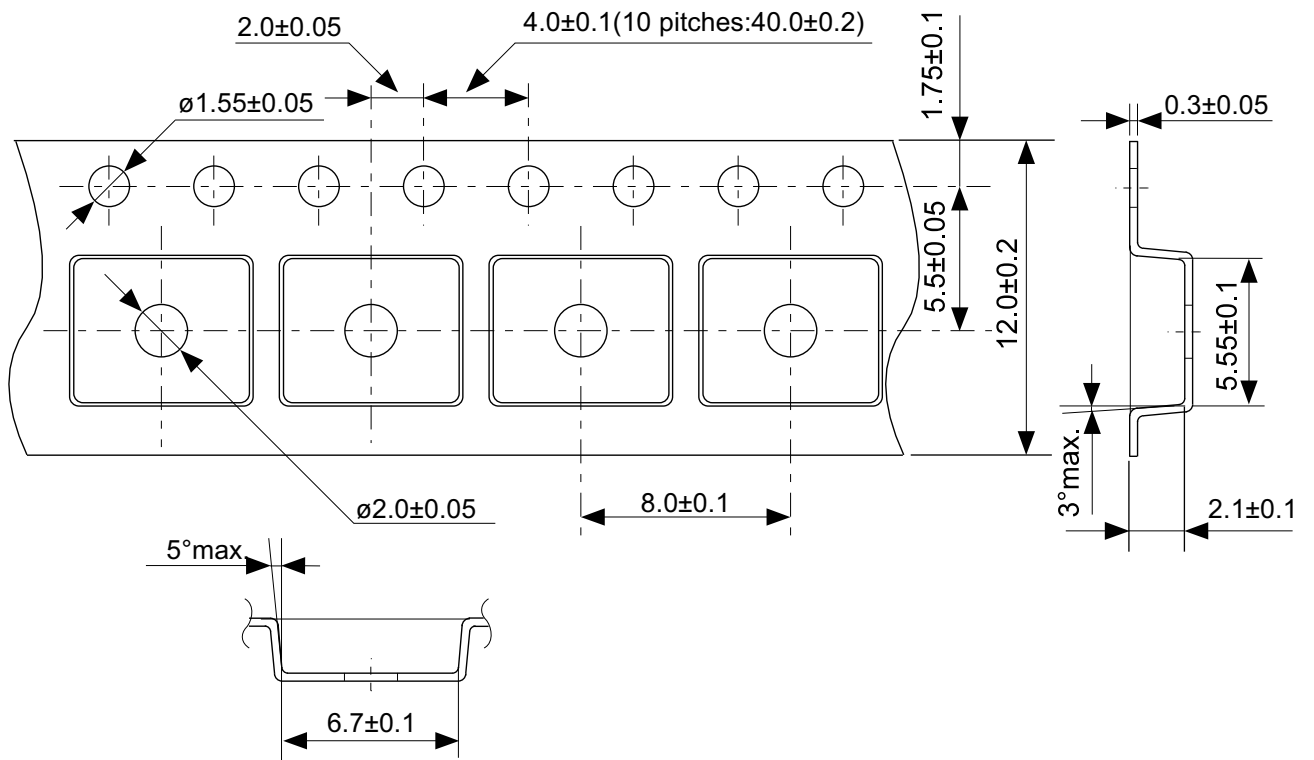

→ Feed direction

No. FJ008-D-C-SD-1.1

TITLE	SOP8J-D-Carrier Tape
No.	FJ008-D-C-SD-1.1
SCALE	
UNIT	mm
SII Semiconductor Corporation	

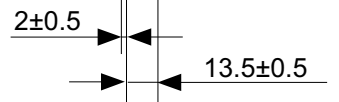
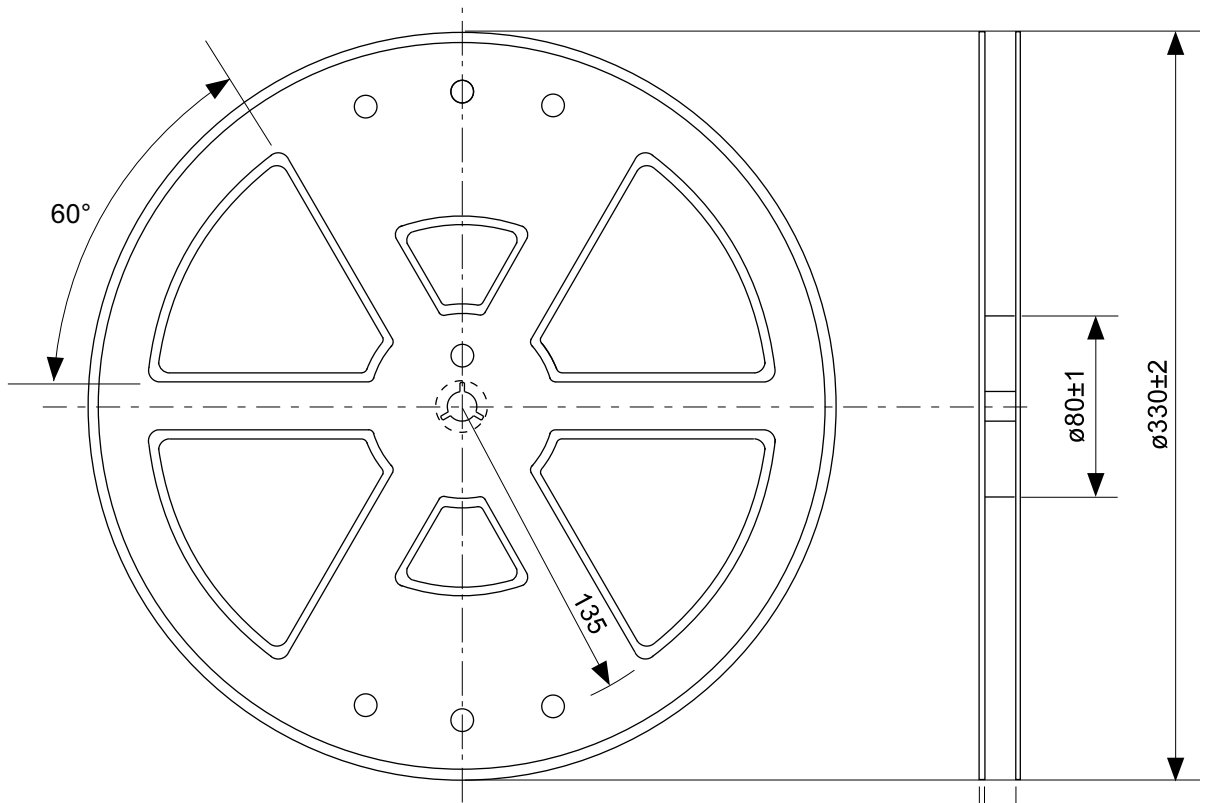

Enlarged drawing in the central part

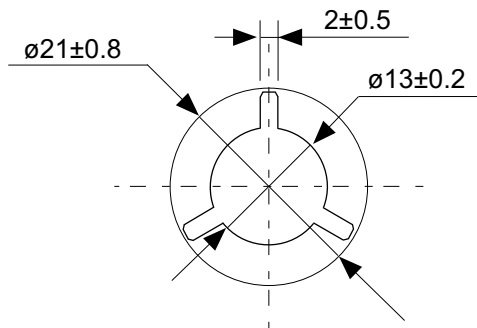

No. FJ008-D-R-S1-1.0

TITLE	SOP8J-D-Reel		
No.	FJ008-D-R-S1-1.0		
SCALE		QTY.	4,000
UNIT	mm		

SII Semiconductor Corporation

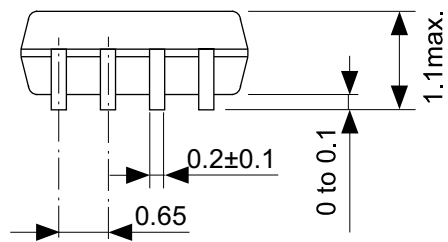
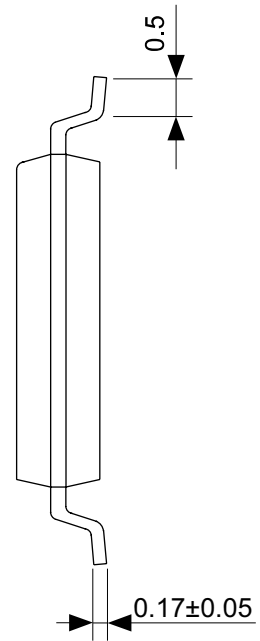
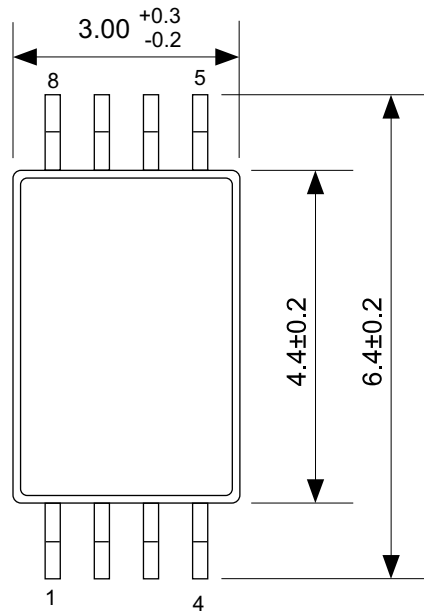

No. FT008-A-P-SD-1.1

TITLE	TSSOP8-E-PKG Dimensions
No.	FT008-A-P-SD-1.1
SCALE	
UNIT	mm
SII Semiconductor Corporation	

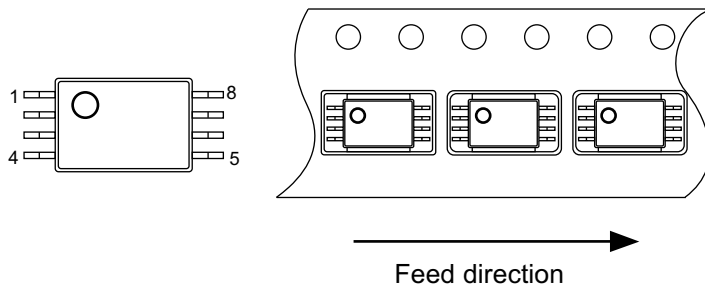
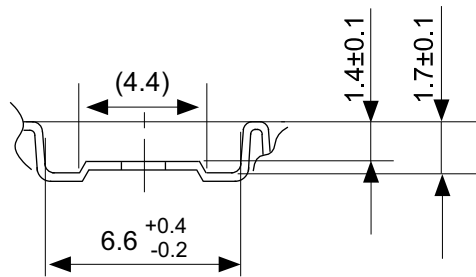
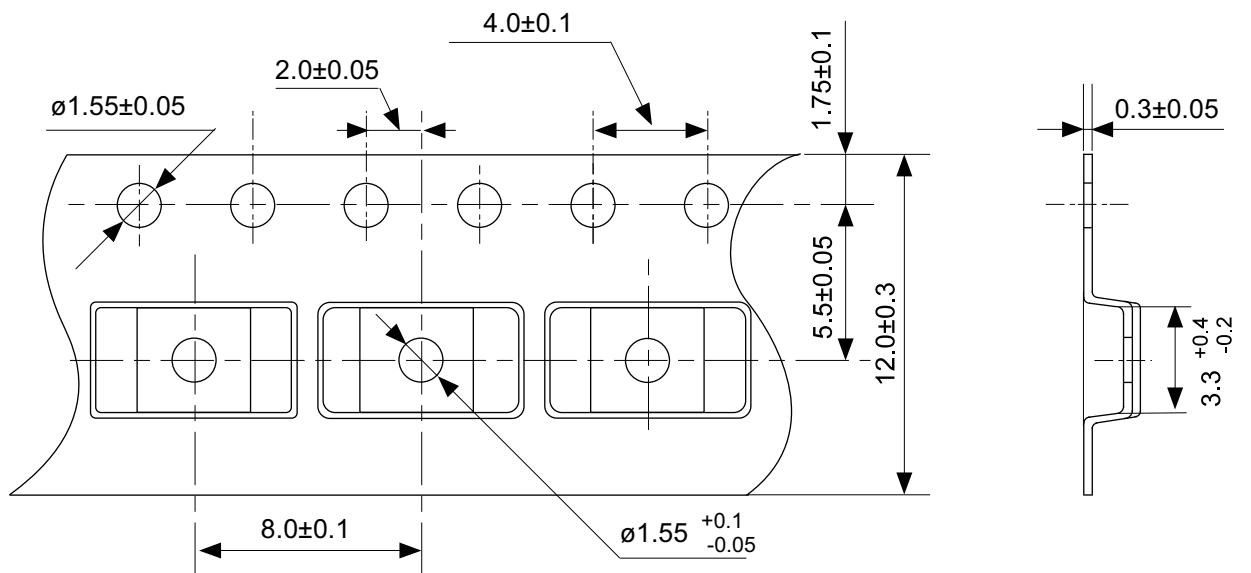

No. FT008-E-C-SD-1.0

TITLE	TSSOP8-E-Carrier Tape
No.	FT008-E-C-SD-1.0
SCALE	
UNIT	mm
SII Semiconductor Corporation	

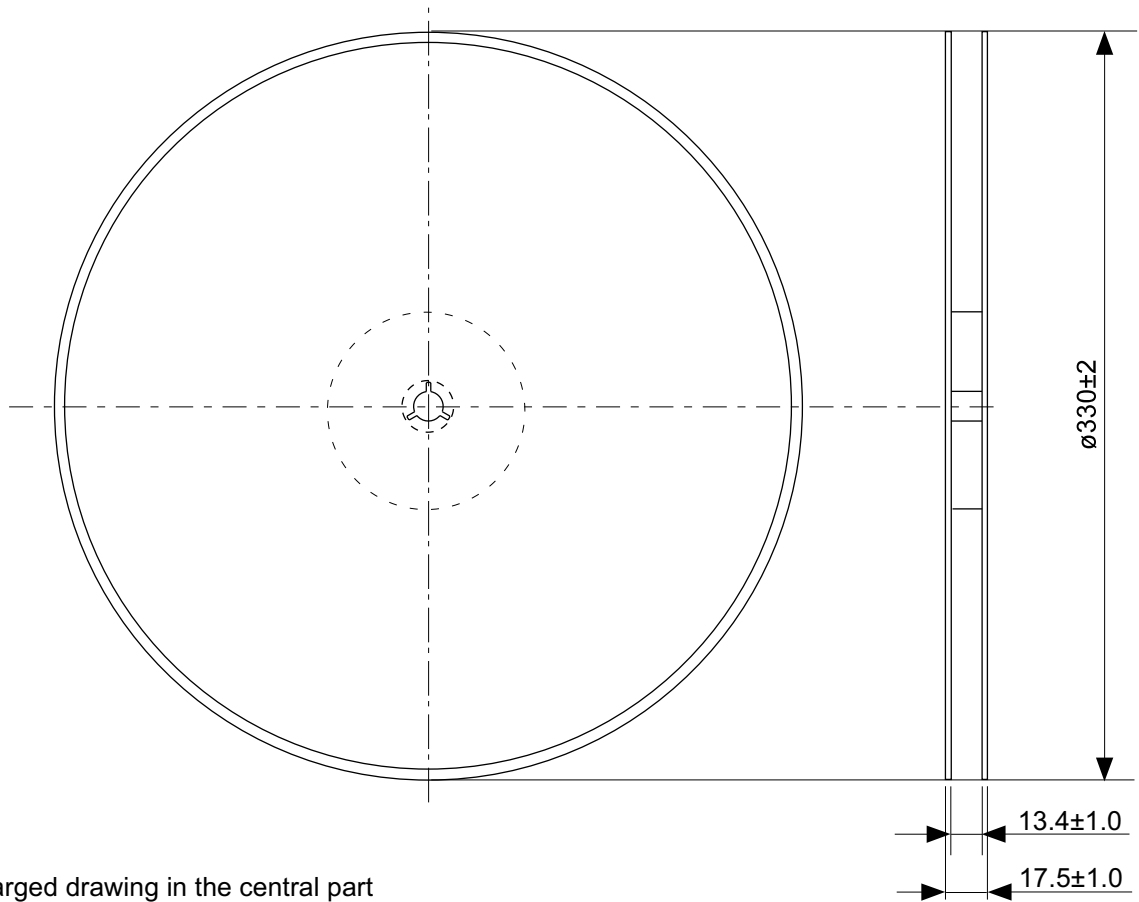

Enlarged drawing in the central part

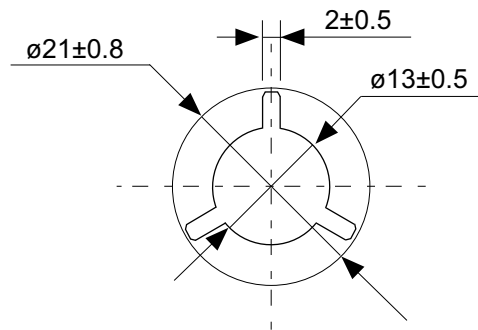

No. FT008-E-R-S1-1.0

TITLE	TSSOP8-E-Reel		
No.	FT008-E-R-S1-1.0		
SCALE		QTY.	4,000
UNIT	mm		
SII Semiconductor Corporation			

Disclaimers (Handling Precautions)

1. All the information described herein (product data, specifications, figures, tables, programs, algorithms and application circuit examples, etc.) is current as of publishing date of this document and is subject to change without notice.
2. The circuit examples and the usages described herein are for reference only, and do not guarantee the success of any specific mass-production design.
SII Semiconductor Corporation is not responsible for damages caused by the reasons other than the products or infringement of third-party intellectual property rights and any other rights due to the use of the information described herein.
3. SII Semiconductor Corporation is not responsible for damages caused by the incorrect information described herein.
4. Take care to use the products described herein within their specified ranges. Pay special attention to the absolute maximum ratings, operation voltage range and electrical characteristics, etc.
SII Semiconductor Corporation is not responsible for damages caused by failures and/or accidents, etc. that occur due to the use of products outside their specified ranges.
5. When using the products described herein, confirm their applications, and the laws and regulations of the region or country where they are used and verify suitability, safety and other factors for the intended use.
6. When exporting the products described herein, comply with the Foreign Exchange and Foreign Trade Act and all other export-related laws, and follow the required procedures.
7. The products described herein must not be used or provided (exported) for the purposes of the development of weapons of mass destruction or military use. SII Semiconductor Corporation is not responsible for any provision (export) to those whose purpose is to develop, manufacture, use or store nuclear, biological or chemical weapons, missiles, or other military use.
8. The products described herein are not designed to be used as part of any device or equipment that may affect the human body, human life, or assets (such as medical equipment, disaster prevention systems, security systems, combustion control systems, infrastructure control systems, vehicle equipment, traffic systems, in-vehicle equipment, aviation equipment, aerospace equipment, and nuclear-related equipment), excluding when specified for in-vehicle use or other uses. Do not use those products without the prior written permission of SII Semiconductor Corporation. Especially, the products described herein cannot be used for life support devices, devices implanted in the human body and devices that directly affect human life, etc.
Prior consultation with our sales office is required when considering the above uses.
SII Semiconductor Corporation is not responsible for damages caused by unauthorized or unspecified use of our products.
9. Semiconductor products may fail or malfunction with some probability.
The user of these products should therefore take responsibility to give thorough consideration to safety design including redundancy, fire spread prevention measures, and malfunction prevention to prevent accidents causing injury or death, fires and social damage, etc. that may ensue from the products' failure or malfunction.
The entire system must be sufficiently evaluated and applied on customer's own responsibility.
10. The products described herein are not designed to be radiation-proof. The necessary radiation measures should be taken in the product design by the customer depending on the intended use.
11. The products described herein do not affect human health under normal use. However, they contain chemical substances and heavy metals and should therefore not be put in the mouth. The fracture surfaces of wafers and chips may be sharp. Take care when handling these with the bare hands to prevent injuries, etc.
12. When disposing of the products described herein, comply with the laws and ordinances of the country or region where they are used.
13. The information described herein contains copyright information and know-how of SII Semiconductor Corporation.
The information described herein does not convey any license under any intellectual property rights or any other rights belonging to SII Semiconductor Corporation or a third party. Reproduction or copying of the information described herein for the purpose of disclosing it to a third-party without the express permission of SII Semiconductor Corporation is strictly prohibited.
14. For more details on the information described herein, contact our sales office.

1.0-2016.01

