

SPECIFICATION	VALUE
NO. of PHASES	3
NO. of POLES	4
RATED VOLTAGE(V)	24
RATED CURRENT(A)	1.3±10%
RATED POWER(W)	20
RATED SPEED(RPM)	4000±10%
RATED TORQUE(mN.m)	48
NO LOAD CURRENT(A)	0.12
NO LOAD SPEED(RPM)	5800
SENSOR	HALL SENSOR
INSULATION CLASS	CLASS B
INSULATION RESISTANCE	100MΩ MIN @ 500VDC
DIELECTRIC STRANGTH TEST	500VAC for 1 MINUTE
BEARING TYPE	NMB BALL BERRING, C3

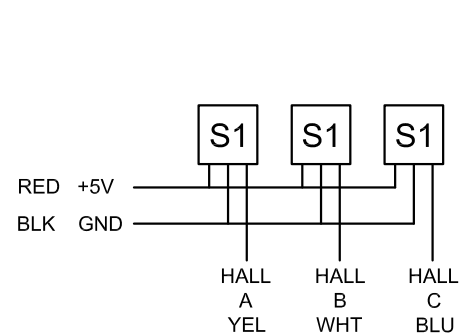

HALL LEAD: UL 1007 26AWG

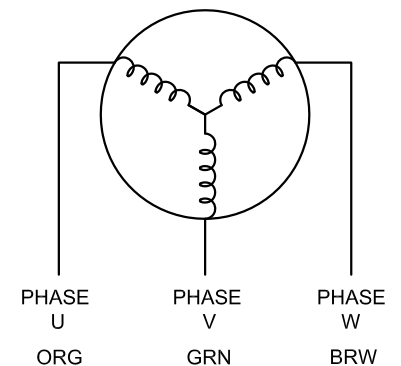

PHASE LEAD: UL1007 26AWG

STEPPERONLINE
Motors & Electronics

	APVD		
	CHKD		
1.5:1	DRN		
SCALE	SIGNATURE	DATE	

BRUSHLESS DC MOTOR

36BLR55-24-01