

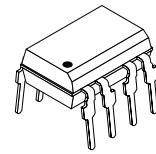

Optocoupler with Phototransistor Output

Description

The K814P/K824P/K844P consist of a phototransistor optically coupled to 2 gallium arsenide infrared-emitting diodes (reversed polarity) in an 4-lead up to 16-lead plastic dual inline package. The elements are mounted on one leadframe using a **coplanar technique**, providing a fixed distance between input and output for highest safety requirements.

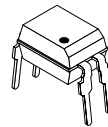
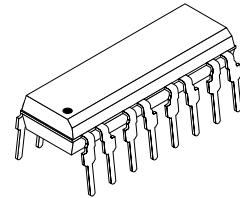

Applications

Feature phones, answering machines, PABX, fax machines

14925

Features

- Endstackable to 2.54 mm (0.1') spacing
- DC isolation test voltage $V_{IO} = 5 \text{ kV}$
- Low coupling capacitance of typical 0.3 pF
- **Current Transfer Ratio (CTR)** of typical 100%
- Low temperature coefficient of CTR
- Wide ambient temperature range
- **Underwriters Laboratory (UL) 1577** recognized, file number E-76222
- **CSA (C-UL) 1577** recognized, file number E-76222 – Double Protection
- Coupling System U

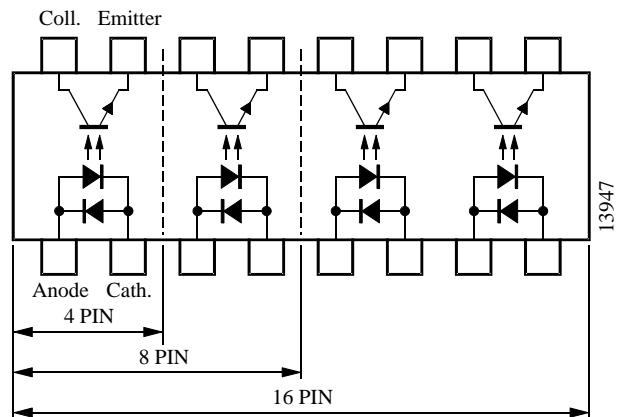

Order Instruction

| Ordering Code | CTR Ranking | Remarks |
|---------------|-------------|----------------------|
| K814P | < 20% | 4 Pin Single channel |
| K824P | < 20% | 8 Pin Dual channel |
| K844P | < 20% | 16 Pin Quad channel |



Absolute Maximum Ratings

Input (Emitter)

| Parameter | Test Conditions | Symbol | Value | Unit |
|-----------------------|---------------------------|-----------|-----------|------------|
| Reverse voltage | | V_R | 6 | V |
| Forward current | | I_F | ± 60 | mA |
| Forward surge current | $t_p \leq 10 \mu s$ | I_{FSM} | ± 1.5 | A |
| Power dissipation | $T_{amb} \leq 25^\circ C$ | P_V | 100 | mW |
| Junction temperature | | T_j | 125 | $^\circ C$ |

Output (Detector)

| Parameter | Test Conditions | Symbol | Value | Unit |
|---------------------------|-------------------------------|-----------|-------|------------|
| Collector emitter voltage | | V_{CEO} | 70 | V |
| Emitter collector voltage | | V_{ECO} | 7 | V |
| Collector current | | I_C | 50 | mA |
| Peak collector current | $t_p/T = 0.5, t_p \leq 10 ms$ | I_{CM} | 100 | mA |
| Power dissipation | $T_{amb} \leq 25^\circ C$ | P_V | 150 | mW |
| Junction temperature | | T_j | 125 | $^\circ C$ |

Coupler

| Parameter | Test Conditions | Symbol | Value | Unit |
|-------------------------------------|-------------------------------|---------------|-------------|------------|
| AC Isolation test voltage (RMS) | $t = 1 min$ | $V_{IO}^{1)}$ | 5 | kV |
| Total power dissipation | $T_{amb} \leq 25^\circ C$ | P_{tot} | 250 | mW |
| Operating ambient temperature range | | T_{amb} | -40 to +100 | $^\circ C$ |
| Storage temperature range | | T_{stg} | -55 to +125 | $^\circ C$ |
| Soldering temperature | 2 mm from case, $t \leq 10 s$ | T_{sd} | 260 | $^\circ C$ |

¹⁾ Related to standard climate 23/50 DIN 50014



Electrical Characteristics ($T_{amb} = 25^{\circ}\text{C}$)

Input (Emitter)

| Parameter | Test Conditions | Symbol | Min. | Typ. | Max. | Unit |
|-----------------|---------------------------|--------|------|------|------|---------------|
| Forward voltage | $I_F = \pm 50 \text{ mA}$ | V_F | | 1.25 | 1.6 | V |
| Reverse current | $V_R = \pm 6 \text{ V}$ | I_R | | | 10 | μA |

Output (Detector)

| Parameter | Test Conditions | Symbol | Min. | Typ. | Max. | Unit |
|---------------------------|---|-----------|------|------|------|------|
| Collector emitter voltage | $I_C = 100 \mu\text{A}$ | V_{CEO} | 70 | | | V |
| Emitter collector voltage | $I_E = 100 \mu\text{A}$ | V_{ECO} | 7 | | | V |
| Collector dark current | $V_{CE} = 20 \text{ V}, I_F = 0, E = 0$ | I_{CEO} | | | 100 | nA |

Coupler

| Parameter | Test Conditions | Symbol | Min. | Typ. | Max. | Unit |
|--------------------------------------|---|-------------|------|------|------|------|
| Collector emitter saturation voltage | $I_F = \pm 10 \text{ mA}, I_C = 1 \text{ mA}$ | V_{CEsat} | | | 0.3 | V |
| Cut-off frequency | $I_F = \pm 10 \text{ mA}, V_{CE} = 5 \text{ V}, R_L = 100 \Omega$ | f_c | | 100 | | kHz |
| Coupling capacitance | $f = 1 \text{ MHz}$ | C_k | | 0.3 | | pF |

Current Transfer Ratio (CTR)

| Parameter | Test Conditions | Type | Symbol | Min. | Typ. | Max. | Unit |
|-----------|--|------|--------|------|------|------|------|
| I_C/I_F | $V_{CE} = 5 \text{ V}, I_F = \pm 5 \text{ mA}$ | | CTR | 0.2 | | 3.0 | |

Switching Characteristics

| Parameter | Test Conditions | Symbol | Typ. | Unit |
|---------------|---|-----------|------|---------------|
| Delay time | $V_S = 5\text{ V}$, $I_C = 2\text{ mA}$, $R_L = 100\ \Omega$ see figure 1 | t_d | 3.0 | μs |
| Rise time | | t_r | 3.0 | μs |
| Fall time | | t_f | 4.7 | μs |
| Storage time | | t_s | 0.3 | μs |
| Turn-on time | | t_{on} | 6.0 | μs |
| Turn-off time | $V_S = 5\text{ V}$, $I_F = 10\text{ mA}$, $R_L = 1\text{ k}\Omega$ see figure 2 | t_{off} | 5.0 | μs |
| Turn-on time | | t_{on} | 9.0 | μs |
| Turn-off time | | t_{off} | 18.0 | μs |

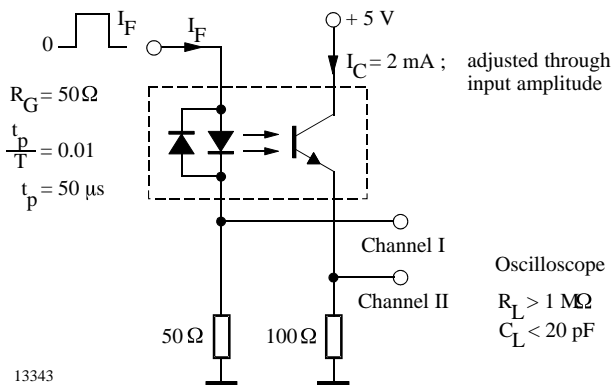

Figure 1. Test circuit, non-saturated operation

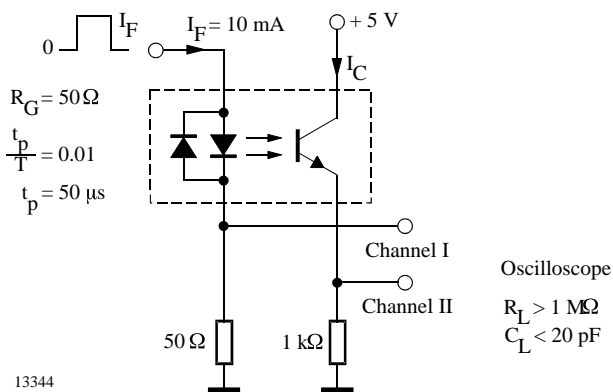

Figure 2. Test circuit, saturated operation

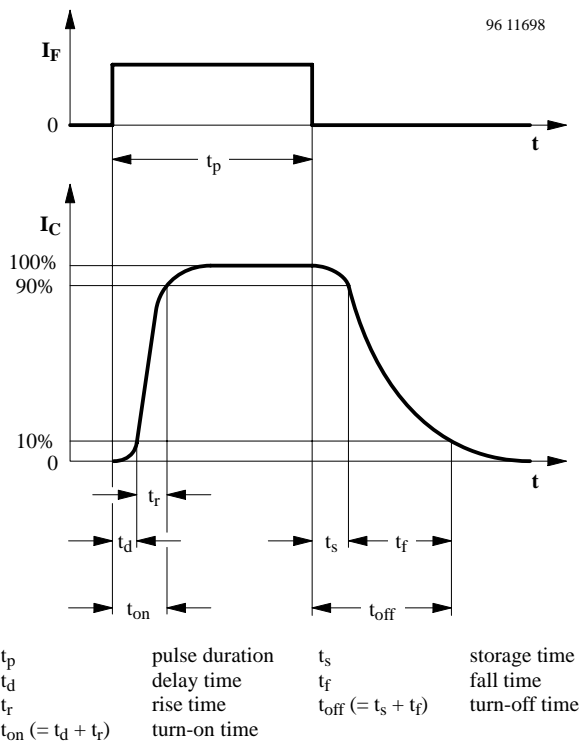

Figure 3. Switching times

Typical Characteristics ($T_{amb} = 25^{\circ}\text{C}$, unless otherwise specified)

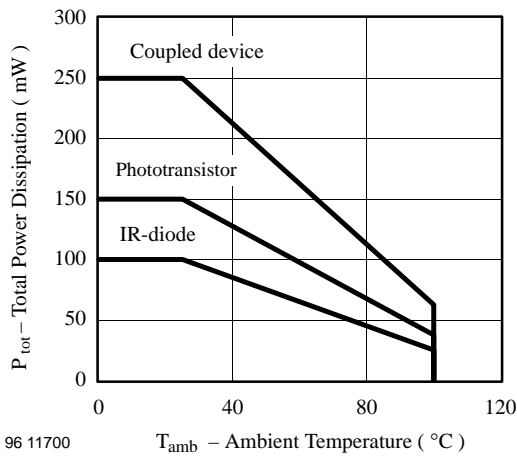

Figure 4. Total Power Dissipation vs. Ambient Temperature

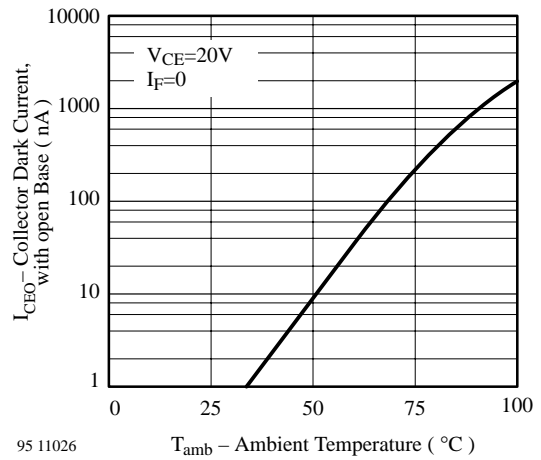

Figure 7. Collector Dark Current vs. Ambient Temperature

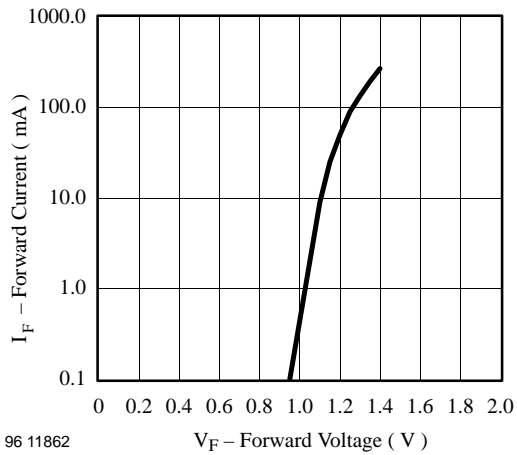

Figure 5. Forward Current vs. Forward Voltage

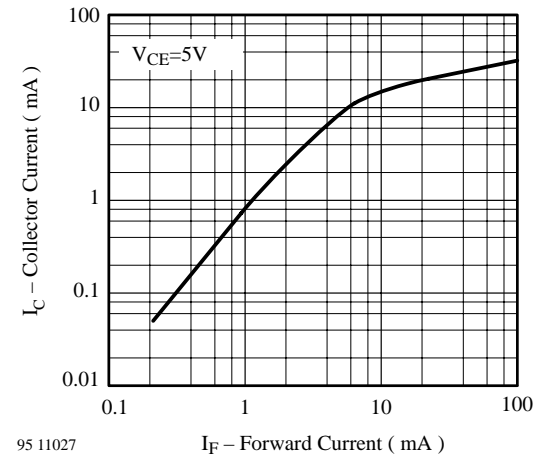

Figure 8. Collector Current vs. Forward Current

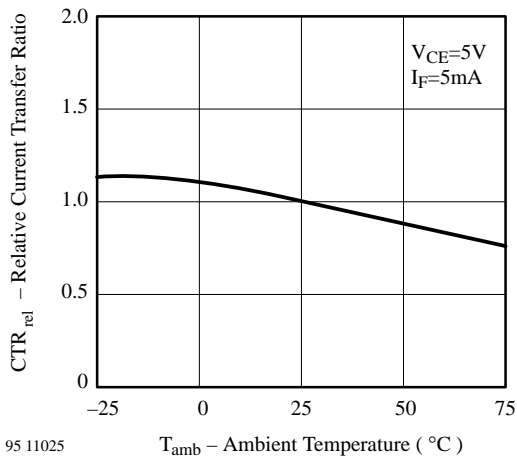

Figure 6. Relative Current Transfer Ratio vs. Ambient Temperature

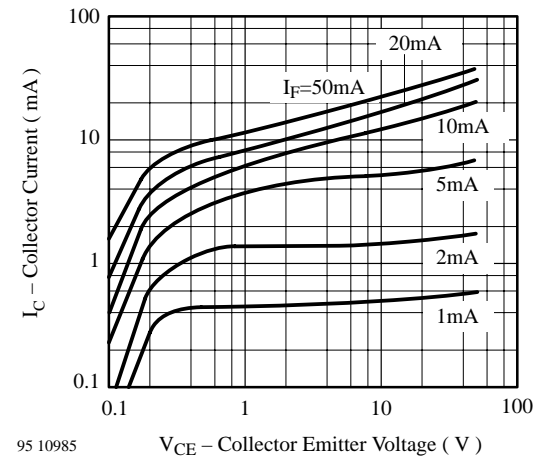
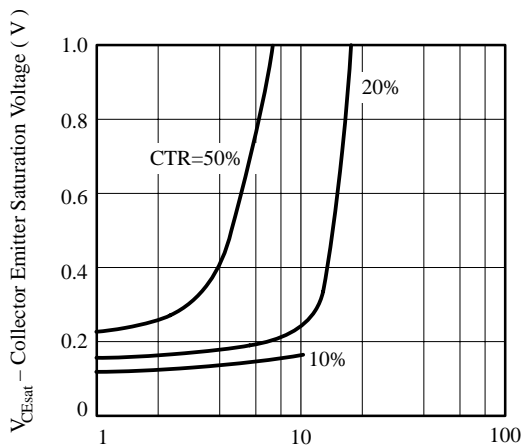

Figure 9. Collector Current vs. Collector Emitter Voltage



95 11028

I_C – Collector Current (mA)

Figure 10. Collector Emitter Saturation Voltage vs. Collector Current

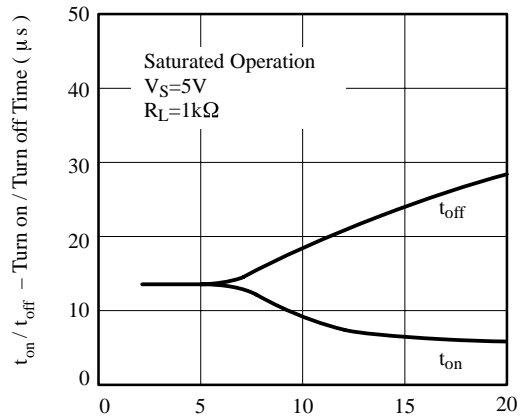

95 11031

I_F – Forward Current (mA)

Figure 12. Turn on / off Time vs. Forward Current

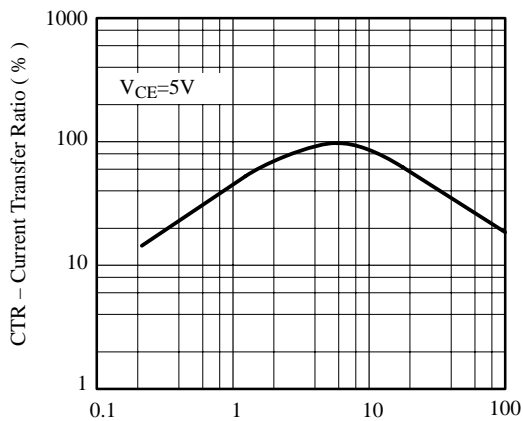

95 11029

I_F – Forward Current (mA)

Figure 11. Current Transfer Ratio vs. Forward Current

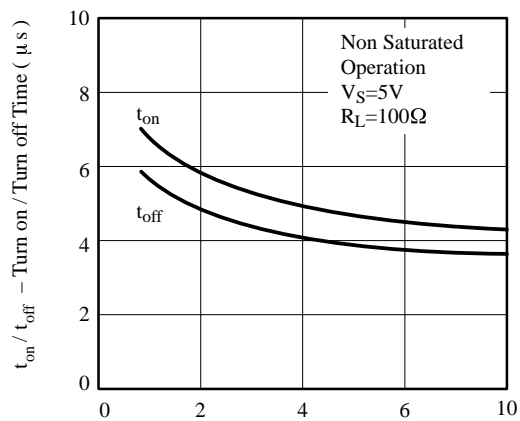

95 11030

I_C – Collector Current (mA)

Figure 13. Turn on / off Time vs. Collector Current

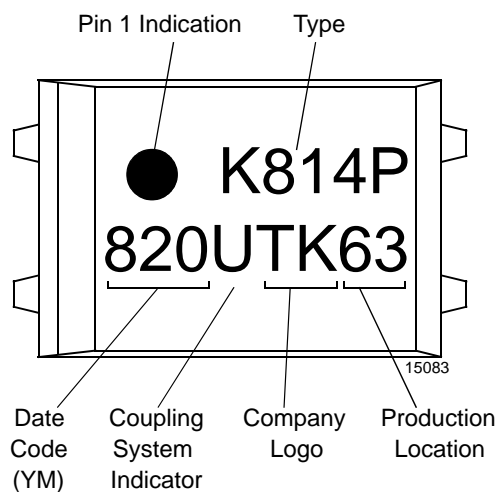
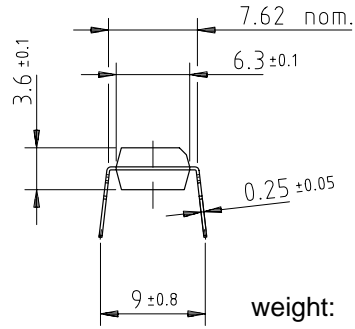
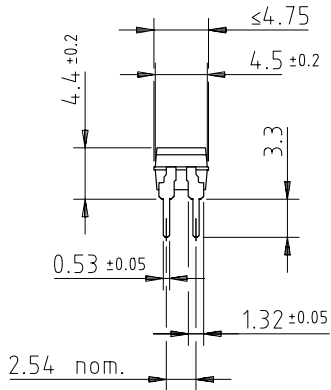

Figure 14. Marking example



Dimensions of K814P in mm



weight: ca. 0.25 g
 creepage distance: ≥ 6 mm
 air path: ≥ 6 mm

after mounting on PC board

E.g.:
 special Features: endstackable
 to 2.54mm (.100") spacing

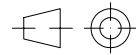
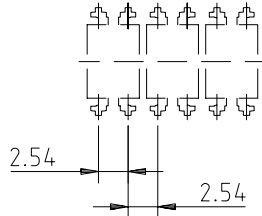
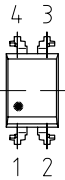

technical drawings
 according to DIN
 specifications

14789

Dimensions of K824P in mm

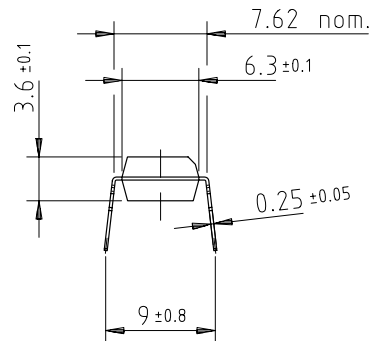
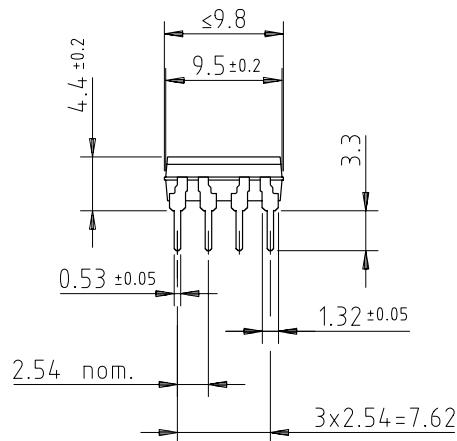

weight: ca. 0.55 g
 creepage distance: ≥ 6 mm
 air path: ≥ 6 mm

after mounting on PC board

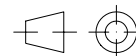
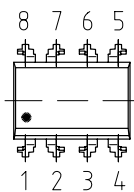

technical drawings
 according to DIN
 specifications

14784

K814P/ K824P/ K844P

Vishay Semiconductors



Dimensions of K844P in mm

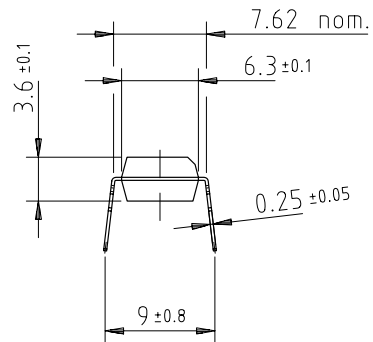
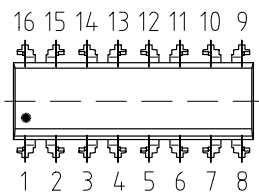
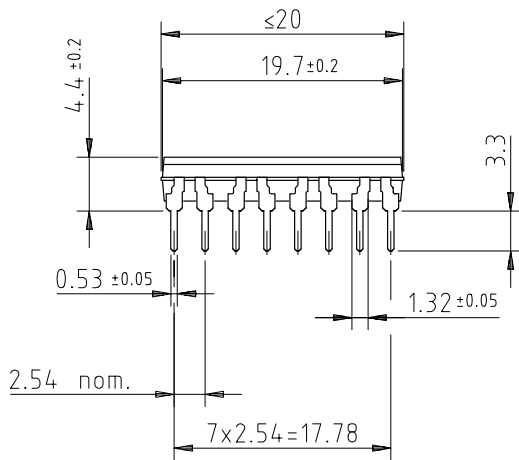

weight: ca. 1.0 g
creepage distance: ≥ 6 mm
air path: ≥ 6 mm

after mounting on PC board

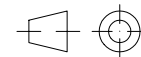

technical drawings
according to DIN
specifications

14783



Ozone Depleting Substances Policy Statement

It is the policy of **Vishay Semiconductor GmbH** to

1. Meet all present and future national and international statutory requirements.
2. Regularly and continuously improve the performance of our products, processes, distribution and operating systems with respect to their impact on the health and safety of our employees and the public, as well as their impact on the environment.

It is particular concern to control or eliminate releases of those substances into the atmosphere which are known as ozone depleting substances (ODSs).

The Montreal Protocol (1987) and its London Amendments (1990) intend to severely restrict the use of ODSs and forbid their use within the next ten years. Various national and international initiatives are pressing for an earlier ban on these substances.

Vishay Semiconductor GmbH has been able to use its policy of continuous improvements to eliminate the use of ODSs listed in the following documents.

1. Annex A, B and list of transitional substances of the Montreal Protocol and the London Amendments respectively
2. Class I and II ozone depleting substances in the Clean Air Act Amendments of 1990 by the Environmental Protection Agency (EPA) in the USA
3. Council Decision 88/540/EEC and 91/690/EEC Annex A, B and C (transitional substances) respectively.

Vishay Semiconductor GmbH can certify that our semiconductors are not manufactured with ozone depleting substances and do not contain such substances.

We reserve the right to make changes to improve technical design and may do so without further notice.

Parameters can vary in different applications. All operating parameters must be validated for each customer application by the customer. Should the buyer use Vishay Semiconductors products for any unintended or unauthorized application, the buyer shall indemnify Vishay Semiconductors against all claims, costs, damages, and expenses, arising out of, directly or indirectly, any claim of personal damage, injury or death associated with such unintended or unauthorized use.

Vishay Semiconductor GmbH, P.O.B. 3535, D-74025 Heilbronn, Germany
Telephone: 49 (0) 7131 67 2831, Fax number: 49 (0) 7131 67 2423