

5-Bit Programmable, High Frequency Multi-phase PWM Controller

General Description

The LM2720 provides an attractive solution for power supplies of high power microprocessors exhibiting ultra fast load transients. Compared to a conventional single-phase supply, an LM2720 based multi-phase supply distributes the thermal and electrical loading among components in multiple phases and greatly reduces the corresponding stress in each component. The LM2720 can be programmed to control either a 3-phase converter or a 4-phase converter. Phase shift among the phases is 120° in the case of three phase and 90° with four-phase. Because the power channels are out of phase, there can be significant ripple cancellation for both the input and output current, resulting in reduced input and output capacitor size. Due to the nominal operating frequency of 2 MHz per phase, the size of the output inductors can be greatly reduced which results in a much faster load transient response and a dramatically shrunk output capacitor bank. Microprocessor power supplies with all surface mount components can be easily built.

The internal high speed transconductance amplifier guarantees good dynamic performance.

The internal master clock frequency of up to 8 MHz is set by an external reference resistor. An external clock of 10 MHz can also be used to drive the chip to achieve frequency control and multi-chip operation.

The LM2720 also provides input under-voltage lock-out with hysteresis, input over-current protection and output voltage power good detection.

Features

- Ultra fast load transient response
- Enables all surface-mount-design
- Selectable 2, 3, 4 phase operation
- Clock frequency from 40 kHz to 10 MHz
- Precision load current sharing
- 5-bit programmable from 3.5V to 1.3V
- VID code compatible to VRM 8.X specification
- Output voltage is 2.0V for VID code 11111
- Selectable internal or external clock
- Digital 16-step soft start
- Input under-voltage lock-out, over-current protection
- Open-drain power good signal output

Applications

- Servers and workstations
- High current, ultra-fast transient microprocessors

Pin Configuration

24-Pin Plastic SOIC

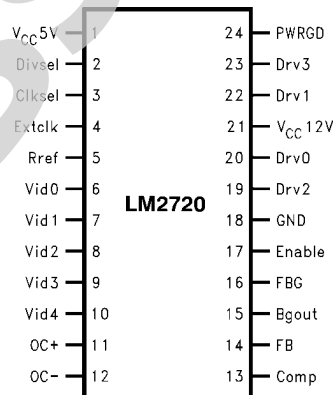

10132201

Top View
See NS Package Number M24B

Absolute Maximum Ratings (Note 1)

If Military/Aerospace specified devices are required, please contact the National Semiconductor Sales Office/Distributors for availability and specifications.

V_{CC5V}	7V
PWRGD	$(V_{CC5V} + 0.2V)$
V_{CC12V}	20V
Junction Temperature	125°C
Power Dissipation (Note 2)	1.6W

Storage Temperature	-65°C to +150°C
ESD Susceptibility (Note 8)	2 kV
Soldering Time, Temperature	10 sec., 300°C

Operating Ratings (Note 1)

V_{CC5V}	4.5V to 5.5V
V_{CC12V}	10V to 18V
Junction Temperature Range	0°C to 70°C

Electrical Characteristics

$V_{CC5V} = 5V$, $V_{CC12V} = 12V$ unless otherwise specified. Typical and limits appearing in plain type apply for $T_A = T_J = +25^\circ\text{C}$. Limits appearing in **boldface** type apply over the entire operating temperature range.

Symbol	Parameter	Conditions	Min	Typ	Max	Units
V_{DACOUT}	5-bit DAC Output Voltage	(Note 3)	N-1.5%	N	N+1.5%	V
I_{CC12V}	Quiescent V_{CC12V} Current	Enable = 5V, VID = 00001, DRV Outputs Floating		1	2	mA
I_{CC5V}	Operating V_{CC5V} Current	$V_{OUT} = 2.00V$		4.3	8	mA
V_{REF}	Rref Pin Voltage			1.225		V
V_{INL}	Vid0:4, Clksel, Divsel, and Enable Pins Logic Threshold	Logic Low (Note 4)		1.8	1.5	V
V_{INH}		Logic High (Note 5)	3.5	2.8		V
I_{INL}	Vid0:4 and Enable Pins Internal Pullup Current	The Corresponding Pin = 0V	60	100	140	μA
	Clksel, Divsel Pins Internal Pullup Current		-10	0	10	
	Gate Driver Resistance When Sinking Current	$I_{SINK} = 50 \mu\text{A}$, $V_{CC12V} = 14V$		12		Ω
V_{DRV}	DRV0:3 Output Voltage	$I_{DRV} = 10 \text{ mA}$, $V_{CC12V} = 14V$	$V_{CC12V} - 1.5V$	$V_{CC12V} - 1.0V$		V
t_{fall}	DRV0:3 Fall Time	(Note 6)		7		ns
I_{SRC}	DRV0:3 Source Current	DRV0:3 = 0V, $V_{CC12V} = 14V$	40	60		mA
I_{SINK}	DRV0:3 Sink Current	DRV0:3 = 5V, $V_{CC12V} = 14V$	90	160	250	mA
$V_{B_{gOUT}}$	B_{gOUT} Voltage	Current Limit Not Activated		4		V
		Current Limit Activated		0		
$I_{B_{gOUT}}$	B_{gOUT} Sink Current	$B_{gOUT} = 1V$	1.0	2.4	5	mA
I_{FB}	FB Pin Bias Current	FB = 2V		30		nA
F_{OSC}	Oscillator Frequency	8.02k Ω from Rref Pin to Ground	7.0	8.0	8.7	MHz
Δ_D	DRV0:3 Duty Cycle Match	Duty Cycle = 50%	-1		+1	%
Δ_{ph}	DRV0:3 Phase Accuracy	Duty Cycle = 50%, $F_{clock} = 8 \text{ MHz}$	-1		+1	Deg
T_{off}	PWM Off time	Divide by 4		22		%
		Divide by 3		22		
V_{PWRGD}	Power Good Detection Window, ΔV_{OUT}	$1.3V \leq V_{OUT} \leq 1.9V$		± 100		mV

Symbol	Parameter	Conditions	Min	Typ	Max	Units
	Hysteresis			50		
	Power Good Detection Window, ΔV_{OUT}	$2V \leq V_{OUT} \leq 3.5V$		± 150		
	Hysteresis			50		
I_{PWRGD}	Power Good Sink Current	$V_{PWRGD} = 0.4V$	0.8	1		mA
V_{OCC_CM}	Over-current Comparator Common Mode Range		3		12	V
IB_{OC+}	OC+ Input Bias Current	$V_{IN} = 5V, OC+ = 5V, OC- = 4V$	100	145	200	μA
IB_{OC-}	OC- Input Bias Current	$V_{IN} = 5V, OC+ = 6V, OC- = 5V$	85	120	165	μA
V_{OS_OCC}	Over-current Comparator Input Offset Voltage	$V_{IN} = 5V$ $V_{IN} = 12V$	2	16 21	42	mV
D_{MAX}	Maximum Duty Cycle	$FB = 0V$		78		%
gm	Error Amplifier Transconductance			1.36		mmho
V_{ramp}	Ramp Signal Peak-to-Peak Amplitude			2		V
I_{comp}	COMP Pin Source Current		250	360	550	μA
I_{comp}	COMP Pin Sink Current		160	260	400	μA
V_{comp_hi}	COMP Pin High Clamp			2.9		V
V_{comp_lo}	COMP Pin Low Clamp			0.19		V
V_{POR}	Power On Reset Trip Point	<i>Vcc5V Pin Voltage Rising</i> <i>Vcc5V Pin Voltage Falling</i>		4.0 3.6		V
	Vcc12V Minimum Working Voltage	(Note 7)		3.8		V
t_{SS}	Soft Start Delay	$F_{OSC} = 8MHz$		1.6		ms

Note 1: Absolute Maximum Ratings are limits beyond which damage to the device may occur. **Operating ratings** do not imply guaranteed performance limits.

Note 2: Maximum allowable power dissipation is a function of the maximum junction temperature, T_{JMAX} , the junction-to-ambient thermal resistance, θ_{JA} , and the ambient temperature, T_A . The maximum allowable power dissipation at any ambient temperature is calculated using: $P_{MAX} = (T_{JMAX} - T_A)/\theta_{JA}$. The junction-to-ambient thermal resistance, θ_{JA} , for LM2720 is 78°C/W. For a T_{JMAX} of 150°C and T_A of 25°C, the maximum allowable power dissipation is 1.6W.

Note 3: The letter **N** stands for the typical output voltages appearing in *italic boldface* type in Table 1.

Note 4: Max value of logic low means any voltage below this value is guaranteed to be taken as logic low whereas a voltage higher than this value is not guaranteed to be taken as a logic low.

Note 5: Min value of logic high means any voltage above this value is guaranteed to be taken as logic high whereas a voltage lower than this value is not guaranteed to be taken as a logic high.

Note 6: When driving bipolar FET drivers in the typical application circuit.

Note 7: When Vcc12V pin goes below this voltage, all DRV pins go to 0V.

Note 8: ESD ratings is based on the human body model, 100pF discharged through 1.5k Ω .

TABLE 1. 5-Bit DAC Output Voltage Table

Symbol	Parameter	Conditions	Typical	Units
V_{DACOUT}	5-Bit DAC Output Voltages for Different VID Codes	VID4:0 = 01111	1.30	V
		VID4:0 = 01110	1.35	
		VID4:0 = 01101	1.40	
		VID4:0 = 01100	1.45	
		VID4:0 = 01011	1.50	
		VID4:0 = 01010	1.55	
		VID4:0 = 01001	1.60	
		VID4:0 = 01000	1.65	
		VID4:0 = 00111	1.70	
		VID4:0 = 00110	1.75	
		VID4:0 = 00101	1.80	
		VID4:0 = 00100	1.85	
		VID4:0 = 00011	1.90	
		VID4:0 = 00010	1.95	
		VID4:0 = 00001	2.00	
		VID4:0 = 00000	2.05	
		VID4:0 = 11111	2.0	
		VID4:0 = 11110	2.1	
		VID4:0 = 11101	2.2	
		VID4:0 = 11100	2.3	
		VID4:0 = 11011	2.4	
		VID4:0 = 11010	2.5	
		VID4:0 = 11001	2.6	
		VID4:0 = 11000	2.7	
		VID4:0 = 10111	2.8	
		VID4:0 = 10110	2.9	
		VID4:0 = 10101	3.0	
		VID4:0 = 10100	3.1	
		VID4:0 = 10011	3.2	
		VID4:0 = 10010	3.3	
VID4:0 = 10001	3.4			
VID4:0 = 10000	3.5			

Pin Description

Pin	Pin Name	Pin Function
1	Vcc5V	Supply Voltage Input (5V nominal)
2	Divsel	Selects Phase Mode. Logic low selects 4 phase. Logic high selects 3 phase. 2 phase operation is achieved by using 2 outputs in 4 phase mode.
3	Clkssel	Clock Select: Logic high selects internal clock. Logic low selects external clock.
4	Extclk	External Clock Input. Output frequency = Clock Input / No. of Phases. Connect to Vcc5V to select internal clock.
5	Rref	Connects to external reference resistor. Sets the operating frequency of the internal clock and the ramp time for the PWM. Reference voltage at this pin is 1.26V.
6	Vid0	5-Bit DAC Input (LSB).
7	Vid1	5-Bit DAC Input.
8	Vid2	5-Bit DAC Input.
9	Vid3	5-Bit DAC Input.
10	Vid4	5-Bit DAC Input (MSB)
11	OC+	Over-current Comparator. Non-inverting input.
12	OC-	Over-current Comparator. Inverting input.
13	COMP	Compensation Pin. This is the output of the internal transconductance amplifier. Compensation network should be connected between this pin and feedback ground FBG.
14	FB	Feedback Input. Normally Kelvin connected to supply output.
15	Bgout	Current Limit Flag. Goes to logic low when current limit is activated. When over-current condition is removed, this pin is weakly pulled up to Vcc5V.
16	FBG	Feedback Ground. This pin should be connected to the ground at the supply output.
17	ENABLE	Output Enable Pin. Tie to logic high to enable and logic low to disable.
18	GND	Power Ground Pin.
19	DRV2	Phase 2 Output.
20	DRV0	Phase 0 Output.
21	Vcc12V	Supply Voltage for FET Drivers DRV0:3.
22	DRV1	Phase 1 Output
23	DRV3	Phase 3 Output.
24	PWRGD	Power Good. This is an open-drain output that goes low (low impedance to ground) when the output voltage travels out of the threshold window, and resume to open-drain state when V_{OUT} recovers into the 50mV hysteresis window. The power good window threshold, i.e. $\pm 100\text{mV}$ for $1.3\text{V} \leq V_{OUT} \leq 1.9\text{V}$ or $\pm 150\text{mV}$ for $2\text{V} \leq V_{OUT} \leq 3.5\text{V}$, is automatically set according to VID code. Connect a 1nF capacitor to ground to filter out the switching noise coupling from DRV3 to this pin.

Block Diagram

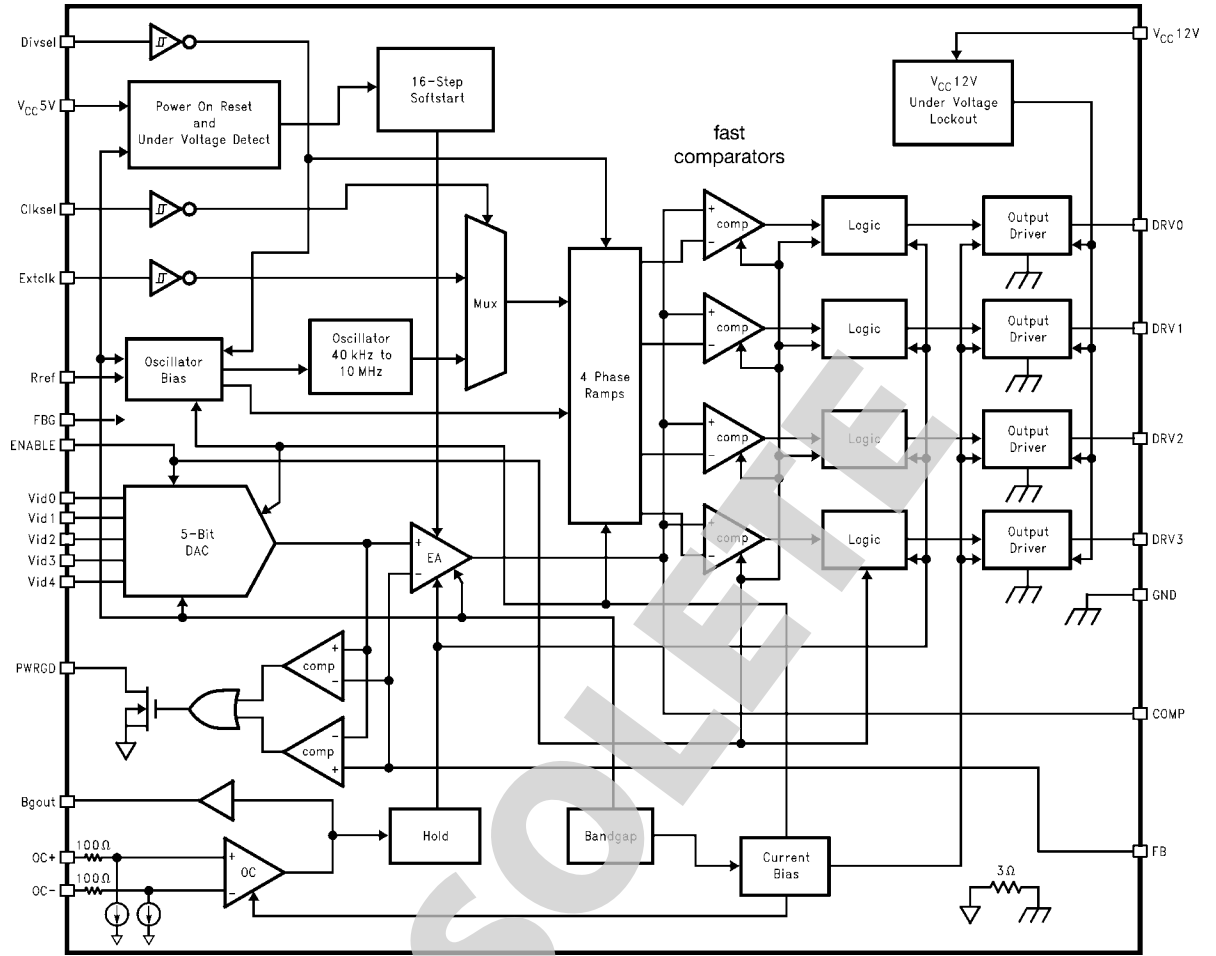

10132202

Typical Application

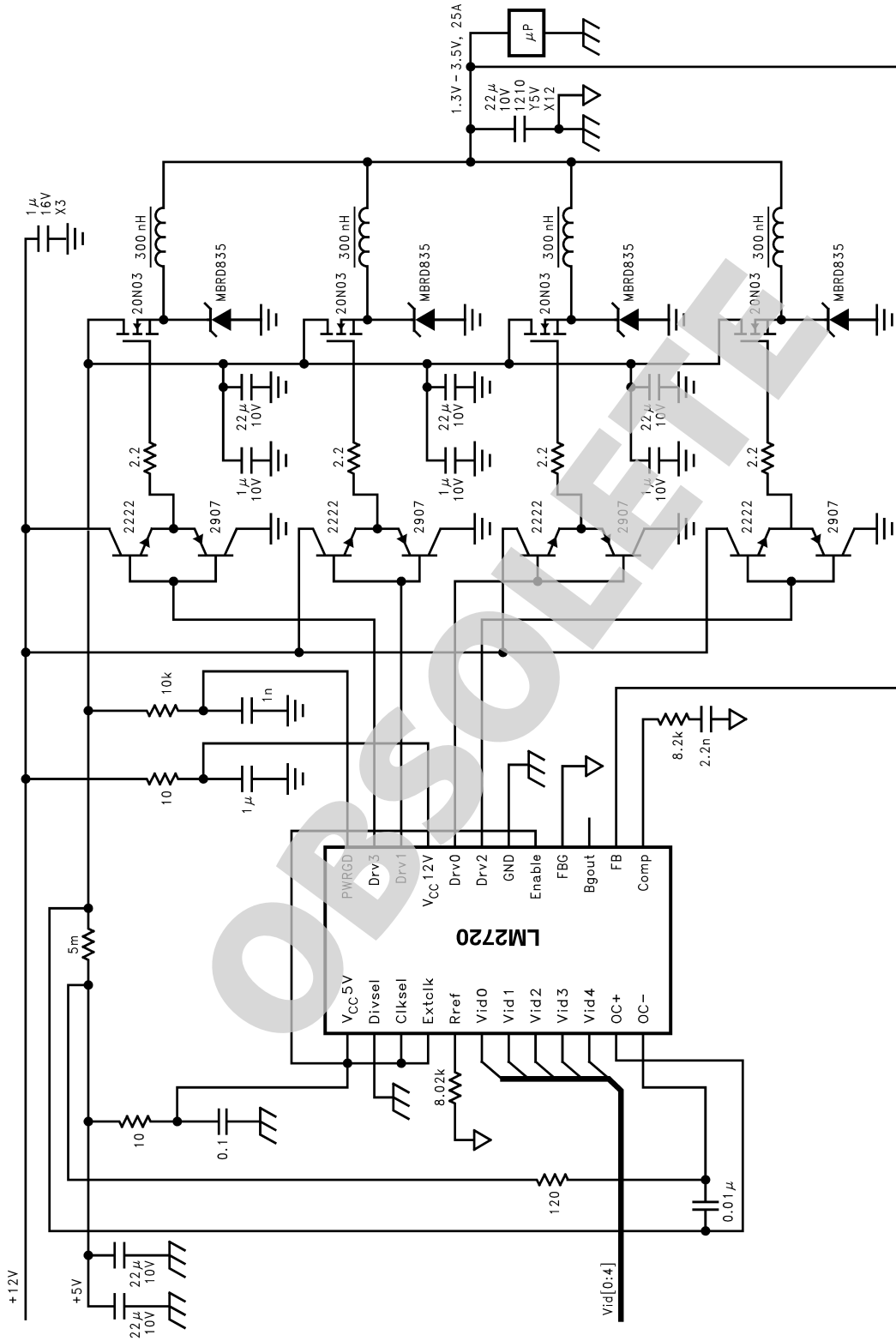

10132203

FIGURE 1.

Physical Dimensions inches (millimeters) unless otherwise noted

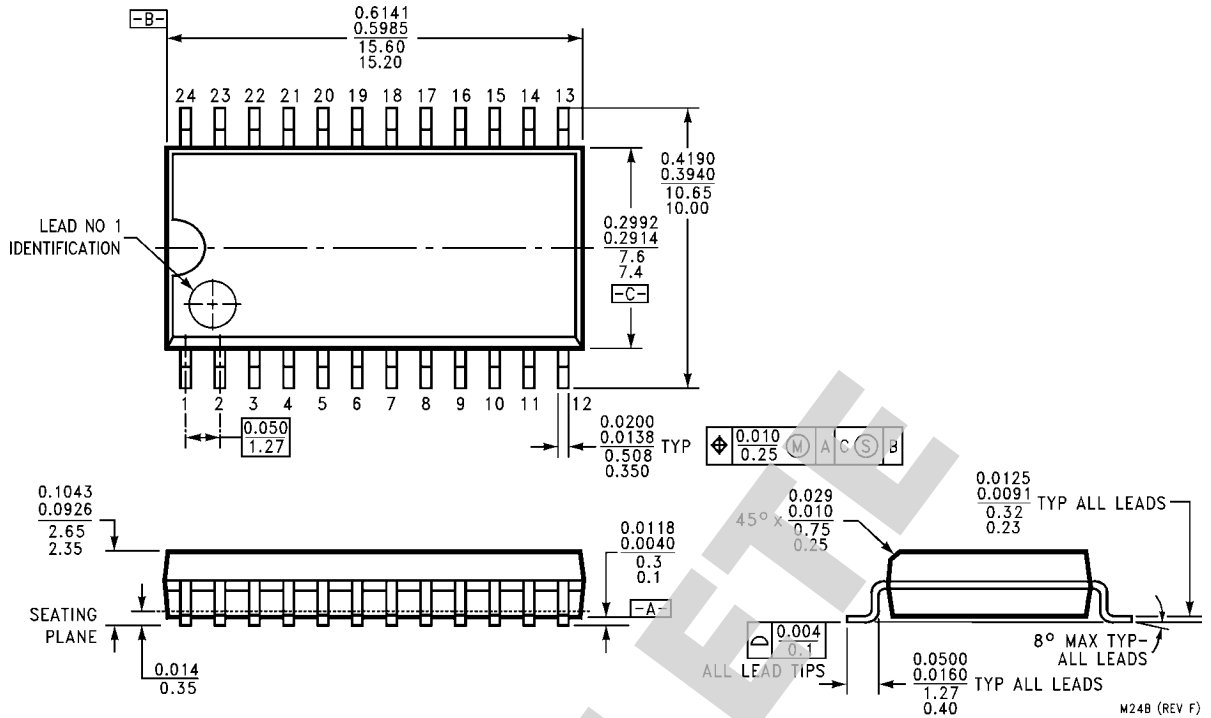

24-Lead Small Outline Package
Order Number LM2720M
NS Package Number M24B

M24B (REV F)

OBSOLETE

Notes

LM2720

OBSOLETE

Notes

For more National Semiconductor product information and proven design tools, visit the following Web sites at:

Products		Design Support	
Amplifiers	www.national.com/amplifiers	WEBENCH® Tools	www.national.com/webench
Audio	www.national.com/audio	App Notes	www.national.com/appnotes
Clock and Timing	www.national.com/timing	Reference Designs	www.national.com/refdesigns
Data Converters	www.national.com/adc	Samples	www.national.com/samples
Interface	www.national.com/interface	Eval Boards	www.national.com/evalboards
LVDS	www.national.com/lvds	Packaging	www.national.com/packaging
Power Management	www.national.com/power	Green Compliance	www.national.com/quality/green
Switching Regulators	www.national.com/switchers	Distributors	www.national.com/contacts
LDOs	www.national.com/ldo	Quality and Reliability	www.national.com/quality
LED Lighting	www.national.com/led	Feedback/Support	www.national.com/feedback
Voltage Reference	www.national.com/vref	Design Made Easy	www.national.com/easy
PowerWise® Solutions	www.national.com/powerwise	Solutions	www.national.com/solutions
Serial Digital Interface (SDI)	www.national.com/sdi	Mil/Aero	www.national.com/milaero
Temperature Sensors	www.national.com/tempsensors	SolarMagic™	www.national.com/solarmagic
Wireless (PLL/VCO)	www.national.com/wireless	Analog University®	www.national.com/AU

THE CONTENTS OF THIS DOCUMENT ARE PROVIDED IN CONNECTION WITH NATIONAL SEMICONDUCTOR CORPORATION ("NATIONAL") PRODUCTS. NATIONAL MAKES NO REPRESENTATIONS OR WARRANTIES WITH RESPECT TO THE ACCURACY OR COMPLETENESS OF THE CONTENTS OF THIS PUBLICATION AND RESERVES THE RIGHT TO MAKE CHANGES TO SPECIFICATIONS AND PRODUCT DESCRIPTIONS AT ANY TIME WITHOUT NOTICE. NO LICENSE, WHETHER EXPRESS, IMPLIED, ARISING BY ESTOPPEL OR OTHERWISE, TO ANY INTELLECTUAL PROPERTY RIGHTS IS GRANTED BY THIS DOCUMENT.

TESTING AND OTHER QUALITY CONTROLS ARE USED TO THE EXTENT NATIONAL DEEMS NECESSARY TO SUPPORT NATIONAL'S PRODUCT WARRANTY. EXCEPT WHERE MANDATED BY GOVERNMENT REQUIREMENTS, TESTING OF ALL PARAMETERS OF EACH PRODUCT IS NOT NECESSARILY PERFORMED. NATIONAL ASSUMES NO LIABILITY FOR APPLICATIONS ASSISTANCE OR BUYER PRODUCT DESIGN. BUYERS ARE RESPONSIBLE FOR THEIR PRODUCTS AND APPLICATIONS USING NATIONAL COMPONENTS. PRIOR TO USING OR DISTRIBUTING ANY PRODUCTS THAT INCLUDE NATIONAL COMPONENTS, BUYERS SHOULD PROVIDE ADEQUATE DESIGN, TESTING AND OPERATING SAFEGUARDS.

EXCEPT AS PROVIDED IN NATIONAL'S TERMS AND CONDITIONS OF SALE FOR SUCH PRODUCTS, NATIONAL ASSUMES NO LIABILITY WHATSOEVER, AND NATIONAL DISCLAIMS ANY EXPRESS OR IMPLIED WARRANTY RELATING TO THE SALE AND/OR USE OF NATIONAL PRODUCTS INCLUDING LIABILITY OR WARRANTIES RELATING TO FITNESS FOR A PARTICULAR PURPOSE, MERCHANTABILITY, OR INFRINGEMENT OF ANY PATENT, COPYRIGHT OR OTHER INTELLECTUAL PROPERTY RIGHT.

LIFE SUPPORT POLICY

NATIONAL'S PRODUCTS ARE NOT AUTHORIZED FOR USE AS CRITICAL COMPONENTS IN LIFE SUPPORT DEVICES OR SYSTEMS WITHOUT THE EXPRESS PRIOR WRITTEN APPROVAL OF THE CHIEF EXECUTIVE OFFICER AND GENERAL COUNSEL OF NATIONAL SEMICONDUCTOR CORPORATION. As used herein:

Life support devices or systems are devices which (a) are intended for surgical implant into the body, or (b) support or sustain life and whose failure to perform when properly used in accordance with instructions for use provided in the labeling can be reasonably expected to result in a significant injury to the user. A critical component is any component in a life support device or system whose failure to perform can be reasonably expected to cause the failure of the life support device or system or to affect its safety or effectiveness.

National Semiconductor and the National Semiconductor logo are registered trademarks of National Semiconductor Corporation. All other brand or product names may be trademarks or registered trademarks of their respective holders.

Copyright© 2009 National Semiconductor Corporation

For the most current product information visit us at www.national.com



www.national.com

**National Semiconductor
Americas Technical
Support Center**

Email: support@nsc.com
Tel: 1-800-272-9959

**National Semiconductor Europe
Technical Support Center**

Email: europe.support@nsc.com

**National Semiconductor Asia
Pacific Technical Support Center**

Email: ap.support@nsc.com

**National Semiconductor Japan
Technical Support Center**

Email: jpn.feedback@nsc.com