

ES21-CG1001

ES21

SAFETY COMMAND DEVICES

SICK
Sensor Intelligence.

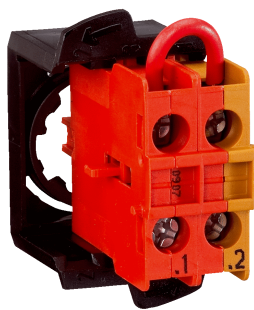

Ordering information

Type	Part no.
ES21-CG1001	6036139

Other models and accessories → www.sick.com/ES21



Detailed technical data

Features

Number of positive action N/C contacts	1
Number of N/O contacts	0
Contact module for panel mount version	✓

Safety-related parameters

B_{10d} parameter	250.000 switching cycles
----------------------------------	--------------------------

Interfaces

Connection type	
Conductor cross-section	≤ 2.5 mm ²
Contact	Screw connection

Electrical data

Operating data

Protection class	II (EN 50178)
Switching principle	Slow action switching element
Number of positive action N/C contacts	1
Number of N/O contacts	0
Usage category	AC-15/DC-13 (EN 60947-5-1)
Rated operating current (voltage)	3 A (250 V AC) 2 A (24 V DC)
Rated current (voltage) according to EN 61058-1	16 A (10 A) 250 V AC 10 A (6 A) 440 V AC
Rated insulation voltage U_i	600 V
Switching voltage	≥ 5 V DC
Switching current	≥ 1 mA
Electrical life	1 x 10 ⁶ switching cycles ¹⁾

¹⁾ At rated load.

Mechanical data

Weight	60 g
Mounting version	Panel mount version
Mechanical life	1 x 10 ⁶ switching cycles

Ambient data

Ambient operating temperature	-30 °C ... +85 °C
Storage temperature	-50 °C ... +85 °C

Classifications

ECl@ss 5.0	27371228
ECl@ss 5.1.4	27371228
ECl@ss 6.0	27371244
ECl@ss 6.2	27371244
ECl@ss 7.0	27371244
ECl@ss 8.0	27371244
ECl@ss 8.1	27371244
ECl@ss 9.0	27371244
ETIM 5.0	EC002034
ETIM 6.0	EC002034
UNSPSC 16.0901	39121545

Dimensional drawing (Dimensions in mm (inch))

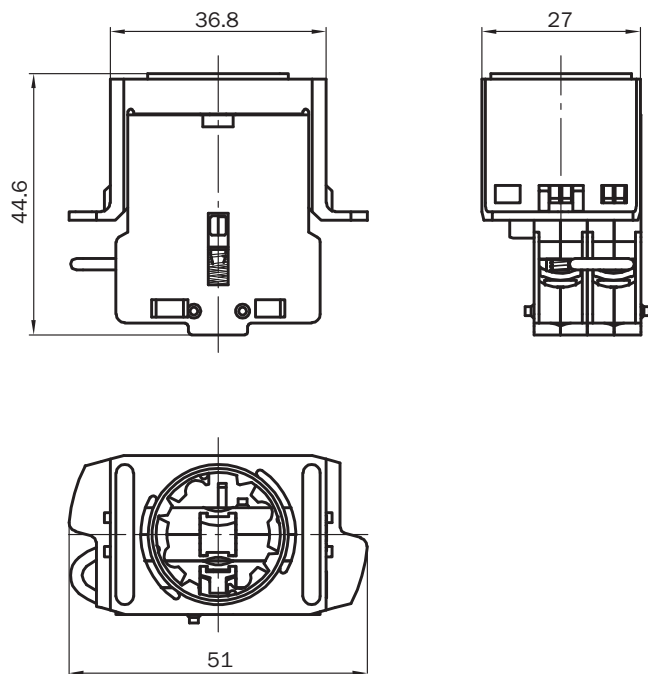

SICK AT A GLANCE

SICK is one of the leading manufacturers of intelligent sensors and sensor solutions for industrial applications. A unique range of products and services creates the perfect basis for controlling processes securely and efficiently, protecting individuals from accidents and preventing damage to the environment.

We have extensive experience in a wide range of industries and understand their processes and requirements. With intelligent sensors, we can deliver exactly what our customers need. In application centers in Europe, Asia and North America, system solutions are tested and optimized in accordance with customer specifications. All this makes us a reliable supplier and development partner.

Comprehensive services complete our offering: SICK LifeTime Services provide support throughout the machine life cycle and ensure safety and productivity.

For us, that is “Sensor Intelligence.”

WORLDWIDE PRESENCE:

Contacts and other locations –www.sick.com