

Flat Gain, Ultra-Wideband

# Monolithic Amplifier

PSA-14+

50Ω 0.01 to 10 GHz

## The Big Deal

- Ultra broadband performance
- Broadband without external matching components
- May be used as a replacement to ADA-4743<sup>a,b</sup>
- Suitable for low phase noise applications



SOT-343 PACKAGE

## Product Overview

PSA-14+ (RoHS compliant) is an advanced ultra-wideband amplifier fabricated using GaAs HBT technology and offers excellent gain flatness over a broad frequency range. In addition, the PSA-14+ has good input and output return loss over this frequency range without the need for external matching components. Lead finish is matte-tin. It has repeatable performance from lot to lot.

## Key Features

Feature	Advantages
Ultra Broad Band: 0.01 to 10 GHz	Broadband covering primary wireless communications bands: Cellular, PCS, LTE, WiMAX in a single amplifier.
No External Matching Components Required	PSA-14+ provides good Input and Output Return Loss of 16-41dB over 0.05 - 8 GHz without the need for any external matching components
Excellent ESD HBM: class 1C (1000 to <2000V) MM: class M2 (100 to <200V)	Simplifies ESD handling.
Low additive phase noise, typically -164 dBc/Hz @ 10 KHz offset	Ideal for low phase noise synthesizer applications

Notes:

a. Suitability for model replacement within a particular system must be determined by and is solely the responsibility of the customer based on, among other things, electrical performance criteria, stimulus conditions, application, compatibility with other components and environmental conditions and stresses.

b. The ADA-4743 part number is used for identification and comparison purposes only.



Flat Gain, Ultra-Wideband

# Monolithic Amplifier

0.01-10 GHz

## Product Features

- Gain, 16.5 dB typ. at 2 GHz
- Excellent return loss, 19 dB typ. input, 35 dB typ. output



Generic photo used for illustration purposes only

CASE STYLE: MMM1362

## PSA-14+

**+RoHS Compliant**

The +Suffix identifies RoHS Compliance. See our web site for RoHS Compliance methodologies and qualifications

## Typical Applications

- Base station infrastructure
- Test instruments
- MMDS & Wireless LAN
- LTE
- Satellite communication
- Avionics

## General Description

PSA-14+ (RoHS compliant) is an advanced ultra-wideband amplifier fabricated using GaAs HBT technology and offers excellent gain flatness over a broad frequency range. In addition, the PSA-14+ has good input and output return loss over this frequency range without the need for external matching components. Lead finish is matte-tin. It has repeatable performance from lot to lot.

### simplified schematic and pin description

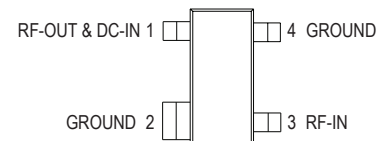
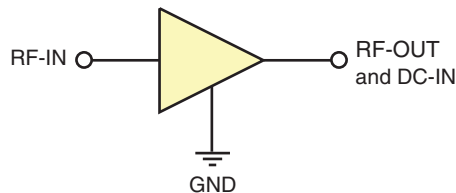

Function	Pin Number	Description
RF IN	3	RF input pin. This pin requires the use of an external DC blocking capacitor chosen for the frequency of operation.
RF-OUT and DC-IN	1	RF output and bias pin. DC voltage is present on this pin; therefore a DC blocking capacitor is necessary for proper operation. An RF choke is needed to feed DC bias without loss of RF signal due to the bias connection, as shown in "Recommended Application Circuit", Fig. 2
GND	2,4	Connections to ground. Use via holes as shown in "Suggested Layout for PCB Design" to reduce ground path inductance for best performance.



**Electrical Specifications at 25°C and Vcc=5V, R= 16.5Ω unless noted**

Parameter	Condition (GHz)	Min.	Typ.	Max.	Units
Frequency Range		0.01		10.0	GHz
Gain	0.05	-	16.2	-	dB
	0.85	-	17.1	-	
	2.0	14.8	16.5	18.1	
	6.0	-	14.1	-	
	8.0	-	13.7	-	
	10.0	-	12.8	-	
Gain Flatness	0.05-6.0		±1.7		dB
Input Return Loss	0.05	-	13.3	-	dB
	0.85	-	23.1	-	
	2.0	14	19.1	-	
	6.0	-	21.3	-	
	8.0	-	18.0	-	
	10.0	-	7.5	-	
Output Return Loss	0.05		14.1		dB
	0.85		30.0		
	2.0		34.9		
	6.0		18.4		
	8.0		18.9		
	10.0		8.7		
Reverse Isolation	6.0		21.8		dB
Output Power at 1dB Compression	0.05		16.7		dBm
	0.85		16.5		
	2.0		16.3		
	6.0		13.3		
	8.0		9.9		
	10.0		7.2		
Output IP3	0.2		29.6		dBm
	0.85		30.5		
	2.0		29.4		
	6.0		24.0		
	8.0		20.2		
	10.0		17.2		
Noise Figure	0.2		3.9		dB
	0.85		3.9		
	2.0		3.9		
	6.0		4.3		
	8.0		4.7		
	10.0		5.2		
Additive Phase Noise,	2.0 GHz, 10KHz offset		-164		dBc/Hz
Supply Operating Voltage (Vcc)		4.8	5.0	5.2	V
Device Operating Current			47	57	mA
Device Current Variation vs. Temperature <sup>2</sup>			42		μA/°C
Device Current Variation vs. Voltage			0.018		mA/mW
Thermal Resistance, junction-to-ground lead			156		°C/W

1. Measured on Mini-Circuits Characterization test board TB-PSA-14+. See Characterization Test Circuit (Fig. 1)
2. (Current at 85°C — Current at -45°C)/130

**Absolute Maximum Ratings<sup>3</sup>**

Parameter	Ratings
Operating Temperature (ground lead)	-40°C to 85°C
Storage Temperature	-65°C to 150°C
Operating Current at 5V (Vcc) & 16.5Ω resistor	100 mA
Power Dissipation	0.34 W
Input Power (CW)	28 dBm (5 min max.) 11 dBm (continuous)
DC Voltage on Pin 1	6 V

<sup>(3)</sup> Permanent damage may occur if any of these limits are exceeded. Electrical maximum ratings are not intended for continuous normal operation.

**Characterization Test Circuit**

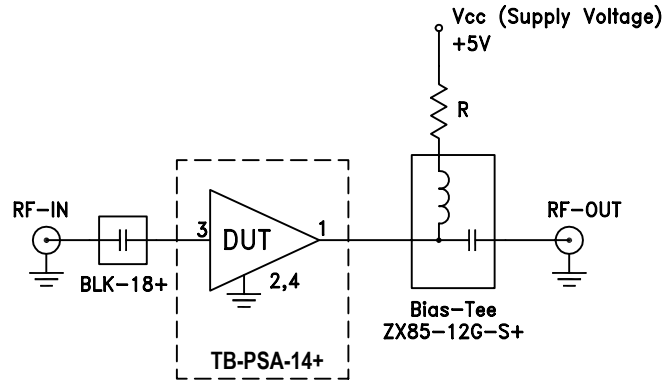
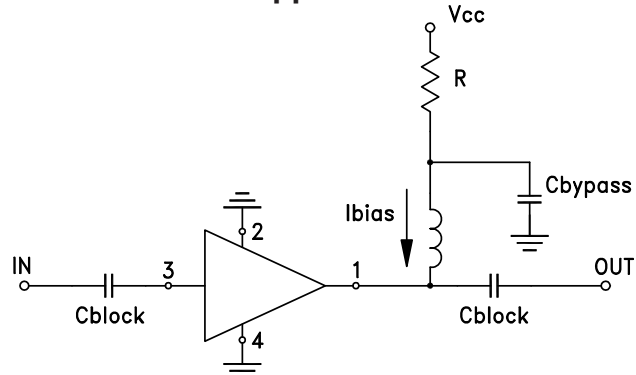

**Fig 1.** Block Diagram of Test Circuit used for characterization. (DUT soldered on Mini-Circuits Characterization test board TB-PSA-14+) Gain, Return loss, Output power at 1dB compression (P1 dB) , output IP3 (OIP3) and noise figure measured using Agilent’s N5242A PNA-X microwave network analyzer. (R=16.5Ω)

**Conditions:**

1. Gain and Return loss: Pin= -25dBm
2. Output IP3 (OIP3): Two tones, spaced 1 MHz apart, 0 dBm/tone at output.

**Recommended Application Circuit**



**Fig 2.** Test Board includes case, connectors, and components soldered to PCB (Cblock=0.001 μF, Cbypass=0.1 μF, R=16.5Ω)

**Product Marking**

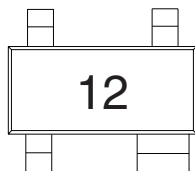

Marking may contain other features or characters for internal lot control

<b>Additional Detailed Technical Information</b>	
<i>additional information is available on our dash board. To access this information <a href="#">click here</a></i>	
<b>Performance Data</b>	Data Table
	Swept Graphs
	S-Parameter (S2P Files) Data Set (.zip file)
<b>Case Style</b>	MMM1362 (SOT 343) <i>Plastic package, exposed paddle</i> <i>Lead finish: Matte-Tin</i>
<b>Tape &amp; Reel</b> Standard quantities available on reel	F90 <i>7" reels with 20, 50, 100, 200, 500, 1K, 2K or 3K devices</i>
<b>Suggested Layout for PCB Design</b>	PL-684
<b>Evaluation Board</b>	TB-PSA-14+
<b>Environmental Ratings</b>	ENV08T1

**ESD Rating**

Human Body Model (HBM): Class 1C (1000 to <2000V) in accordance with ANSI/ESD STM 5.1 - 2001  
Machine Model (MM): Class M2 (100 to <200V) in accordance with ANSI/ESD STM5.2-1999

**MSL Rating**

Moisture Sensitivity: MSL1 in accordance with IPC/JEDEC J-STD-020D

**MSL Test Flow Chart**

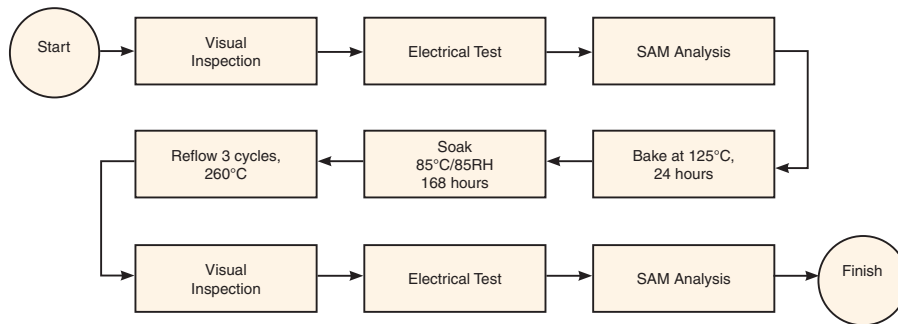

**Additional Notes**

- A. Performance and quality attributes and conditions not expressly stated in this specification document are intended to be excluded and do not form a part of this specification document.
- B. Electrical specifications and performance data contained in this specification document are based on Mini-Circuit's applicable established test performance criteria and measurement instructions.
- C. The parts covered by this specification document are subject to Mini-Circuits standard limited warranty and terms and conditions (collectively, "Standard Terms"); Purchasers of this part are entitled to the rights and benefits contained therein. For a full statement of the Standard Terms and the exclusive rights and remedies thereunder, please visit Mini-Circuits' website at [www.minicircuits.com/MCLStore/terms.jsp](http://www.minicircuits.com/MCLStore/terms.jsp)