

**MK-11C04-G013**

侧拨形式

G-Switch P/N

Switch Height (mm)  
G013=1.3

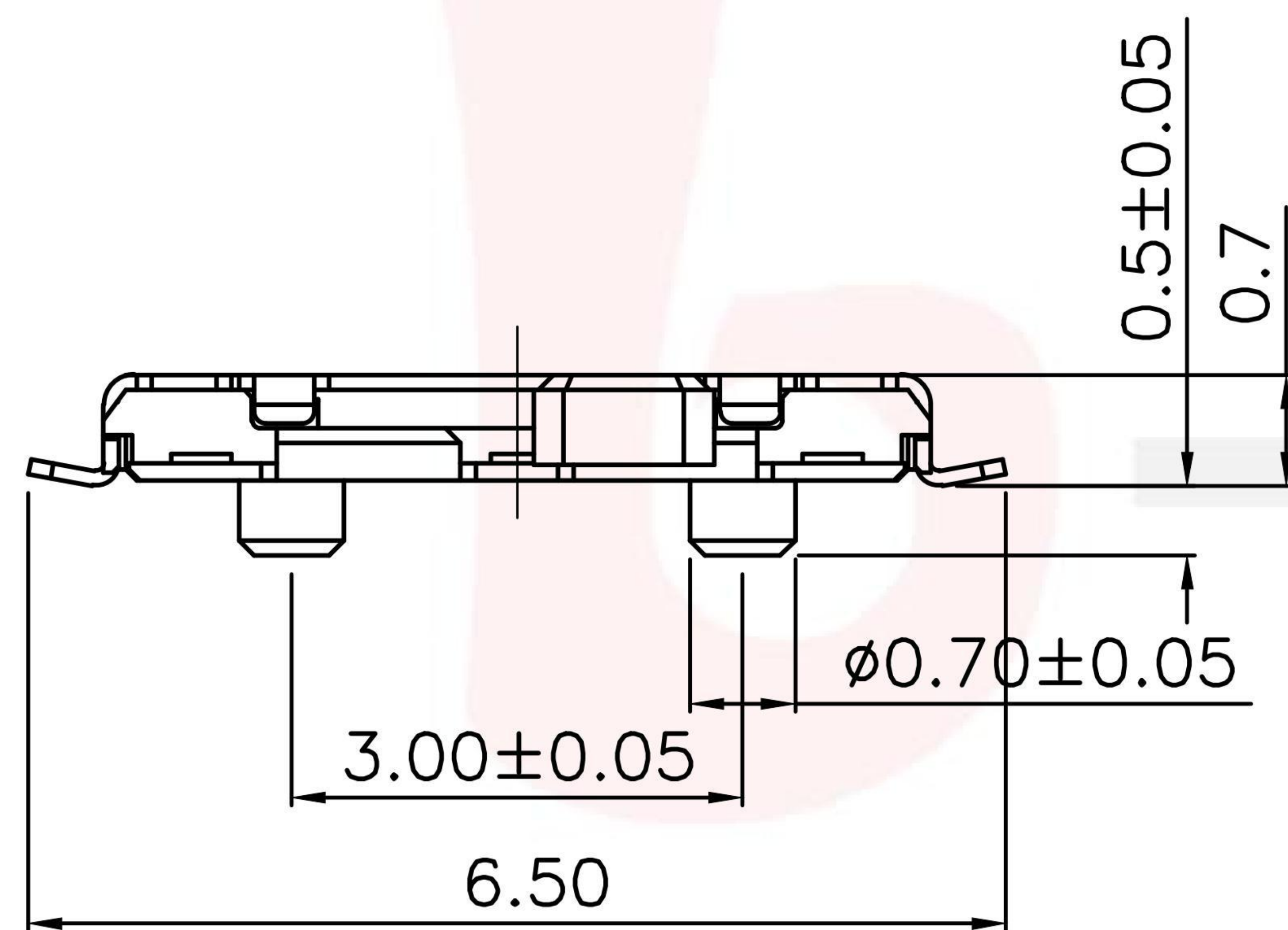

**REFERENCE PATTERN FOR REFLOW SOLDERING**

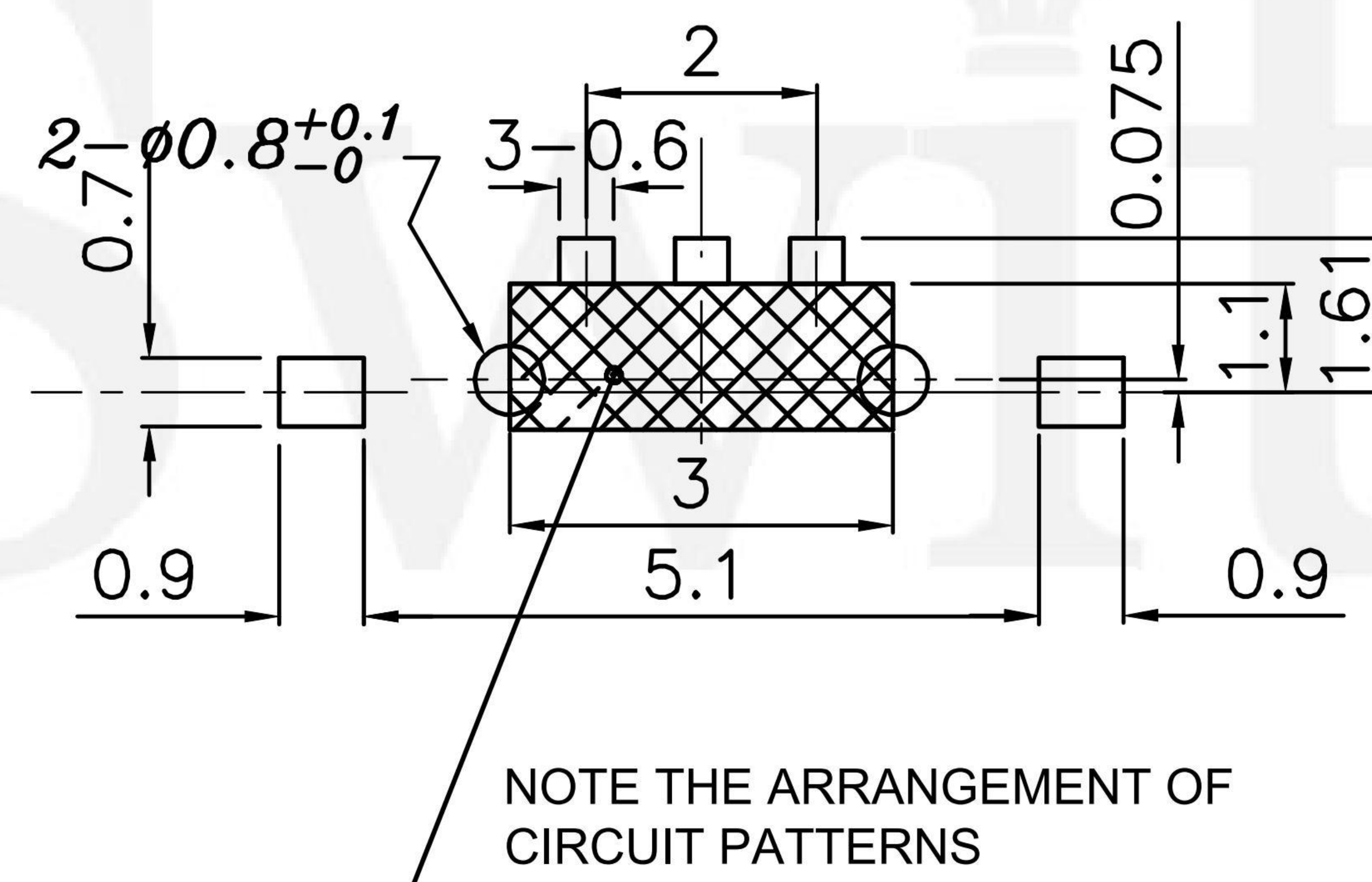

NOTE THE ARRANGEMENT OF CIRCUIT PATTERNS

**G-Switch Specification:**

Electrical Specifications: DC 12V 0.5A DC 6V 1.0A  
 Contact Resistance : 100mΩMAX  
 Insulation Resistance: 100M ohm 100V DC  
 Withstand Voltage: AC 250V for 1 min  
 Ambient Temperature: -20°C~+70°C  
 Relative Humidity: (40°C)≤85%  
 Reflow soldering: 250°C MAX  
 Life: 10,000 times

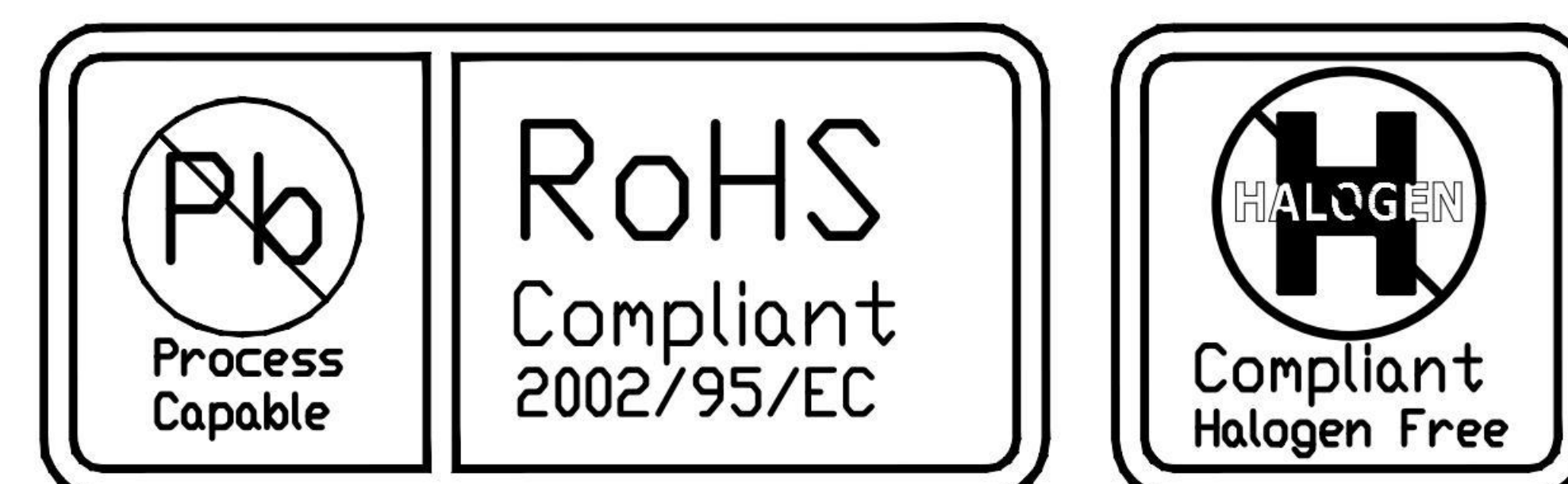
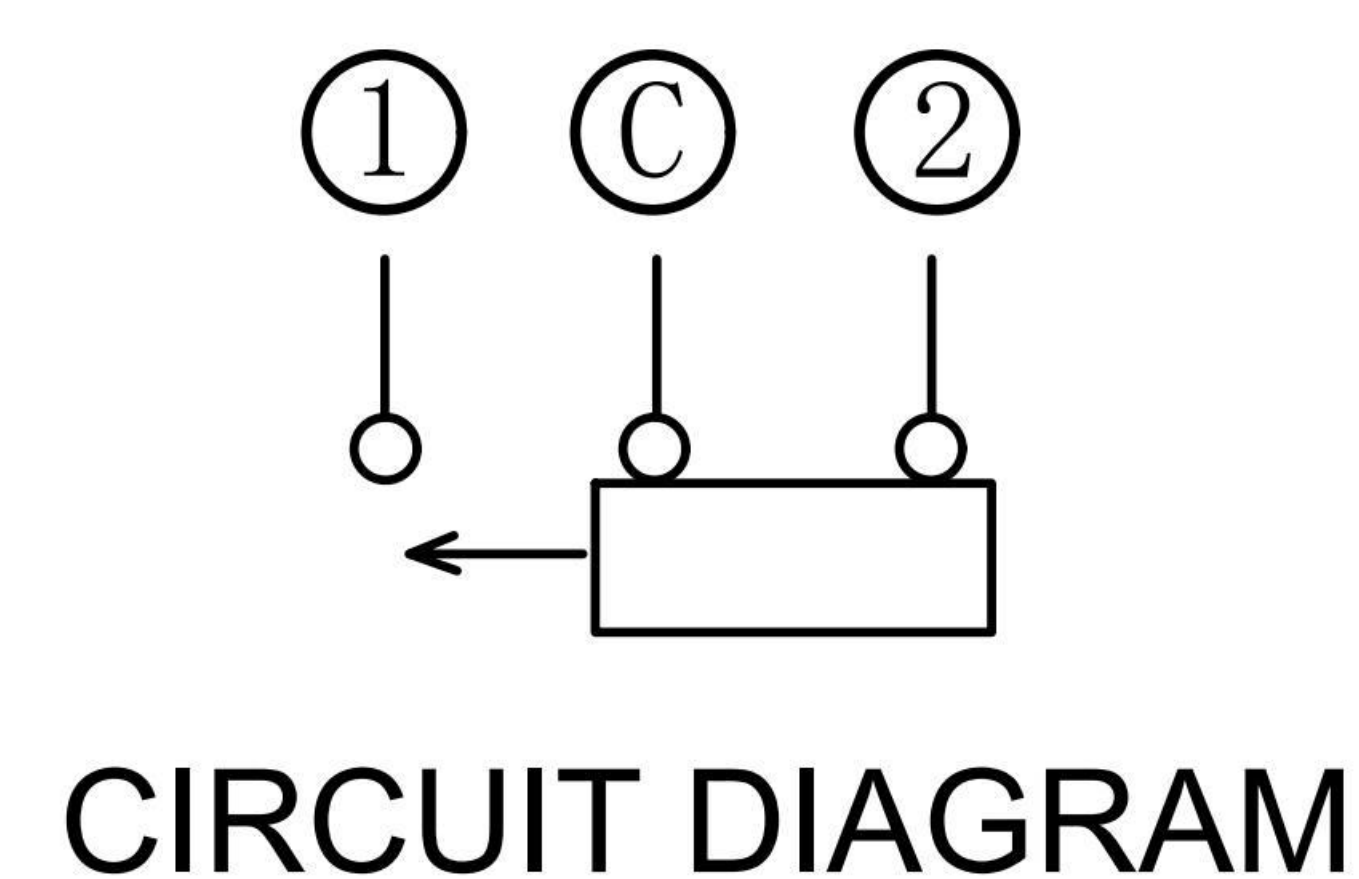

	<b>G-Switch Electronic (HongKong) CO.,Ltd.</b>		
	Unless otherwise specified, Tolerance: X. ±0.30 X.x ±0.20 X.xx ±0.15 X.xxx ±0.10 Angles ±3°	DESIGN FengFengChen CHECKED APPROVED <a href="http://www.dg-switch.com">http://www.dg-switch.com</a> TEL:0769-82388879	DATE 2019.05.29 DATE DATE REV.: X1 SCALE: 4:1 SHEET: 1/1