



SPE0581

Ultra Low Capacitance 4 -Line ESD Protection Array

DESCRIPTION

The SPE0581 is 4-channel very low capacitance ESD transient voltage suppressor which provides a very high level of protection for sensitive electronic components that may be subjected to electrostatic discharge. It is particularly well-suited to protect systems with high speed communication lines from ESD, EFT, and lightning.

The SPE0581 consists of eight low capacitance steering diodes and a TVS diode in a SLP package. Each channel of SPE0581 could safely dissipate ESD strikes of $\pm 15\text{KV}$ air discharge as well as $\pm 8\text{KV}$ contact discharge, meeting the requirement of the IEC 61000-4-2 international standard. Using the MIL-STD-883 (Method 3015) specification for Human Body Model (HBM) ESD, the device provides protection for contact discharges to greater than $\pm 15\text{KV}$.

FEATURES

- ◆ Transient protection for data lines to

IEC 61000-4-2 (ESD)
 $\pm 15\text{kV}$ (air)
 $\pm 8\text{kV}$ (contact)

IEC 61000-4-4 (EFT)
 40A (5/50ns)

- ◆ Protects five bidirectional I/O lines
- ◆ Working voltage: 5V
- ◆ Low leakage current
- ◆ Low operating and clamping voltages
- ◆ Low capacitance: 0.35 pF typical

APPLICATIONS

- ◆ Cellular Handsets and Accessories
- ◆ Cordless Phone
- ◆ PDA
- ◆ Notebooks and Handhelds
- ◆ Portable Instrumentation
- ◆ Digital Cameras
- ◆ MP3 Player High Definition Multi-Media Interface Protection
- ◆ USB 2.0 Power and Data Line
- ◆ Monitors and Notebook Computers
- ◆ HDSL, IDSL Secondary IC Side Protection
- ◆ 10/100/1000 Ethernet

PIN CONFIGURATION (DFN-10)

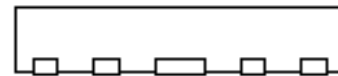

(Length = 2.5mm)

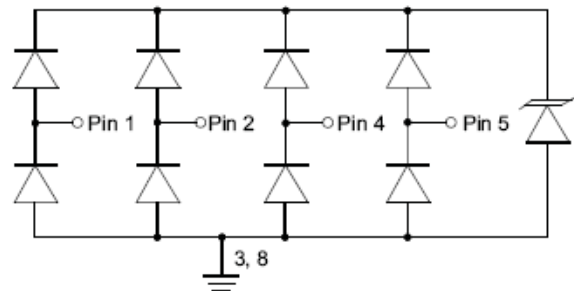

PART MARKING

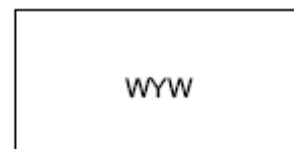

W=Specific Device Code

YW =Date Code (y=year,w=week)



SPE0581

Ultra Low Capacitance 4-Line ESD Protection Array

ORDERING INFORMATION

Part Number	Package	Part Marking
SPE0581DFN10RGB	DFN-10	WYW

※ SPE0581DFN10RGB : Tape Reel ; Pb – Free ; Halogen - Free

ABSOLUTE MAXIMUM RATINGS

(TA=25°C Unless otherwise noted)

Parameter	Symbol	Typical	Unit
Peak Pulse Power (tp = 8/20 μs)	Ppk	180	W
Maximum Peak Pulse Current (tp = 8/20 μs)	Ipp	7	A
ESD per IEC 61000 – 4 – 2 (Air)	Vpp	±15	KV
ESD per IEC 61000 – 4 – 2 (Contact)	Vpp	±8	KV
Operating Junction Temperature	Tj	-55 ~ 125	°C
Storage Temperature Range	TSTG	-55 ~ 150	°C
Lead Soldering Temperature	TL	260 (10sec)	°C

ELECTRICAL CHARACTERISTICS

(TA=25°C Unless otherwise noted)

Parameter	Symbol	Conditions	Min.	Typ	Max.	Unit
Reverse Stand – Off Voltage	VRWM				5	V
Forward Voltage @ IF	VF	IF = 10mA	0.4	0.8	1.5	V
Reverse Breakdown Voltage	VBR	It = 1mA	6.0	7.0		V
Reverse Leakage Current	IR	VRWM = 5V , T=25°C		0.01	1	μA
Clamping Voltage	VC	Ipp = 1A , tp = 8/20 μs			12	V
Junction Capacitance	Cj	VR = 0V, f = 1MHz Any I/O pin to Ground		0.7	1.0	pF
		VR = 0V, f = 1MHz Between I/O pins		0.35		



SPE0581

Ultra Low Capacitance 4-Line ESD Protection Array

TYPICAL CHARACTERISTICS

Non-Repetitive Peak Pulse Power vs. Pulse Time

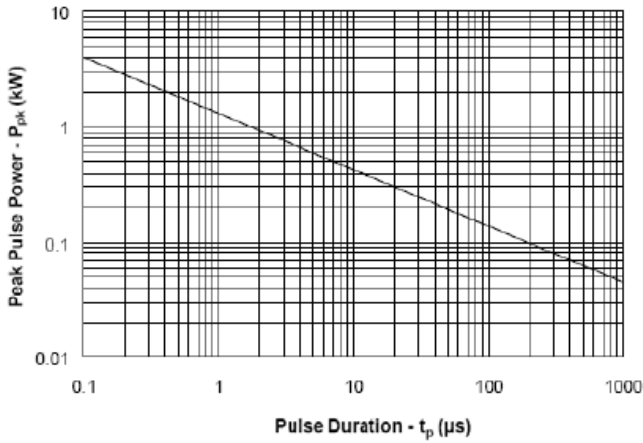

Power Derating Curve

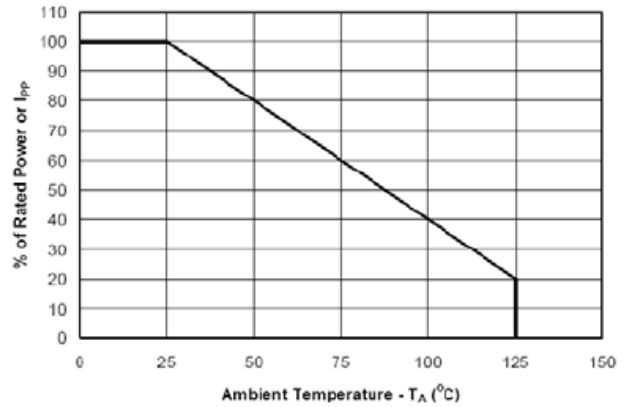

Clamping Voltage vs. Peak Pulse Current

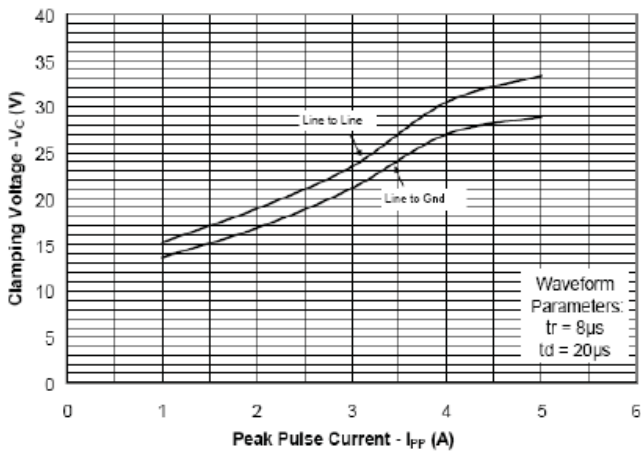

Forward Voltage vs. Forward Current

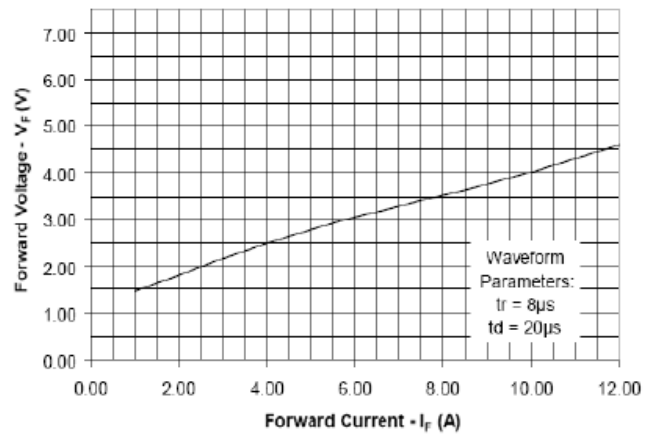



SPE0581

Ultra Low Capacitance 4 -Line ESD Protection Array

SCHEMATIC & PIN CONFIGURATION

As Figure Shown is an example of how to route the high speed differential traces through the SPE0581. The solid line represents the PCB trace. The PCB traces are used to connect the pin pairs for each line (pin 1 to pin 10, pin 2 to pin 9, pin 4 to pin 7, pin 5 to pin 6). For example, line 1 enters at pin 1 and exits at Pin 10 and the PCB trace connects pin 1 and 10 together. This is true for lines connected at pins 2, 4, and 5 also. Ground is connected at pins 3 and 8. One large ground pad should be used in lieu of two separate pads.

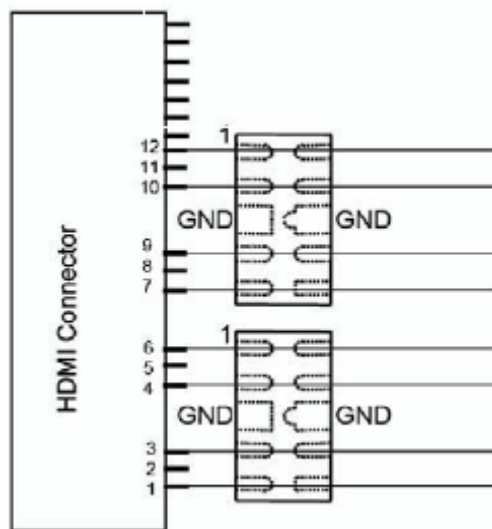

Flow through Layout Using SPE6V8UD

APPLICATION INFORMATION (Design Recommendations for HDMI Protection)

Adding external ESD protection to HDMI ports can be challenging. First, ESD protection devices have an inherent junction capacitance. However, adding even a small amount of capacitance will cause the impedance of the differential pair to drop. Second, large packages and land pattern requirements cause discontinuities that adversely affect signal integrity. The SPE0581 is specifically designed for protection of high-speed interfaces such as HDMI. They present $<0.4\text{pF}$ capacitance between the pairs while being rated to handle $\pm 8\text{KV}$ ESD contact discharges (15KVair discharge) as outlined in IEC61000-4-2. Each device is in a leadless DFN package that is less than 1.1mm wide. They are designed such that the traces flow straight through the device. The narrow package and flow-through design reduces discontinuities and minimizes impact on signal integrity. This becomes even more critical as signal speeds increase.



SPE0581

Ultra Low Capacitance 4-Line ESD Protection Array

DFN-10 PACKAGE OUTLINE

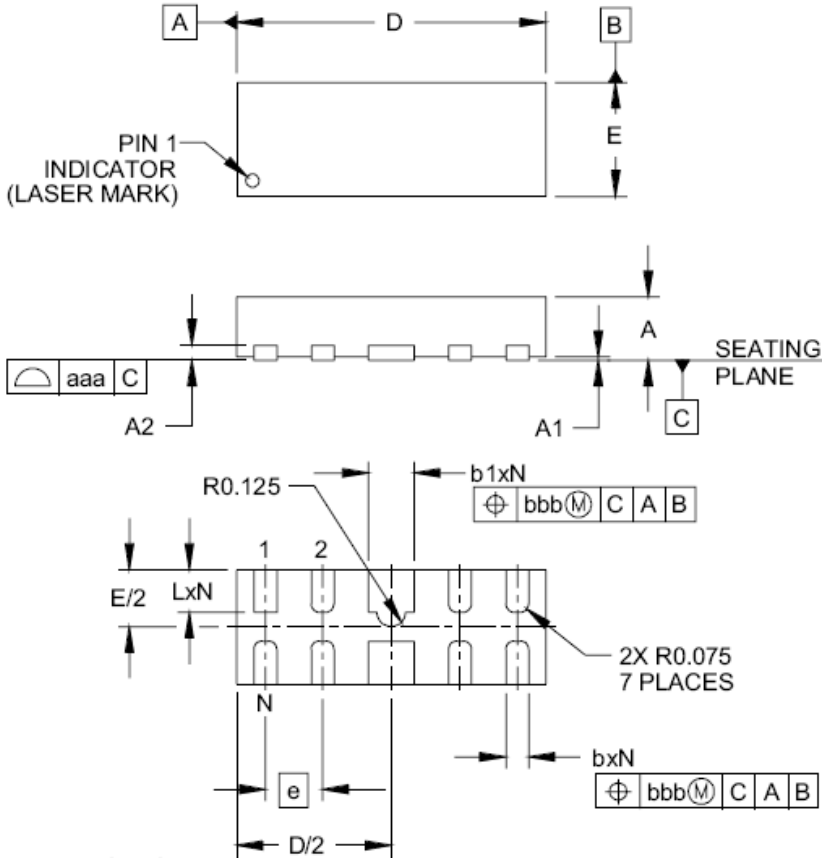

DIM	INCHES			MILLIMETERS		
	MIN	NOM	MAX	MIN	NOM	MAX
A	.020	.023	.026	0.50	0.58	0.65
A1	0.00	.001	.002	0.00	0.03	0.05
A2	(.005)			(0.13)		
b	.006	.008	.010	0.15	0.20	0.25
b1	.014	.016	.018	0.35	0.40	0.45
D	.094	.098	.102	2.40	2.50	2.60
E	.035	.039	.043	0.90	1.00	1.10
e	.020 BSC			0.50 BSC		
L	.012	.015	.017	0.30	0.38	0.425
N	10			10		
aaa	.003			0.08		
bbb	.004			0.10		

NOTES:

1. CONTROLLING DIMENSIONS ARE IN MILLIMETERS (ANGLES IN DEGREES).

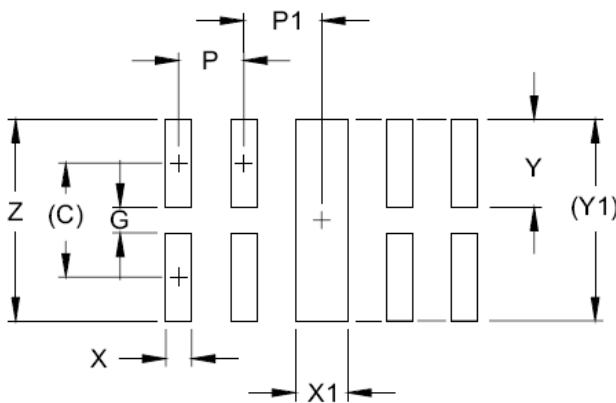

DIM	DIMENSIONS	
	INCHES	MILLIMETERS
C	(.034)	(0.875)
G	.008	0.20
P	.020	0.50
P1	.020	0.50
X	.008	0.20
X1	.016	0.40
Y	.027	0.675
Y1	(.061)	(1.55)
Z	.061	1.55

NOTES:

1. CONTROLLING DIMENSIONS ARE IN MILLIMETERS (ANGLES IN DEGREES).
2. THIS LAND PATTERN IS FOR REFERENCE PURPOSES ONLY. CONSULT YOUR MANUFACTURING GROUP TO ENSURE YOUR COMPANY'S MANUFACTURING GUIDELINES ARE MET.



SPE0581

Ultra Low Capacitance 4 -Line ESD Protection Array

Information provided is alleged to be exact and consistent. SYNC Power Corporation presumes no responsibility for the penalties of use of such information or for any violation of patents or other rights of third parties which may result from its use. No license is granted by allegation or otherwise under any patent or patent rights of SYNC Power Corporation. Conditions mentioned in this publication are subject to change without notice. This publication surpasses and replaces all information previously supplied. SYNC Power Corporation products are not authorized for use as critical components in life support devices or systems without express written approval of SYNC Power Corporation.

©The SYNC Power logo is a registered trademark of SYNC Power Corporation

©2004 SYNC Power Corporation – Printed in Taiwan – All Rights Reserved

SYNC Power Corporation

7F-2, No.3-1, Park Street

NanKang District (NKSP), Taipei, Taiwan, 115, R.O.C

Phone: 886-2-2655-8178

Fax: 886-2-2655-8468

©<http://www.syncpower.com>