

CATALOG NUMBER	A	B	C	D	E
MRA9P	1.31	1.000	.38	.070	.062
MRA14P	1.25	.937	.44	.070	.062
MRA20P	1.56	1.250	.44	.070	.062
MRA34P	2.00	1.688	.75	.070	.062
MRA41P	2.62	2.312	.44	.070	.062
MRA42P	2.31	2.000	.75	.070	.062
MRA50P	2.59	2.282	.75	.070	.062
MRA50-8P	2.28	1.969	1.13	.070;.106	.062;.094
MRA66P	2.28	1.969	1.13	.070	.062
MRA75P	2.59	2.282	1.11	.070	.062
MRA104P	2.75	2.375	1.53	.070	.062

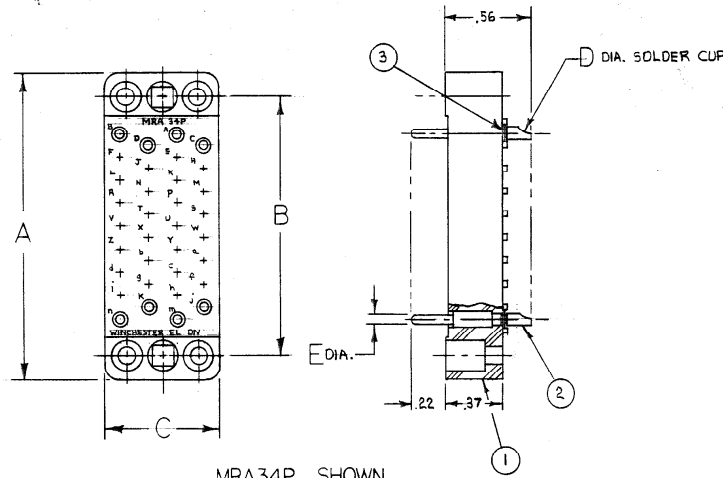

MRA34P SHOWN

- ① MOLDING, MALE - DIALLYL PHTHALATE, TYPE MDG, MIL-M-14F, MIL-P-4389
(SIZES 50-8 AND 66: DIALLYL PHTHALATE PER MIL-M-14, TYPE SDG-F)
- ② CONTACT, PIN - BRASS PER QQ-B-626; GOLD OVER COPPER.
- ③ CLIP SPRING - PHOSPHOR BRONZE PER QQ-B-750, GOLD OVER COPPER.

FACES OF THE "MRA" MOLDINGS

MALE CONTACTS NO. 9 THRU 104

19374 B

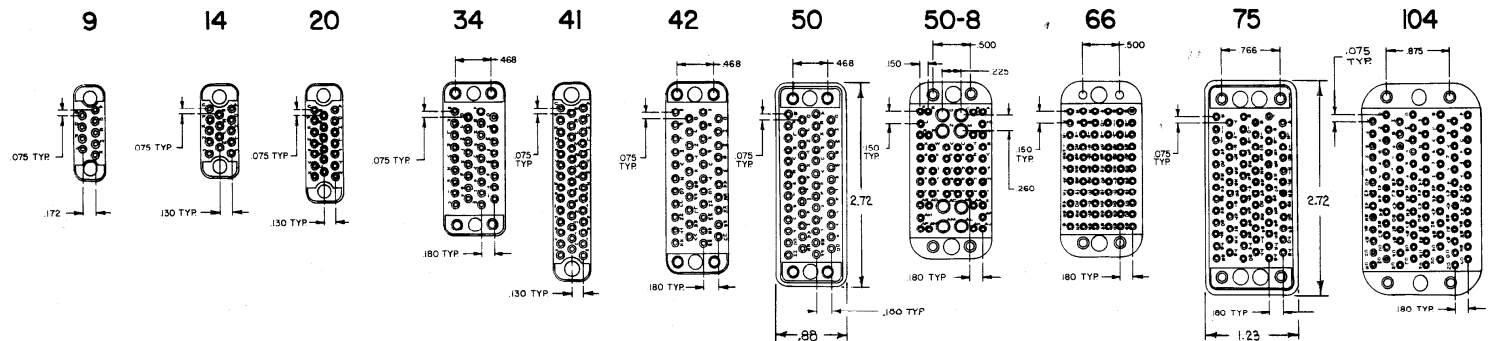

TOLERANCE UNLESS OTHERWISE SPECIFIED .XX = .02 .XXX = .007 ANGULAR =

REV	CHANGE	DATE
A	REDRAWN (UPDATED) EVALUATED EVALUATED	9-27-77
B	ITEM 1 WAS MIN. FILLED SOLDER ANNEAL SOLDER	3-28-80

COMPOSITE OUTLINE ASS'Y.
MRA**P

SCALE: 2:1 DWG. NO. 6.A DATE 4-3-61 CRP. F. PLATT DATE 4-3-61

WINCHESTER ELECTRONICS
CAMVILLE, CONN.

DWG. NO. 19374