

DASH NO.	M CODE	MADE FROM
----------	--------	-----------

GSD

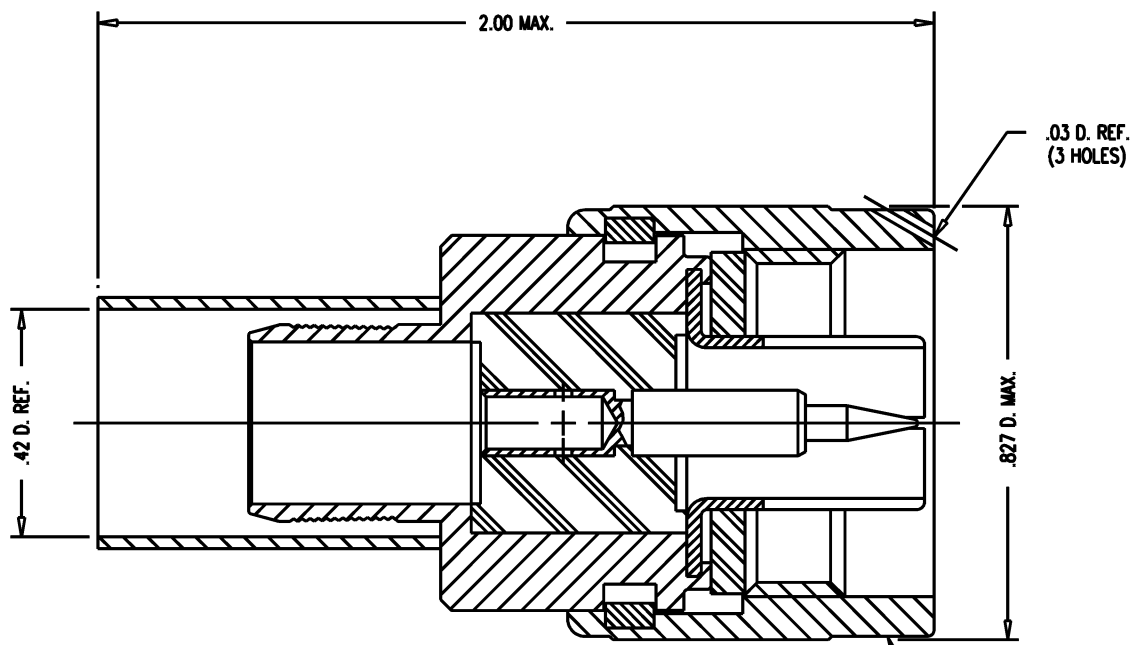

STAMP: 91836 M39012/01-0017
1205-68-5 YRWK (DATE CODE)

- NOTES:
- FOR USE WITH M17/74-213 CABLE.
 - FOR CABLING INSTRUCTIONS SEE 3-610.
 - FOR CABLE TRIMMING USE KTJ-137 & KTD-138.
 - FOR CRIMPING USE DIE KTH-2004.
 - INTERFACE PER MIL-STD-348, FIG. 304-1.
 - CENTER CONTACT SUPPLIED UNASSEMBLED.
 - MATERIALS:
INSULATOR: TEFLON, ASTM-D-4894
GASKETS: SILICONE RUBBER, ZZ-R-765
K-GRIP SLEEVE: COM. BRONZE TUBE, ASTM-B-140
C-RING }
OUTER CONTACT } PHOSPHOR BRONZE, ASTM-B-103
ALL OTHER METAL PARTS: BRASS, ASTM-B16
 - FINISHES:
CENTER CONTACT: HARD GOLD PLATE PER MIL-G-45204
ALL OTHER METAL PARTS: SILVER PLATE PER QQ-S-365
 - ELECTRICAL CHARACTERISTICS:
NOMINAL IMPEDANCE: 50 OHMS
WORKING VOLTAGE: 1000 VRMS
FREQUENCY RANGE: DC TO 11 GHz.

M39012/01-0017

REVISIONS	
ISSUE	CHANGES
0	ER 36057 MJB 01/18/95
1	CN 36099 E ME 02/09/95
2	CN 38571 E TML 05/21/02

MJB2547

SCALE	4:1
APPROX SURFACE AREA	1205-68-5
USED ON	
REF:	PL, N
DRAWN	MJB 12/02/94
DESIGN	LI 12/02/94
APPR.	LI 02/24/95
KINGS ELECTRONICS CO., INC. ROCK HILL, SOUTH CAROLINA 29730	
M39012/01-0017	

GSD