

QAE100 SERIES

QUARTER-BRICK DC-DC CONVERTER

2:1 ULTRA WIDE INPUT RANGE
UP TO 108Watts

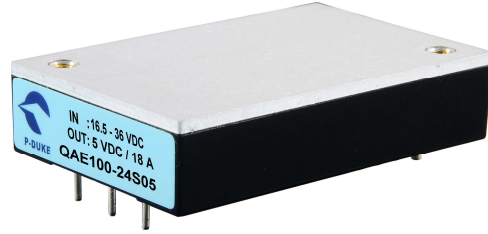

FEATURES

- NO MINIMUM LOAD REQUIRED
- LOW STANDBY POWER CONSUMPTION
- 2250VDC INPUT TO OUTPUT BASIC INSULATION
- SAFETY MEETS UL60950-1, EN60950-1, & IEC60950-1
- CE MARKED
- COMPLIANT TO RoHS II & REACH

APPLICATIONS

- WIRELESS NETWORK
- TELECOM/DATACOM
- INDUSTRY CONTROL SYSTEM
- DISTRIBUTED POWER ARCHITECTURES
- SEMICONDUCTOR EQUIPMENT

2250VDC ISOLATION	REMOTE CONTROL	UVP	OCP	SCP	OVP	OTP	LOW STANDBY POWER
-------------------	----------------	-----	-----	-----	-----	-----	-------------------

TECHNICAL SPECIFICATION

All specifications are typical at nominal input, full load and 25°C otherwise noted

Model Number	Input Range	Output Voltage	Output Current @Full Load	Input Current @ No Load	Efficiency	Maximum Capacitor Load
	VDC	VDC	A	mA	%	µF
QAE100-12S3P3	8.5 ~ 22	3.3	25	50	89	75000
QAE100-12S05	8.5 ~ 22	5	18	50	90	36000
QAE100-12S12	8.5 ~ 22	12	7.5	50	91	6250
QAE100-12S15	8.5 ~ 22	15	6	50	91	4000
QAE100-12S24	8.5 ~ 22	24	3.7	50	90	1540
QAE100-12S30	8.5 ~ 22	30	3	50	90	1000
QAE100-12S48	8.5 ~ 22	48	1.8	50	89	380
QAE100-24S3P3	16.5 ~ 36	3.3	25	25	89	75000
QAE100-24S05	16.5 ~ 36	5	18	25	90	36000
QAE100-24S12	16.5 ~ 36	12	7.5	25	91	6250
QAE100-24S15	16.5 ~ 36	15	6	25	91	4000
QAE100-24S24	16.5 ~ 36	24	3.7	25	92	1540
QAE100-24S30	16.5 ~ 36	30	3	25	91	1000
QAE100-24S48	16.5 ~ 36	48	1.8	25	89	380
QAE100-48S3P3	33 ~ 75	3.3	25	15	89	75000
QAE100-48S05	33 ~ 75	5	21	15	91	42000
QAE100-48S12	33 ~ 75	12	9	15	90	7500
QAE100-48S15	33 ~ 75	15	7	15	91	4600
QAE100-48S24	33 ~ 75	24	4.5	15	93	1870
QAE100-48S30	33 ~ 75	30	3.5	15	92	1160
QAE100-48S48	33 ~ 75	48	2.2	15	91	460

PART NUMBER STRUCTURE

QAE100	-	48	S	05	-	P	HS
Series Name		Input Voltage (VDC)	Output Quantity	Output Voltage (VDC)		Ctrl and Pin Options	Heat-sink and Mounting Hole Tread Options
		12:8.5~22 24:16.5~36 48:33~75	S:Single	3P3:3.3 05:5 12:12 15:15 24:24 30:30 48:48		□:Negative logic P:Positive logic	□:NC HS:H=0.24" Horizontal, 7G-0029A-F HS1:H=0.5" Horizontal, 7G-0030A-F HS2:H=0.24" Vertical, 7G-0031A-F HS3:H=0.5" Vertical, 7G-0032A-F TH:Through hole (No thread) ⁽¹⁾

(1) The module can't equip Heat-sink with TH option.

INPUT SPECIFICATIONS

Parameter	Conditions		Min.	Typ.	Max.	Unit
Operating input voltage range		12Vin(nom)	8.5	12	22	VDC
		24Vin(nom)	16.5	24	36	
		48Vin(nom)	33	48	75	
Start-up voltage		12Vin(nom)			9	VDC
		24Vin(nom)			18	
		48Vin(nom)			36	
Shutdown voltage		12Vin(nom)	7.3		8.1	VDC
		24Vin(nom)	15.5		16.3	
		48Vin(nom)	31.6		32.5	
Start up time	Constant resistive load	Power up		75	100	ms
		Remote ON/OFF		75	100	
Input surge voltage	1 second, max.	12Vin(nom)			30	VDC
		24Vin(nom)			50	
		48Vin(nom)			100	
Input filter ⁽¹⁾				Pi type		
Remote ON/OFF	Referred to -Vin pin	Negative logic (Standard)	DC-DC ON		Short or 0 ~ 1.2 VDC	
			DC-DC OFF		Open or 3 ~ 12 VDC	
		Positive logic (Option)	DC-DC ON		Open or 3 ~ 12 VDC	
			DC-DC OFF		Short or 0 ~ 1.2 VDC	
		Input current of Ctrl pin		-0.5	1	mA
		Remote off input current			3	mA

OUTPUT SPECIFICATIONS

Parameter	Conditions		Min.	Typ.	Max.	Unit
Voltage accuracy			-1.0		+1.0	%
Line regulation	Low Line to High Line at Full Load		-0.1		+0.1	%
Load regulation	No Load to Full Load	3.3 & 5Vout	-0.2		+0.2	%
		Others	-0.1		+0.1	
Voltage adjustability	Maximum output deviation is inclusive of remote sense		-20		+10	%
Remote sense	% of Vout(nom). If remote sense is not being used, sense pins should connect to the output pins with the same polarity.				10	%
Ripple and noise	Measured by 20MHz bandwidth					mVp-p
	With a 22µF/25V X7R MLCC	3.3Vout, 5Vout		75		
	With a 22µF/25V X7R MLCC	12Vout, 15Vout		100		
	With a 4.7µF/50V X7R MLCC	24Vout, 30Vout		200		
	With a 2.2µF/100V X7R MLCC	48Vout		300		
Temperature coefficient			-0.02		+0.02	%/°C
Transient response recovery time	25% load step change			250		µs
Over voltage protection	% of Vout(nom); Hiccup mode		115		130	%
Over load protection	% of Iout rated; Hiccup mode		110		140	%
Short circuit protection			Continuous, automatic recovery			

GENERAL SPECIFICATIONS

Parameter	Conditions		Min.	Typ.	Max.	Unit
Isolation voltage	1 minute (Basic insulation)	Input to Output	2250			VDC
		Input (Output) to Base-Plate	2250			
Isolation resistance	500VDC		1			GΩ
Isolation capacitance					1500	pF
Switching frequency			270	300	330	kHz
Safety meets			UL60950-1 EN60950-1 IEC60950-1			
Case material			Aluminum base-plate with plastic case			
Potting material			Silicone (UL94 V-0)			
Weight			64g (2.26oz)			
MTBF	MIL-HDBK-217F, Full load		3.873 x 10 ⁵ hrs			

ENVIRONMENTAL SPECIFICATIONS

Parameter	Conditions	Min.	Typ.	Max.	Unit
Operating base-plate temperature		-40		+100	°C
Over temperature protection			+110		°C
Storage temperature range		-55		+125	°C
Thermal impedance (2)	Vertical direction by natural convection (20LFM)		9		°C/W
	Mount on 2U iron base-plate		2.8		
	With 0.24" Height Heat-sink		7.1		
	With 0.5" Height Heat-sink		5.5		
Thermal shock					MIL-STD-810F
Vibration					MIL-STD-810F
Relative humidity					5% to 95% RH

EMC SPECIFICATIONS

Parameter	Conditions	Level
EMI (3)	EN55022	Class A Class B
ESD	EN61000-4-2 Air ± 8kV Contact ± 6kV	Perf. Criteria A
Radiated immunity	EN61000-4-3 20 V/m	Perf. Criteria A
Fast transient (4)	EN61000-4-4 ± 2kV	Perf. Criteria A
Surge (4)	EN61000-4-5 EN55024:±2kV	Perf. Criteria A
Conducted immunity	EN61000-4-6 10 Vr.m.s	Perf. Criteria A

Note:

- Input source impedance: The power modules will operate as specifications without external components, assuming that the source voltage has a very low impedance and reasonable input voltage regulation. Highly inductive source impedances can affect the stability of the power module. Since real-world voltage source has finite impedance, performance can be improved by adding external filter capacitor. Recommended Nippon Chemi-con KY series, 100µF/100V.
- The heat-sink is optional and P/N: 7G-0029A-F, 7G-0030A-F, 7G-0031A-F, 7G-0032A-F. Please refer to heat-sink selection guide.
- The standard modules meet EMI Class A or Class B with external components. For further information, please contact with P-DUKE.
- An external input filter capacitor is required if the module has to meet EN61000-4-4, EN61000-4-5. Recommended 2 pcs of aluminum electrolytic capacitor (Nippon chemi-con KY series, 220µF/100V) to connect in parallel.
- BASE-PLATE GROUNDING: When connect two screw bolts to shield plane, the EMI could be reduced.

CAUTION: This power module is not internally fused. An input line fuse must always be used.

CHARACTERISTIC CURVE

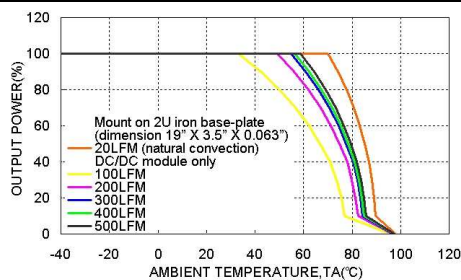

QAE100-48S05 Derating Curve

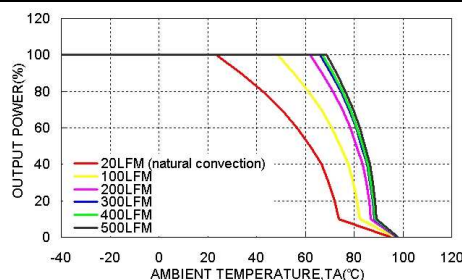

QAE100-48S05 Derating Curve With 0.24" Height Heat-sink

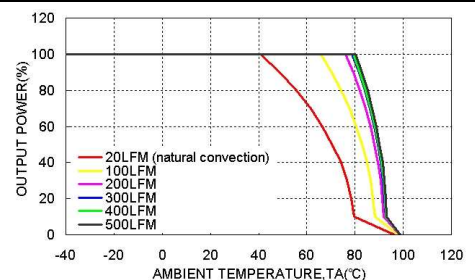

QAE100-48S05 Derating Curve With 0.5" Height Heat-sink

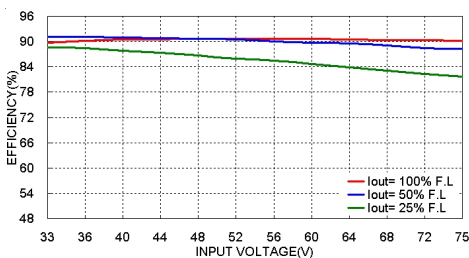

QAE100-48S05 Efficiency vs. Input Voltage

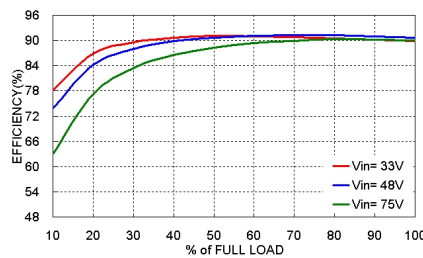

QAE100-48S05 Efficiency vs. Output Load

MECHANICAL DRAWING

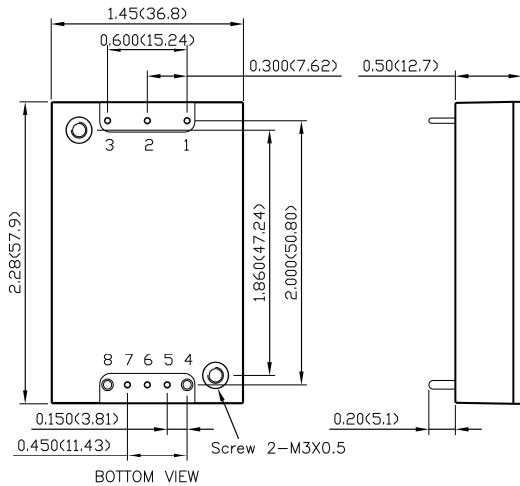

PIN CONNECTION

PIN	DEFINE	DIAMETER
1	- Vin	0.04 Inch
2	Ctrl	0.04 Inch
3	+ Vin	0.04 Inch
4	- Vout	0.06 Inch
5	- Sense	0.04 Inch
6	Trim	0.04 Inch
7	+ Sense	0.04 Inch
8	+ Vout	0.06 Inch

EXTERNAL OUTPUT TRIMMING

Output can be externally trimmed by using the method shown below.

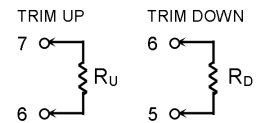

1. All dimensions in inch (mm)
2. Tolerance :x.xx±0.02 (x.x±0.5)
x.xxx±0.01 (x.xx±0.25)
3. Pin pitch tolerance ±0.01 (0.25)
4. Pin dimension tolerance ±0.004(0.1)
5. The screw locked torque:
MAX 3.5kgf-cm (0.34N-m)

$$R_U = \left(\frac{5.11V_{OUT}(100 + \Delta\%)}{1.225\Delta\%} - \frac{(511 + 10.22\Delta\%)}{\Delta\%} \right) k\Omega$$

$$R_D = \left(\frac{511}{\Delta\%} - 10.22 \right) k\Omega$$

HEAT-SINK TYPE OPTIONS

7G-0029A-F

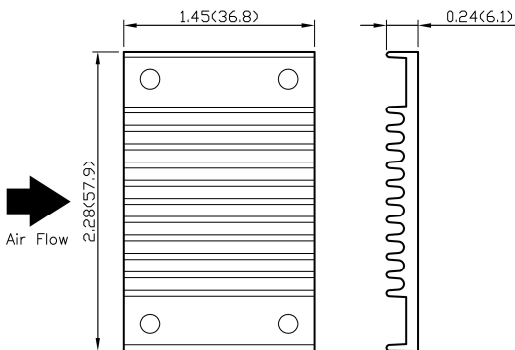

7G-0030A-F

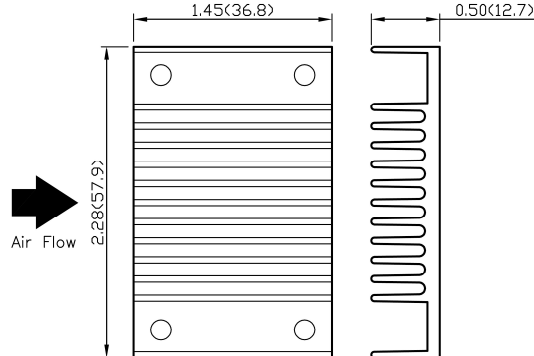

7G-0031A-F

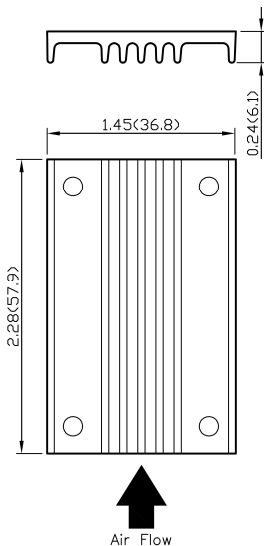

7G-0032A-F

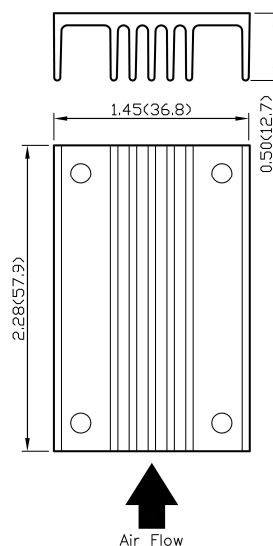

1. All dimensions in inch (mm)
2. Tolerance :x.xx±0.02 (x.x±0.5)