

isc N-Channel MOSFET Transistor

2SK1569

DESCRIPTION

- Drain Current $-I_D=8A @ T_C=25^\circ C$
- Drain Source Voltage-
: $V_{DSS}=300V(\text{Min})$

APPLICATIONS

- Desinged for high efficiency switch mode power supply.

ABSOLUTE MAXIMUM RATINGS($T_a=25^\circ C$)

SYMBOL	ARAMETER	VALUE	UNIT
V_{DSS}	Drain-Source Voltage ($V_{GS}=0$)	300	V
V_{GS}	Gate-Source Voltage	± 20	V
I_D	Drain Current-continuous@ $T_C=25^\circ C$	8	A
P_{tot}	Total Dissipation@ $T_C=25^\circ C$	40	W
T_j	Max. Operating Junction Temperature	150	$^\circ C$
T_{stg}	Storage Temperature Range	-55~150	$^\circ C$

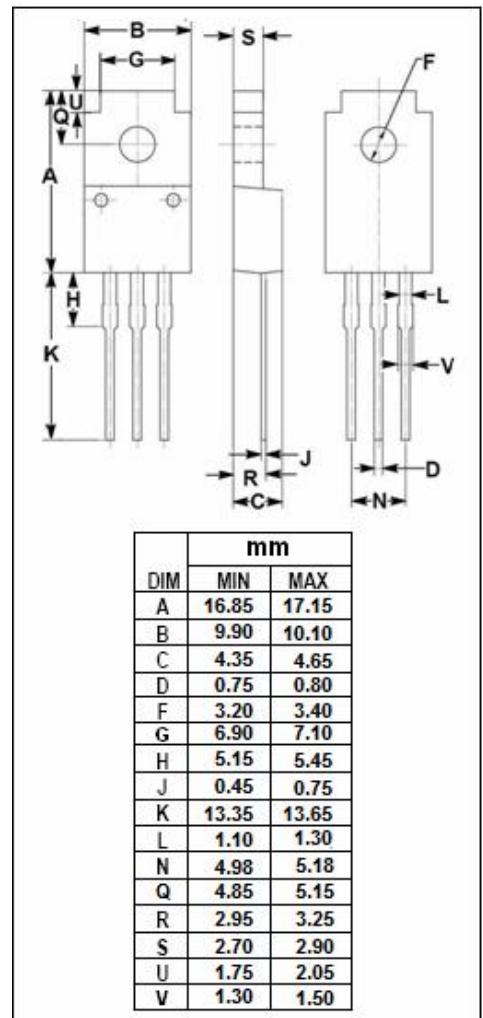
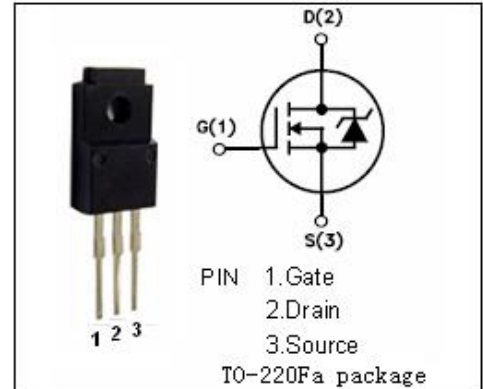

isc N-Channel Mosfet Transistor**2SK1569****• ELECTRICAL CHARACTERISTICS (T_C=25°C)**

SYMBOL	PARAMETER	CONDITIONS	MIN	TYP	MAX	UNIT
V _{(BR)DSS}	Drain-Source Breakdown Voltage	V _{GS} =0; I _D = 1mA	300			V
V _{GS(th)}	Gate Threshold Voltage	V _{DS} =25V; I _D =1mA	2.0	3.0	4.0	V
R _{DS(on)}	Drain-Source On-stage Resistance	V _{GS} =10V; I _D =4A			0.65	Ω
I _{GSS}	Gate Source Leakage Current	V _{GS} = ±20V; V _{DS} = 0			± 100	nA
I _{DSS}	Zero Gate Voltage Drain Current	V _{DS} =300V; V _{GS} = 0			300	uA