

Plug-in Signal Conditioners M-UNIT

DC ALARM

(front control button adjustment)

Functions & Features

- Providing SPDT relay outputs at preset DC input levels
- Dual trip
- Latching or non-latching output
- Deadband, ON-delay, Hi/Lo trip, failsafe action can be programmed with front UP/DOWN control buttons
- Enclosed relays
- High-density mounting

Typical Applications

- Annunciator
- Various alarm applications

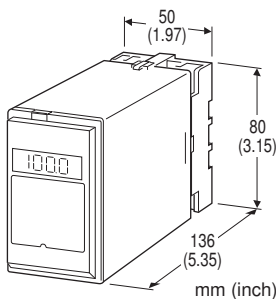

MODEL: MSEF-[1]5-[2][3]

ORDERING INFORMATION

- Code number: MSEF-[1]5-[2][3]
- Specify a code from below for each of [1] through [3].
(e.g. MSEF-65-F/UL/Q)
- Specify the specification for option code /Q
(e.g. /C01)

[1] INPUT

Current

- A: 4 - 20 mA DC (Input resistance 250 Ω)
- B: 2 - 10 mA DC (Input resistance 500 Ω)
- C: 1 - 5 mA DC (Input resistance 1000 Ω)

Voltage

- 4: 0 - 10 V DC (Input resistance 1 MΩ min.)
- 5: 0 - 5 V DC (Input resistance 1 MΩ min.)
- 6: 1 - 5 V DC (Input resistance 1 MΩ min.)

OUTPUT

- 5: Dual trip; SPDT or transfer contact

[2] POWER INPUT

AC Power

- B: 100 V AC
- C: 110 V AC
- D: 115 V AC
- F: 120 V AC
- G: 200 V AC (Option /UL not selectable.)
- H: 220 V AC (Option /UL not selectable.)
- J: 240 V AC (Option /UL not selectable.)

DC Power

- R: 24 V DC (Option /UL not selectable.)
- S: 12 V DC (Option /UL not selectable.)

[3] OPTIONS (multiple selections)

Standards & Approvals

- blank: CE marking
- /UL: UL approval, CE marking

Other Options

- blank: none
- /Q: Option other than the above (specify the specification)

SPECIFICATIONS OF OPTION: Q (multiple selections)

COATING (For the detail, refer to M-System's web site.)

- /C01: Silicone coating
- /C02: Polyurethane coating
- /C03: Rubber coating (UL not available)

TERMINAL SCREW MATERIAL

- /S01: Stainless steel (UL not available)

GENERAL SPECIFICATIONS

Construction: Plug-in

Connection: M3.5 screw terminals

Screw terminal: Chromated steel (standard) or stainless steel

Housing material: Flame-resistant resin (black)

Isolation: Input to output to power

Latching output: Alternatively selectable to deadband option; reset with the power turned OFF.

Front LEDs: Red/green dual-color LED

Run mode: Red turns ON in tripped condition.

L1 for Output 1, L2 for Output 2

Check mode: Green turns ON.

Set mode: Red/green turns ON.

Display: LED, 4-digit digital meter

Display range: -14.0 to +113.5 %

Programming: Front key pad

- Trip point
- Hysteresis (deadband)
- Latching
- Trip operation (Hi/Lo, coil energized/de-energized)
- ON-delay time

- Power ON-delay time
(Refer to the instruction manual)

to power to ground)

INPUT SPECIFICATIONS

■ DC Current:

Shunt resistor attached to the input terminals (0.5 W)

OUTPUT SPECIFICATIONS

■ Relay Contact: 100 V AC @ 5 A (cos ϕ = 1)

120 V AC @ 5 A (cos ϕ = 1)

240 V AC @ 2.5 A (cos ϕ = 1)

30 V DC @ 5 A (resistive load)

Maximum switching voltage: 300 V AC or 125 V DC

Maximum switching power: 600 VA or 150 W

Minimum load: 5 V DC @ 10 mA

Mechanical life: 5×10^7 cycles

Alarm Trip Operation

Terminal No. in parentheses

[Example]

Output 1: High trip, coil energized at alarm

Output 2: Low trip, coil energized at alarm

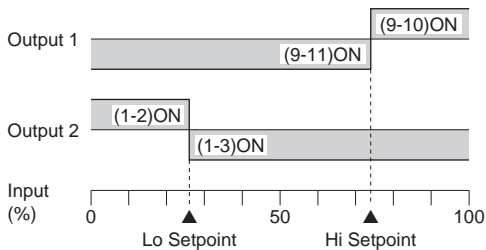

Trip Operation in Power Failure: Terminals 1 – 3, 9 – 11 turn on.

INSTALLATION

Power input

•AC: Operational voltage range: rating $\pm 10\%$,
50/60 ± 2 Hz, approx. 3 VA

•DC: Operational voltage range: rating $\pm 10\%$,
ripple 10 %p-p max., approx. 3 W (120 mA at 24 V)

Operating temperature: -5 to +60°C (23 to 140°F)

Operating humidity: 30 to 90 %RH (non-condensing)

Mounting: Surface or DIN rail

Weight: 400 g (0.88 lb)

PERFORMANCE in percentage of span

Setpoint accuracy: $\pm 0.5\%$

Display accuracy: $\pm 0.1\%$

Deadband setpoint accuracy: $\pm 0.3\%$

Trip point repeatability: $\pm 0.1\%$

Temp. coefficient: $\pm 0.015\%/^{\circ}\text{C}$ ($\pm 0.008\%/^{\circ}\text{F}$)

Response time: ≤ 0.5 sec. (0 - 100 % at 90 % setpoint)

Line voltage effect: $\pm 0.1\%$ over voltage range

Insulation resistance: ≥ 100 M Ω with 500 V DC

Dielectric strength: 2000 V AC @1 minute (input to output)

STANDARDS & APPROVALS

EU conformity:

EMC Directive

EMI EN 61000-6-4

EMS EN 61000-6-2

Low Voltage Directive

EN 61010-1

Measurement Category II (output)

Installation Category II (power)

Pollution Degree 2

Input to output to power: Basic insulation (300 V)

RoHS Directive

EN 50581

Approval:

UL/C-UL general safety requirements

(UL 3111-1, CAN/CSA-C22.2 No.1010-1)

EXTERNAL VIEW

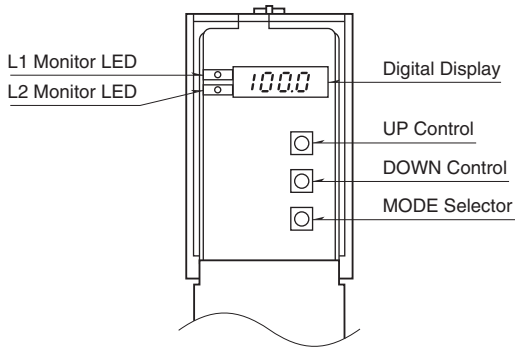

EXTERNAL DIMENSIONS unit: mm (inch)

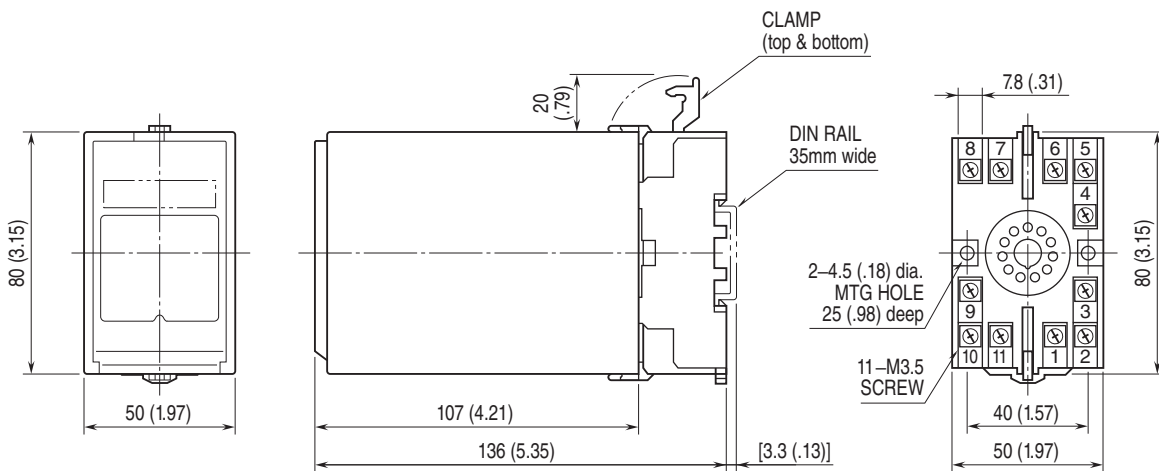

• When mounting, no extra space is needed between units.

TERMINAL ASSIGNMENTS unit: mm (inch)

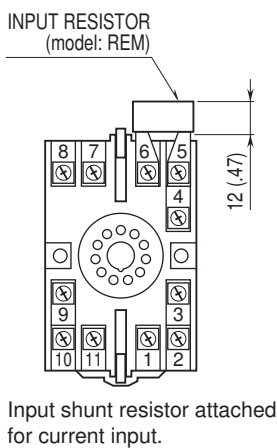

SCHEMATIC CIRCUITRY & CONNECTION DIAGRAM

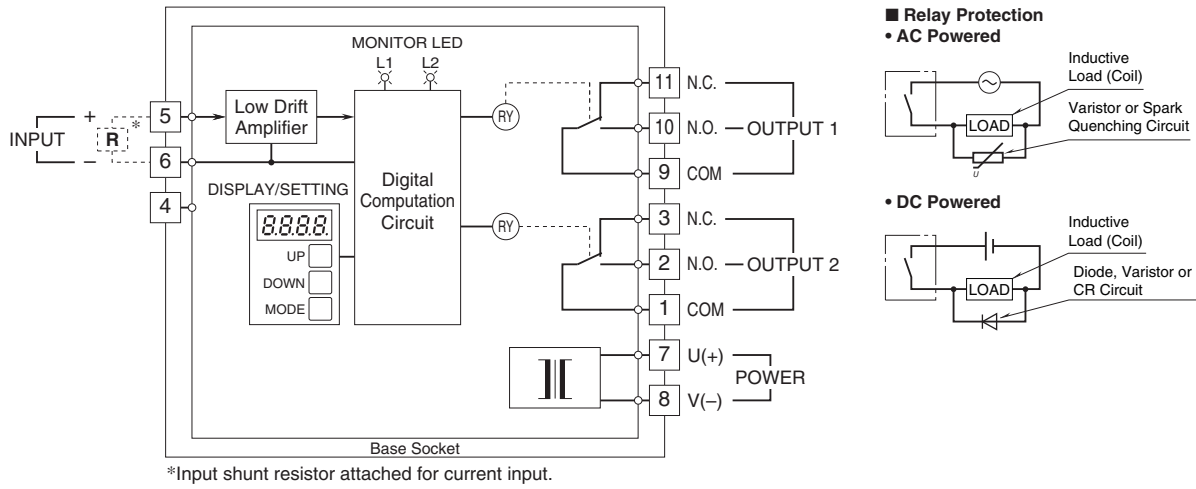

Specifications are subject to change without notice.