

0.5mm Pitch Connectors with Ground Plate for Board-to-Board Connections

FX10 Series

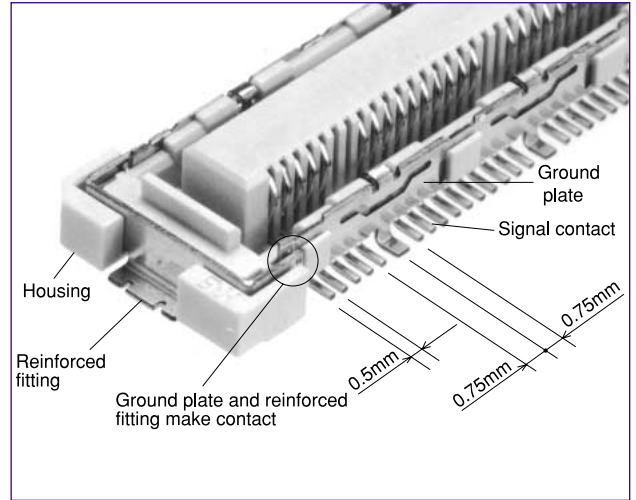
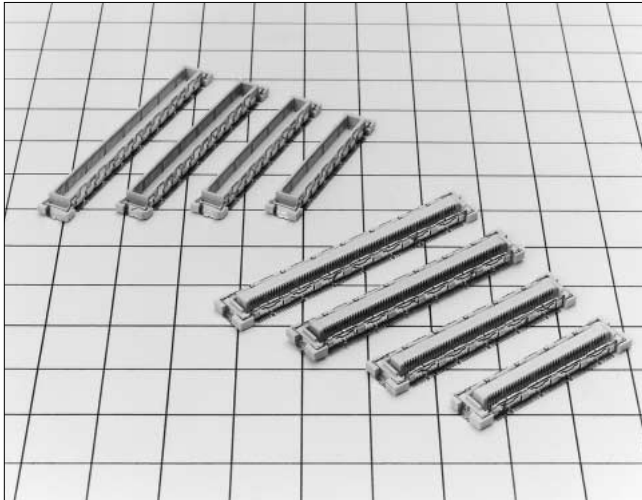

■ Features

1. Improved Transmission Efficiency Between Boards

Transmission characteristics have been improved through a design that fixes ground plates to both sides of the header and receptacle.

2. 10 Signal:1 Ground Arrangement

Signal and ground are arranged in a ratio of 10:1 with the ground plate SMT connected to the board. The ground stability achieved serves to reduce noise.

3. Reinforced Fittings for Added Solder Weld Strength

Reinforced fittings provide greater adhesion to the board, protecting against peeling. The unique connector design provides a connection between the fitting and the ground plate for a stronger ground.

4. Suited to High-Density Applications

The signal contact pitch of 0.5 mm produces a smaller connector utilizing less board area for mounting.

5. Board-To-Board Dimensions of 4mm and 5 mm Are Available

Cross-Section of Mating

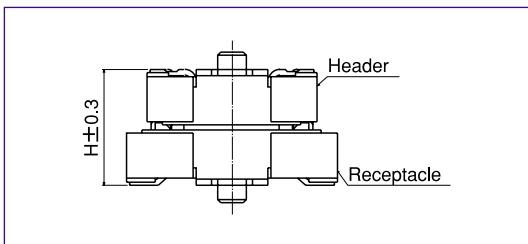
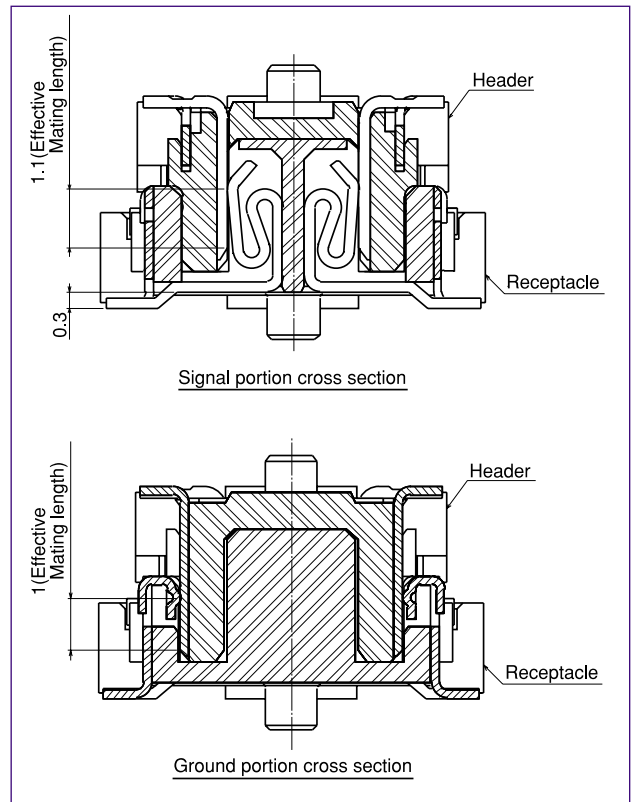

Stack Height

Receptacles	FX10# - *S/* - SV
Headers	Dimension H
FX10# - *P/* - SV1	4mm
FX10# - *P/* - SV1	5mm

Note: The thickness of the solder paste is not included in the stack height (dimension H).

■ Applications

Notebook computers, PDA, and other miniature electronic equipment.

Product Specifications

Rating	Rated current Rated voltage	0.3 A (Note 1) 50 V AC	Operating temperature range Operating humidity range	-55 to 85°C Relative humidity 95% or less (No condensation)	Storage temperature range Storage humidity range	-10 to +60°C (Note 2) 40 to 70% (Note 2)
--------	--------------------------------	---------------------------	---	---	---	---

Item	Requirements	Conditions
1. Insulation resistance	100 MΩ or greater	Measured at 100 V DC
2. Voltage proof	No flashover or breakdown	150 V AC applied for one minute
3. Contact resistance	60 mΩ or less	Measured at 100 mA
4. Vibration	No electrical discontinuity for 1μs or greater No damage, cracks, or parts looseness	Frequency: 10 to 55 Hz, amplitude of 0.75 mm in 3 directions, 10 cycles each
5. Shock	No electrical discontinuity for 1μs or longer No damage, cracks, or parts looseness	Acceleration of 490 m/s ² , 11 ms duration, sine half-wave waveform, for 3 cycles in the both directions of each of the 3 axes
6. Damp heat (Steady state)	Contact resistance of 70 mΩ or less, insulation resistance of 100 MΩ or greater, no damage, cracks, or parts looseness	Temperature of 40°C, humidity of 90 to 95%, duration 96 h
7. Rapid change of temperature	Contact resistance of 70 mΩ or less, insulation resistance of 100 MΩ or greater, no damage, cracks, or parts looseness	Temperature: -55°C → 15 to 35°C → 85°C → 15 to 35°C Time: 30 min. → 2 to 3 min. → 30 min. → 2 to 3 min. for 5 cycles
8. Insertion/Withdrawal life	Contact resistance of 70 mΩ or less No damage, cracks, or parts looseness	50 times
9. Resistance to soldering heat	No melting of resin portion which affects performance	Reflow: At the recommended temperature profile Soldering iron temperature: 300°C for 3 seconds

Note 1: Please contact us when connector application exceeds 0.3 A rated current.

Note 2: The term storage refers to an unused products prior to board mounting (including packing materials) that is being kept for a long period.

The operating temperature and humidity range are suited to the non-conducting condition following board assembly.

Note 3: The aforementioned specifications are representative of this series. For information on specific parts, confirm with Sales Office.

Materials

Part	Material	Process	Notes
Insulator	LCP resin	Beige	UL94V-0
Contacts	Phosphor bronze	Header Engagement Area: Gold plating of 0.1μm Termination Area: Solder plating	—
		Receptacle Engagement Area: Gold plating of 0.1m Termination Area: Flash plating	
Ground plate	Phosphor bronze	Solder plating	—
Reinforced fitting	Phosphor bronze	Tin plating	—

Note : The black dots on the insulator will not affect performance.

Product Number Configuration

Please use this information to discern the product specifications from the product number codes.

To order, please select from the product number codes listed in tables on pages 3 to 5 of this catalog.

FX 10 # - * P / * - SV 1 ()**

①
②
③
⑤
⑥
⑦
⑧

④

① Series name: FX	⑥ Contact form SV: Straight SMT
② Series No.: 10	⑦ Product height Blank: Standard 1 : Standard + 1mm
③ Form Symbol A: With guide post B: Without guide post	⑧ Packaging classification Blank: Tray packaging (21) : Embossed tape packaging
④ Number of contacts Signal/Ground: 80/8, 100/10, 120/12, 140/14	
⑤ Connector type P: Header S: Receptacle	

Receptacles

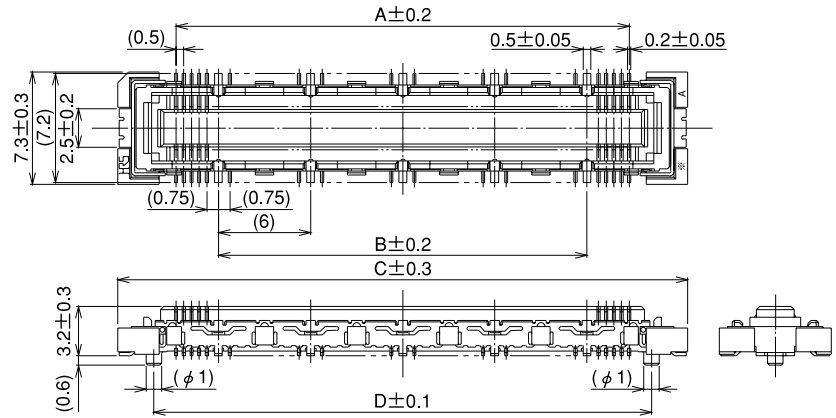

Unit: mm

HRS No.	Product No.	Number of Contacts		A	B	C	D	E	F	Notes
		Signal	Ground							
CL570-0201-4-***	FX10A- 80S/ 8-SV(**)	80	8	23.5	18	31.1	26.4	31.5	28.3	With guideposts
CL570-0202-7-***	FX10A-100S/10-SV(**)	100	10	29.5	24	37.1	32.4	37.5	34.3	
CL570-0203-0-***	FX10A-120S/12-SV(**)	120	12	35.5	30	43.1	38.4	43.5	40.3	
CL570-0204-2-***	FX10A-140S/14-SV(**)	140	14	41.5	36	49.1	44.4	49.5	46.3	
CL570-0221-1-***	FX10B- 80S/ 8-SV(**)	80	8	23.5	18	31.1	—	31.5	28.3	Without guideposts
CL570-0222-4-***	FX10B-100S/10-SV(**)	100	10	29.5	24	37.1	—	37.5	34.3	
CL570-0223-7-***	FX10B-120S/12-SV(**)	120	12	35.5	30	43.1	—	43.5	40.3	
CL570-0224-0-***	FX10B-140S/14-SV(**)	140	14	41.5	36	49.1	—	49.5	46.3	

[Specifications number]- **,(**)
 Blank: Tray packaging
 (21) :Embossed tape packaging

Note 1: There is no polarity in terms of board mounting for this product.

Note 2: The coplanarity of this product's SMT leads is 0.1 mm or less.

Note 3: Please order embossed tape packaged items by the reel. (One reel holds 1,000 pieces.)

Recommended Land Pattern Dimensions (Metal Mask Dimensions)

Recommended metal mask thickness: 0.15 mm

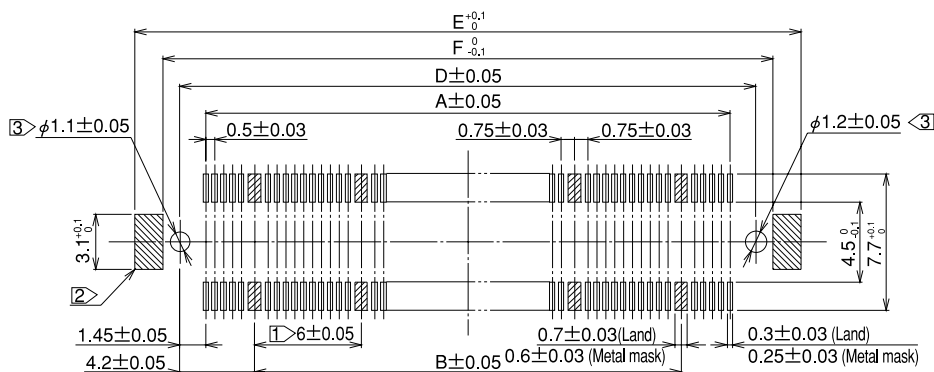

Note ① Cross-hatched portions, totaling n places, indicate the ground circuits.

② Cross-hatched portions, 2 places on both sides, indicate the reinforced fittings.

③ Not required in products without guideposts.

■ Headers

●4mm Mounting Height

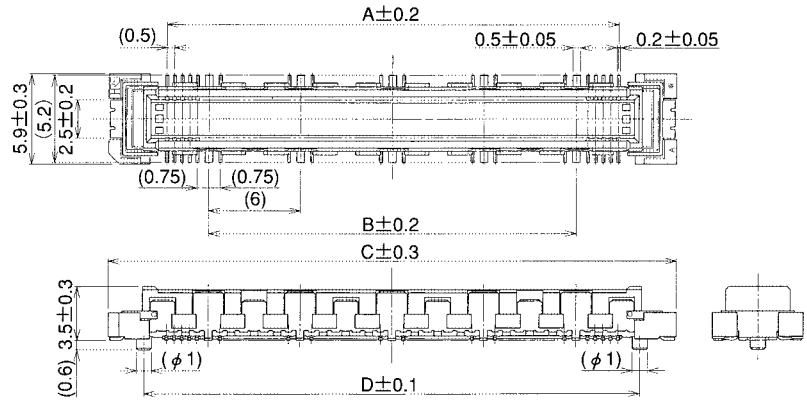

Unit: mm

HRS No.	Product No.	Number of Contacts		A	B	C	D	E	F	Notes
		Signal	Ground							
CL570-0001-5-*	FX10A- 80P/ 8-SV(**)	80	8	23.5	18	31.1	26.4	31.5	28.3	With guideposts
CL570-0002-8-*	FX10A-100P/10-SV(**)	100	10	29.5	24	37.1	32.4	37.5	34.3	
CL570-0003-0-*	FX10A-120P/12-SV(**)	120	12	35.5	30	43.1	38.4	43.5	40.3	
CL570-0004-3-*	FX10A-140P/14-SV(**)	140	14	41.5	36	49.1	44.4	49.5	46.3	
CL570-0021-2-*	FX10B- 80P/ 8-SV(**)	80	8	23.5	18	31.1	-	31.5	28.3	Without guideposts
CL570-0022-5-*	FX10B-100P/10-SV(**)	100	10	29.5	24	37.1	-	37.5	34.3	
CL570-0023-8-*	FX10B-120P/12-SV(**)	120	12	35.5	30	43.1	-	43.5	40.3	
CL570-0024-0-*	FX10B-140P/14-SV(**)	140	14	41.5	36	49.1	-	49.5	46.3	

[Specifications number] -*, (**)
 Blank: Tray packaging
 (21) : Embossed tape packaging

Note 1: There is no polarity in terms of board mounting for this product.

Note 2: The coplanarity of this product's SMT leads is 0.1mm or less.

Note 3: Please order embossed tape packaged items by the reel. (One reel holds 1,000 pieces.)

◆ Recommended Land Pattern Dimensions (Metal Mask Dimensions)

Recommended metal mask thickness: 0.15 mm

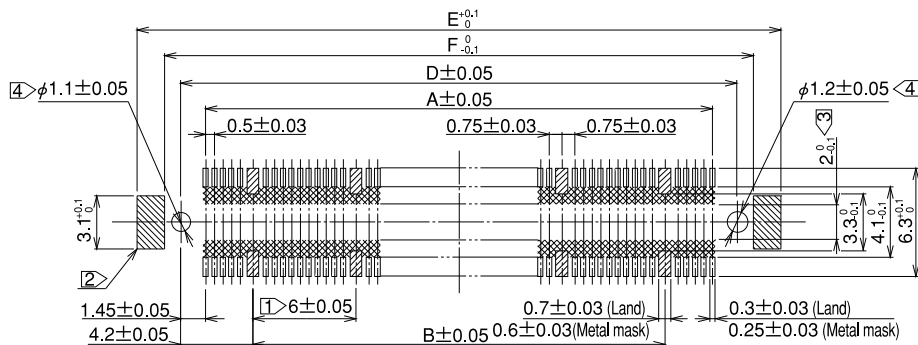

Note ① Cross-hatched portions, totaling n places, indicate the ground circuits.

② Cross-hatched portions, 2 places on both sides, indicate the reinforced fittings.

③ The cross-hatched area  inside the SMT land may come into contact with the connector contacts and thus care should be taken that the pattern does not extend beyond the SMT land width.

④ Not required in products without guideposts.

■Headers

●5mm Mounting Height

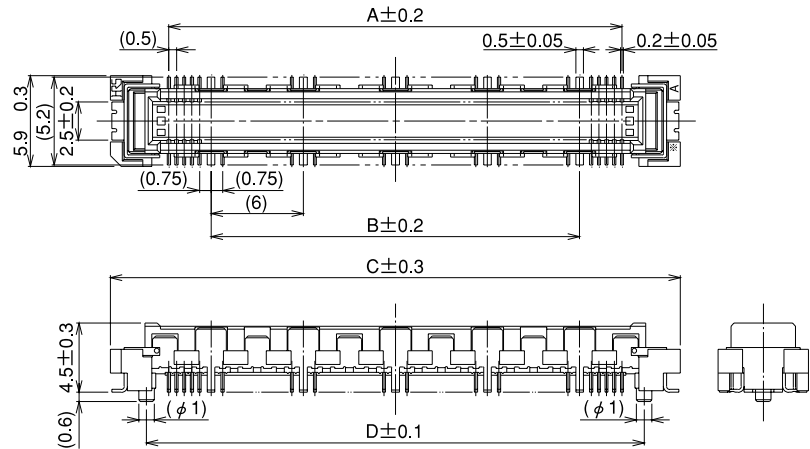

Unit: mm

HRS No.	Product No.	Number of Contacts		A	B	C	D	E	F	Notes
		Signal	Ground							
CL570-0101-0-***	FX10A- 80P/ 8-SV1(**)	80	8	23.5	18	31.1	26.4	31.5	28.3	With guideposts
CL570-0102-2-***	FX10A-100P/10-SV1(**)	100	10	29.5	24	37.1	32.4	37.5	34.3	
CL570-0103-5-***	FX10A-120P/12-SV1(**)	120	12	35.5	30	43.1	38.4	43.5	40.3	
CL570-0104-8-***	FX10A-140P/14-SV1(**)	140	14	41.5	36	49.1	44.4	49.5	46.3	
CL570-0121-7-***	FX10B- 80P/ 8-SV1(**)	80	8	23.5	18	31.1	-	31.5	28.3	Without guideposts
CL570-0122-0-***	FX10B-100P/10-SV1(**)	100	10	29.5	24	37.1	-	37.5	34.3	
CL570-0123-2-***	FX10B-120P/12-SV1(**)	120	12	35.5	30	43.1	-	43.5	40.3	
CL570-0124-5-***	FX10B-140P/14-SV1(**)	140	14	41.5	36	49.1	-	49.5	46.3	

[Specifications number] -**,(**)

Blank: Tray packaging

(21) : Embossed tape packaging

Note 1: There is no polarity in terms of board mounting for this product.

Note 2: The coplanarity of this product's SMT leads is 0.1 mm or less.

Note 3: Please order embossed tape packaged items by the reel. (One reel holds 1,000 pieces.)

◆Recommended Land Pattern Dimensions (Metal Mask Dimensions)

Recommended metal mask thickness: 0.15 mm

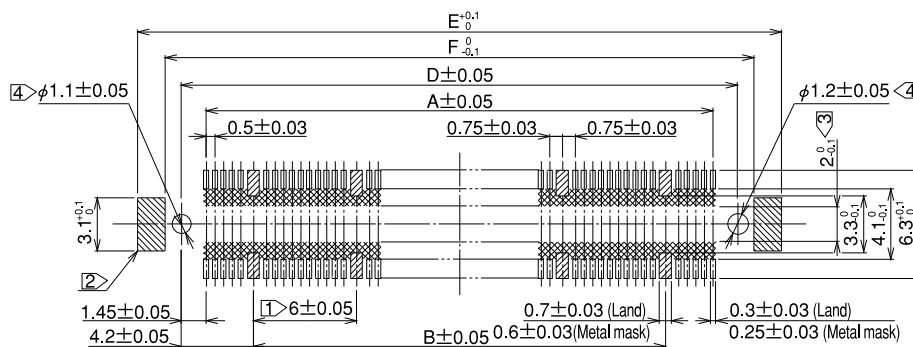

Note ① Cross-hatched portions, totaling n places, indicate the ground circuits.

② Cross-hatched portions, 2 places on both sides, indicate the reinforced fittings.

③ The cross-hatched area  inside the SMT land may come into contact with the connector contacts and thus care should be taken that the pattern does not extend beyond the SMT land width.

④ Not required in products without guideposts.

◆ Embossed Carrier Tape Dimensions

● Receptacles

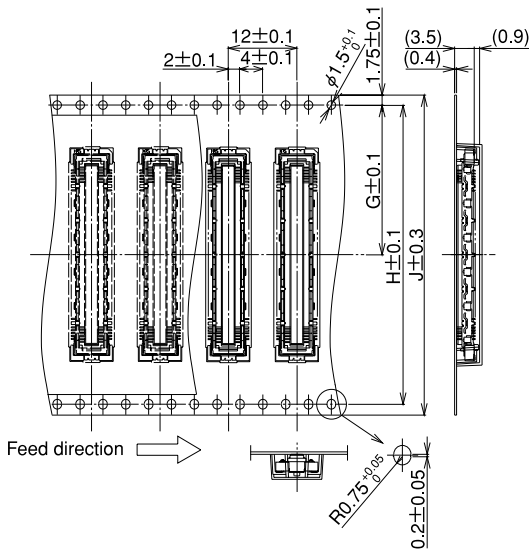

Insertion Connector	G	H	J	L	M	N
FX10#- 80S/ 8-SV	20.2	40.4	44	330	45.5	50.5
FX10#-100S/10-SV	26.2	52.4	56	330	59	64
FX10#-120S/12-SV	26.2	52.4	56	330	59	64
FX10#-140S/14-SV	34.2	68.4	72	330	76.5	81.5

Note: There is no polarity in terms of embossed tape packaging for this product.

● Headers

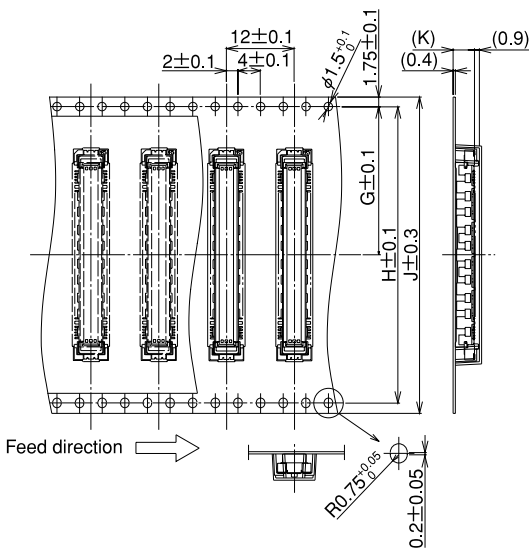

Insertion Connector	G	H	J	K	L	M	N
FX10#- 80P/ 8-SV	20.2	40.4	44	3.8	330	45.5	50.5
FX10#-100P/10-SV	26.2	52.4	56	3.8	330	59	64
FX10#-120P/12-SV	26.2	52.4	56	3.8	330	59	64
FX10#-140P/14-SV	34.2	68.4	72	3.8	330	76.5	81.5
FX10#- 80P/ 8-SV1	20.2	40.4	44	4.8	370	45.5	50.5
FX10#-100P/10-SV1	26.2	52.4	56	4.8	370	59	64
FX10#-120P/12-SV1	26.2	52.4	56	4.8	370	59	64
FX10#-140P/14-SV1	34.2	68.4	72	4.8	370	76.5	81.5

Note: There is no polarity in terms of embossed tape packaging for this product.

● Reel Packaging Dimensions

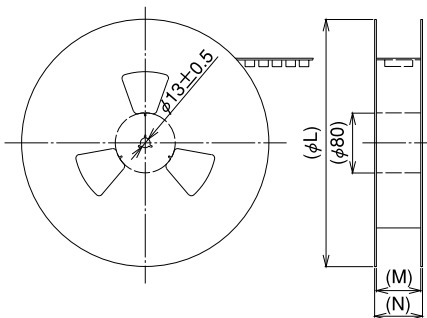

◆ Recommended Temperature Profile

This temperature profile is a reference for the setting conditions described below. It will differ depending on conditions and so mounting should follow verification.

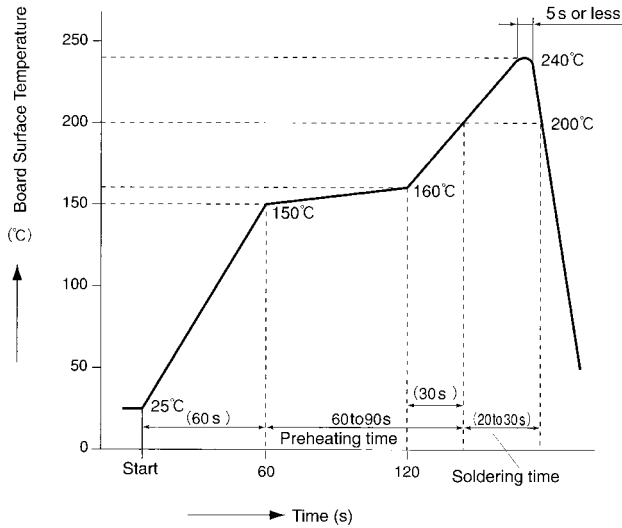

Applicable Conditions

Reflow method : IR reflow

Solder : Cream type 63Sn/37Pb
(Flux component of 9wt%)

Test substrate : Glass epoxy. 85 x 110 x 1.6mm

Metal mask thickness : 0.15mm

This temperature profile is a recommendation. Conditions may change somewhat depending on the type of cream solder and the amount.

◆ Washing Conditions

Organic Solvent Washing

Solvent	Room temperature washing	Heated washing
IPA (Isopropyl alcohol)	Yes	Yes
HCFC (Hydrochlorofluorocarbon)	Yes	Yes

Water Type Washing

When using water type cleaning agents (e.g., terpene, and alkali saponifiers), select the cleaning agent based on the documentation issued by the various manufacturers of cleaning agents which describes the effects on metals and resins. Be careful that parts are not left with moisture remaining on them.

Washing Precautions

Residual flux or cleaning agent on the contacts when washing with organic solvents or water type cleaners can give rise to the deterioration of electrical performance. In this regard it is important to check whether a thorough washing has been performed.

◆ Connector Handling Precautions

1. Allowable Creepage Dimensions at Time of Mating

The effective coupling length of this product is 1.1 mm for the signal portion and 1 mm for the ground portion. The creepage of the header and receptacle at the time of mating should be within 0.5 mm of the completely coupled condition.

2. Retension of Boards

Avoid the support of boards by connectors alone and adopt a locking measure that does not rely on the connectors.

3. Solder Repair

Flux may rise as far as the contact portion of the connector depending on the flux coating and other factors at the time of repair. This will cause poor contact reliability; therefore, before use, the aforementioned washing conditions should be taken into consideration prior to connector washing.

4. Miscellaneous

·Note that excessive twisting while inserting or withdrawing connectors will cause damage.

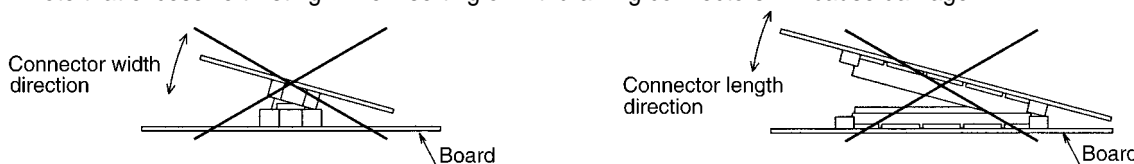

·The shade of the molded items may vary somewhat depending on the manufacturing lot; however, this does not affect performance.