

# TECHNICAL DATA

## SE1117-X.X

LDO Linear Regulator

### Features

- ◆ Adjustable and Fixed of 1.8V, 2.5V, 3.3V, 5.0V
- ◆ Space saving SMD types of SOT-223
- ◆ Output Current up to 1A
- ◆ Low Dropout Voltage ( 700mV at 1A Output Current )
- ◆ Very Low Quiescent Current
- ◆ Internal Current and Terminal Limit
- ◆ Output trimmed to ±2% Tolerance
- ◆ 0.04% Line Regulation, 0.1% Load Regulation

### General Description

The SE1117 is a low power positive-voltage regulator designed to meet 1A of output current.

The SE1117 features very low quiescent current and very low dropout voltage of 700mV at a full load and lower as output current decreases.

The SE1117 is available in four fixed voltages, 1.8V, 2.5V, 3.3V and 5.0V.

Additionally it is also available in adjustable version.

The SE1117 series is offered in a 3-pin SOT-223 packages.

A minimum of 10uF capacitor is required at the output to improve the transient response and stability.

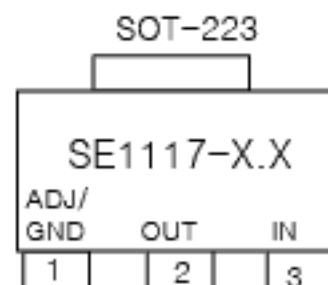

### Applications

- ◆ Post Regulator for switching DC/DC Converter
- ◆ High Efficiency Linear Regulator
- ◆ Battery Chargers
- ◆ PC Add on Card
- ◆ Motherboard clock supplies

### Absolute Maximum Ratings

Parameter	Symbol	Value	Units
Input Voltage	$V_{IN(MAX)}$	7	V
Junction Temperature	$T_J$	0 ~ +125	°C
Storage Temperature	$T_{STG}$	-55 ~ +150	°C
Lead Temperature	$T_{SOL}$	Max. 260	°C

### Electrical Characteristics

( $C_o = 10\mu F$ ,  $T_a = 25^\circ C$ , unless otherwise specified)

Parameter	Symbol	Test Condition	Min.	Typ.	Max.	Units
Reference Voltage	$V_{REF}$	SE1117-AD Only $1.4V < (V_{IN} - V_{OUT}) < 10V$ , $10mA < I_o < 1A$	1.225	1.250	1.275	V
Output Voltage	$V_{OUT}$	SE1117-1.8 $0 < I_{OUT} < 1A$ , $3.9V < V_{IN} < 10V$	1.764	1.800	1.836	V
		SE1117-2.5 $0 < I_{OUT} < 1A$ , $3.9V < V_{IN} < 10V$	2.450	2.500	2.550	V
		SE1117-3.3 $0 < I_{OUT} < 1A$ , $4.75V < V_{IN} < 10V$	3.234	3.300	3.366	V
		SE1117-5.0 $0 < I_{OUT} < 1A$ , $6.5V < V_{IN} < 15V$	4.900	5.000	5.100	V

## Electrical Characteristics

(V<sub>IN</sub> = 5V, C<sub>O</sub> = 10μF, T<sub>A</sub> = 25 °C, unless otherwise specified)

Parameter	Symbol	Test Condition	Min.	Typ.	Max.	Units
Line Regulation	dV <sub>OUT1</sub>	SE1117-AD I <sub>OUT</sub> =10mA, 1.6V < (V <sub>IN</sub> -V <sub>OUT</sub> ) < 13.6V	-	0.036	0.2	%
		SE1117-1.8 I <sub>OUT</sub> =0mA, 3.9V < V <sub>IN</sub> < 10V	-	0.04	0.2	mV
		SE1117-2.6 I <sub>OUT</sub> =0mA, 3.9V < V <sub>IN</sub> < 10V	-	0.04	0.2	mV
		SE1117-3.3 I <sub>OUT</sub> =0mA, 4.75V < V <sub>IN</sub> < 16V	-	0.04	0.2	mV
		SE1117-6.0 I <sub>OUT</sub> =0mA, 6.60V < V <sub>IN</sub> < 16V	-	0.04	0.2	mV
		Load Regulation	dV <sub>OUT2</sub>	SE1117-AD V <sub>IN</sub> -V <sub>OUT</sub> =3V, 10mA < I <sub>OUT</sub> < 1A	-	0.1
		SE1117-1.8 V <sub>IN</sub> =3.9V, 0 < I <sub>OUT</sub> < 1A	-	0.08	0.4	mV
		SE1117-2.6 V <sub>IN</sub> =3.9V, 0 < I <sub>OUT</sub> < 1A	-	0.08	0.4	mV
		SE1117-3.3 V <sub>IN</sub> =4.75V, 0 < I <sub>OUT</sub> < 1A	-	0.08	0.4	mV
		SE1117-6.0 V <sub>IN</sub> =6.6V, 0 < I <sub>OUT</sub> < 1A	-	0.08	0.4	mV
Dropout Voltage 1	V <sub>DROPE1</sub>	SE1117-AD I <sub>OUT</sub> =100mA, V <sub>IN</sub> =V <sub>OUT</sub> +0.8V	-	1.0	1.1	V
		Others I <sub>OUT</sub> =100mA	-			
Dropout Voltage 2	V <sub>DROPE2</sub>	SE1117-AD I <sub>OUT</sub> =1A, V <sub>IN</sub> =V <sub>OUT</sub> +0.8V	-	1.0	1.3	V
		Others I <sub>OUT</sub> =800mA	-	1.1	1.2	
Quiescent Current	I <sub>Q</sub>	SE1117-1.8, 2.6, 3.3 V <sub>IN</sub> < 10V	-	5	10	mA
		SE1117-6.0 V <sub>IN</sub> < 16V	-			
Supply Voltage Rejection	SVR	SE1117-AD f=120Hz, V <sub>NIPPLE</sub> =1V <sub>PP</sub> , V <sub>IN</sub> -V <sub>OUT</sub> =3V, I <sub>OUT</sub> =40mA	60	76	-	dB
		SE1117-1.8 f=120Hz, V <sub>NIPPLE</sub> =1V <sub>PP</sub> , V <sub>IN</sub> =5.5V, I <sub>OUT</sub> =40mA				
		SE1117-2.6 f=120Hz, V <sub>NIPPLE</sub> =1V <sub>PP</sub> , V <sub>IN</sub> =5.5V, I <sub>OUT</sub> =40mA				
		SE1117-3.3 f=120Hz, V <sub>NIPPLE</sub> =1V <sub>PP</sub> , V <sub>IN</sub> =6.6V, I <sub>OUT</sub> =40mA				
		SE1117-6.0 f=120Hz, V <sub>NIPPLE</sub> =1V <sub>PP</sub> , V <sub>IN</sub> =6.6V, I <sub>OUT</sub> =40mA				
Adjust Pin Current	I <sub>ADJ</sub>	V <sub>IN</sub> <16V, I <sub>LOAD</sub> =10mA	-	50	120	μA
Adjust Pin Current Change	I <sub>CHG</sub>	10mA < I <sub>OUT</sub> < 1A 1.4V < V <sub>IN</sub> - V <sub>OUT</sub> < 10V	-	1	5	μA
Minimum Load Current	I <sub>MIN</sub>	Only SE1117-AD V <sub>IN</sub> = 16V		1.7	5	mA
Long Term Stability	Stable	T <sub>A</sub> = 125 °C, 1000hrs	-	0.3		%
Output Noise Voltage	V <sub>N</sub>	SE1117-AD 10Hz < f < 10kHz		0.003		%
		Others 10Hz < f < 10kHz	-	100	-	μV

## Typical Application

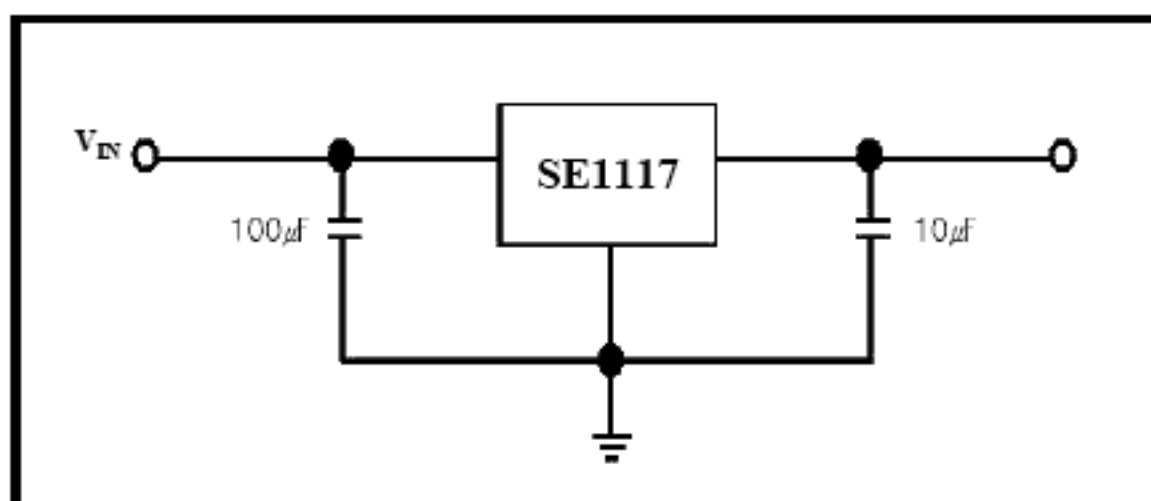

## Typical Adjustable Regulator

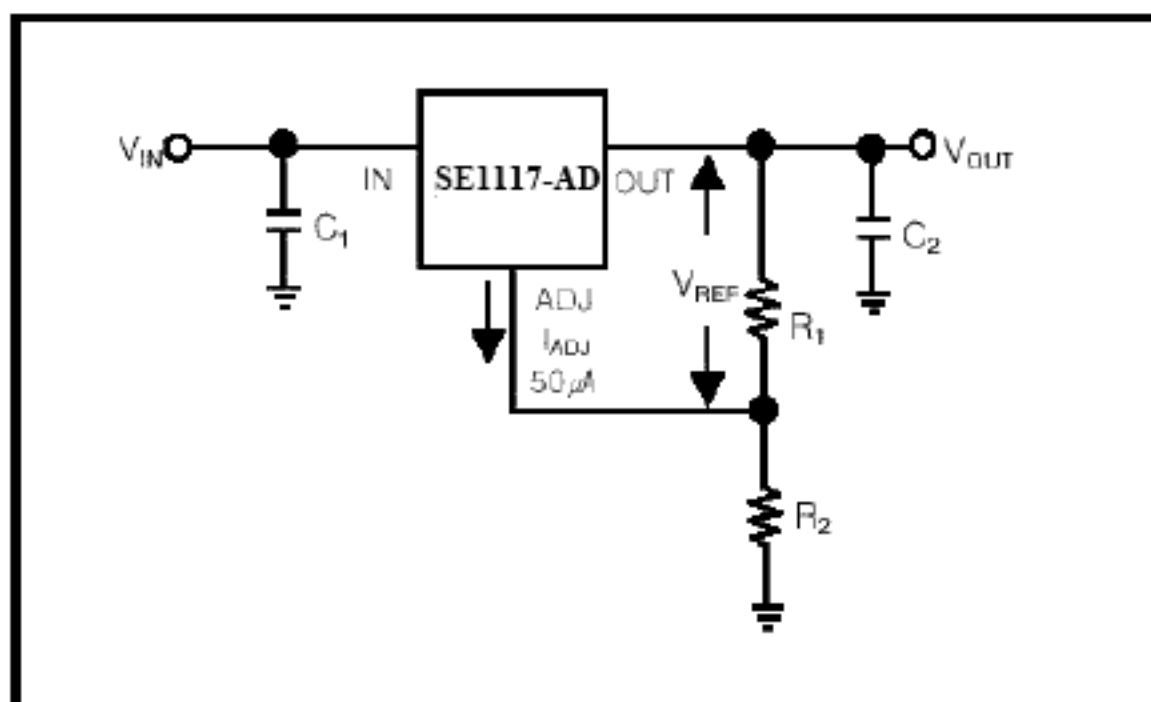

## Package Dimension

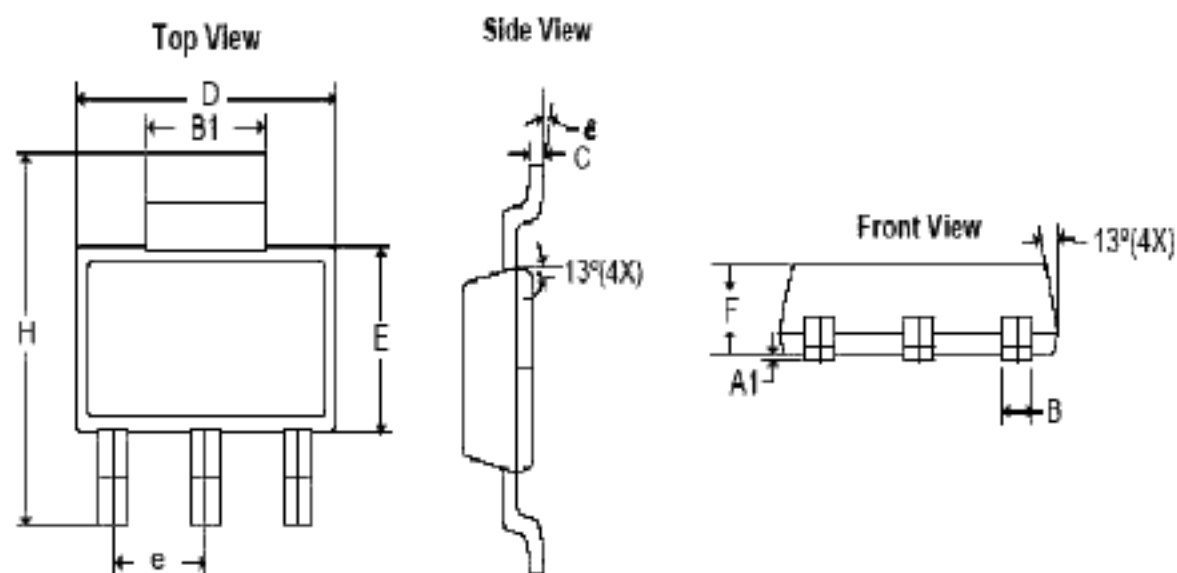

DIM	MILLIMETERS		INCHES	
	MIN	MAX	MIN	MAX
A	0.01	0.10	0.0004	0.0039
B	0.60	0.84	0.0236	0.0330
B1	2.90	3.15	0.1140	0.1240
C	0.24	0.38	0.0094	0.0150
D	6.30	6.71	0.2480	0.2640
E	3.30	3.71	0.1299	0.1460
e	2.20	2.40	0.0865	0.0944
F	1.50	1.75	0.0590	0.0688
H	6.70	7.30	0.2638	0.2874
$\theta$	$0^\circ$	$10^\circ$	$0^\circ$	$10^\circ$