

**PLEASE CHECK WWW.MOLEX.COM FOR LATEST PART INFORMATION**

**Part Number:** [0878030002](#)  
**Status:** **Active**  
**Description:** 1.00mm (.039") Pitch DDR-2 DIMM Socket, 25 Degree Angle, Through Hole, 1.8V Voltage Key, 2.79mm (.110") Tail Length, 0.38µm (15µ") Gold (Au) Plating, 240 Circuits, Lead-free

**Documents:**

[3D Model](#) [Product Specification PS-87803-003 \(PDF\)](#)  
[Drawing \(PDF\)](#) [RoHS Certificate of Compliance \(PDF\)](#)

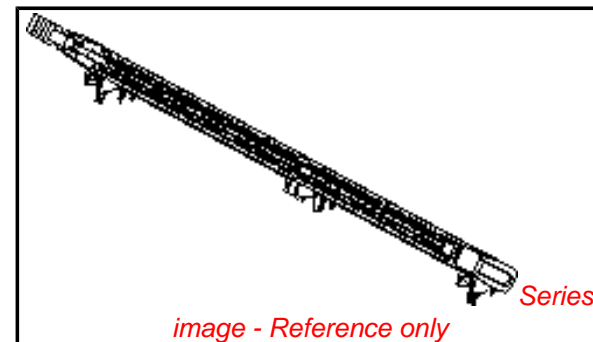

**Agency Certification**

CSA LR19980  
 UL E29179

**General**

Product Family Memory Module Sockets  
 Series [87803](#)  
 Comments <LI>No Lubricant at the Contact<LI>Latches in Off-White Color  
 Component Type Socket  
 JEDEC Outline MO-237  
 Product Name DDR2 DIMM

**Physical**

Circuits (Loaded) 240  
 Color - Resin Black, Natural  
 Durability (mating cycles max) 25  
 Entry Angle 25° Angle  
 Flammability 94V-0  
 Keying to Mating Part Yes  
 Material - Plating Mating Gold  
 Material - Plating Termination Tin  
 Material - Resin High Temperature Thermoplastic  
 PC Tail Length (in) 0.110 In  
 PC Tail Length (mm) 2.79 mm  
 PCB Locator Yes  
 PCB Retention Yes  
 PCB Thickness Recommended (in) 0.062 In  
 PCB Thickness Recommended (mm) 1.60 mm  
 Packaging Type Tray  
 Pitch - Mating Interface (in) 0.039 In  
 Pitch - Mating Interface (mm) 1.00 mm  
 Plating min: Mating (µin) 15  
 Plating min: Mating (µm) 0.38  
 Plating min: Termination (µin) 100  
 Plating min: Termination (µm) 2.54  
 Temperature Range - Operating -55°C to +85°C  
 Termination Interface: Style Through Hole

**Electrical**

Current - Maximum per Contact 0.5A  
 Voltage - Maximum 30V AC (RMS)/DC  
 Voltage Key 1.8V, Center

**Solder Process Data**

Duration at Max. Process Temperature (seconds) 5  
 Lead-free Process Capability SMC & Wave Capable (TH only)

**EU RoHS**  
**ELV and RoHS**  
**Compliant**  
**REACH SVHC**  
**Contains SVHC: No**  
**Halogen-Free**  
**Status**  
**Not Halogen-Free**

**China RoHS**



**Need more information on product environmental compliance?**

Email [productcompliance@molex.com](mailto:productcompliance@molex.com)  
 For a multiple part number RoHS Certificate of Compliance, [click here](#)

Please visit the [Contact Us](#) section for any non-product compliance questions.

**Search Parts in this Series**  
[87803Series](#)

**Mates With**  
 JEDEC standard 1.27mm modules

Max. Cycles at Max. Process Temperature	2
Process Temperature max. C	260

### **Material Info**

### **Reference - Drawing Numbers**

Product Specification	PS-87803-003
Sales Drawing	SD-87803-010

This document was generated on 04/09/2010

**PLEASE CHECK [WWW.MOLEX.COM](http://WWW.MOLEX.COM) FOR LATEST PART INFORMATION**

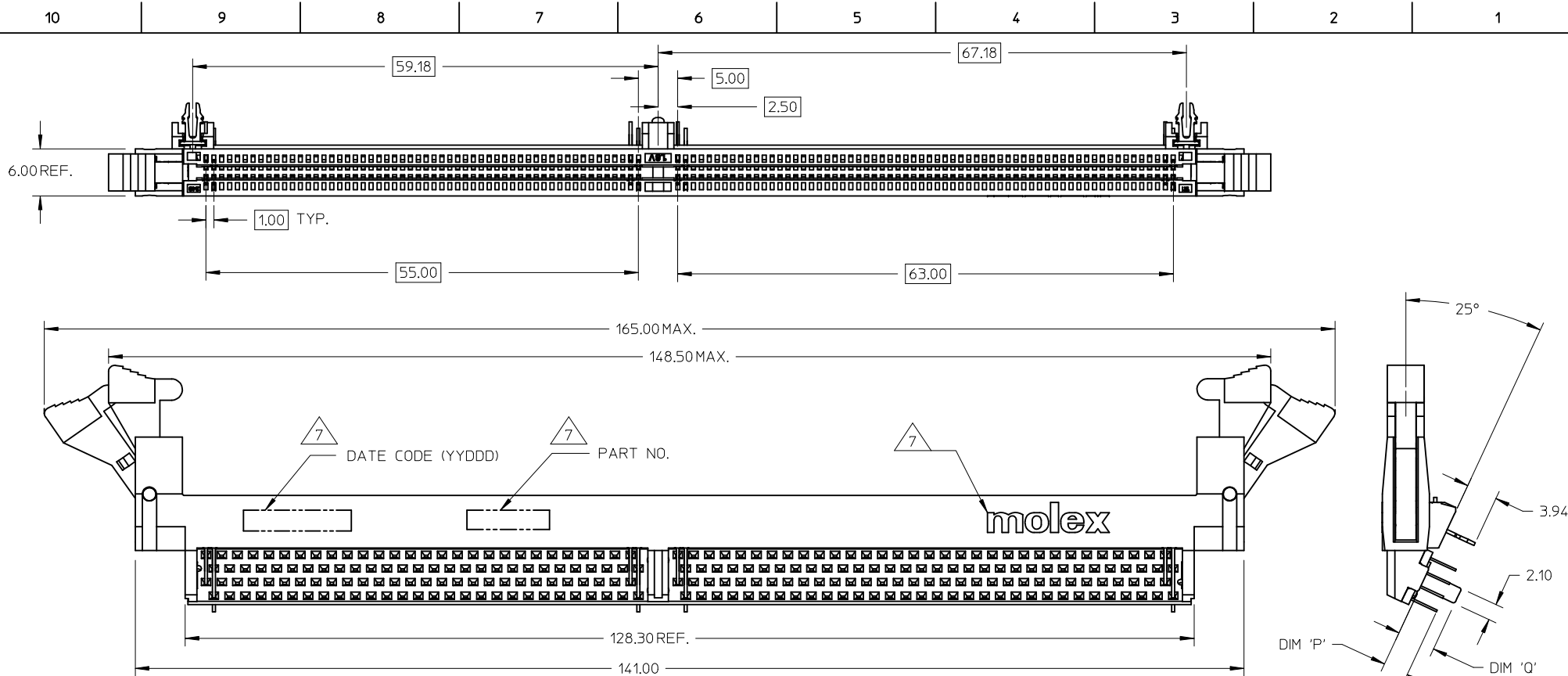

NOTES:

- MATERIALS : HOUSING AND BASEPLATE
  - LCP, GLASS FILLED, UL 94V-0, BLACK LATCH
  - HIGH TEMP. NYLON, GLASS FILLED, UL 94-0, NATURAL (OFF WHITE)
  - TERMINALS AND FORKLICK - COPPER ALLOY
- PLATING : CONTACT AREA - SEE TABLE IN SHEET 5  
SOLDERTAIL - SEE TABLE IN SHEET 5
- REFER TO PRODUCT SPECIFICATION, PS-87803-003 FOR PERFORMANCE SPECIFICATIONS.
- CARD SLOTS ACCEPTS 1.27±0.10 MM MODULE THICKNESS. (MEASURED OVER PC PADS)
- RECOMMENDED MODULE CARD LAYOUT SHALL BE AS PER JEDEC MO-237.
- PRODUCT IS PACKED IN TRAY.
- MOLEX LOGO, DATE CODE AND PART NUMBER INDICATED ON HOUSING.
- CONTACT MOLEX FOR AVAILABILITY OF PRODUCT OPTIONS.

ADDED OPTION EC NO: S2009-0629 DRW: CCTEH CHKD: CGTAN APPR: SILENI 2009/03/27 2009/03/27 2009/03/27	DESCRIPTION QUALITY SYMBOLS ▽=0 ◻=0	GENERAL TOLERANCES (UNLESS SPECIFIED)		DIMENSION STYLE	SCALE	DESIGN UNITS	THIRD ANGLE PROJECTION	
				MM ONLY	NTS	METRIC		
				DRAWN BY	DATE	TITLE		
				MLONG	2004/03/25	DDR2 DIMM, 1.00MM PITCH 240 CKTS, 25 DEG.		
		4 PLACES ± --- ± ---		CHECKED BY	DATE			
		3 PLACES ± --- ± ---		SRRAMESH	2004/03/26			
		2 PLACES ± 0.25 ± ---		APPROVED BY	DATE			
		1 PLACE ± --- ± ---		GGLEE	2004/03/26			
		ANGULAR ± 5 °		MATERIAL NO.	DOCUMENT NO.			
		DRAFT WHERE APPLICABLE MUST REMAIN WITHIN DIMENSIONS		SEE TABLE		MOLEX INCORPORATED		
				SIZE	SD-87803-010			
				A3	SHEET NO.			
				THIS DRAWING CONTAINS INFORMATION THAT IS PROPRIETARY TO MOLEX INCORPORATED AND SHOULD NOT BE USED WITHOUT WRITTEN PERMISSION				
				1 OF 5				

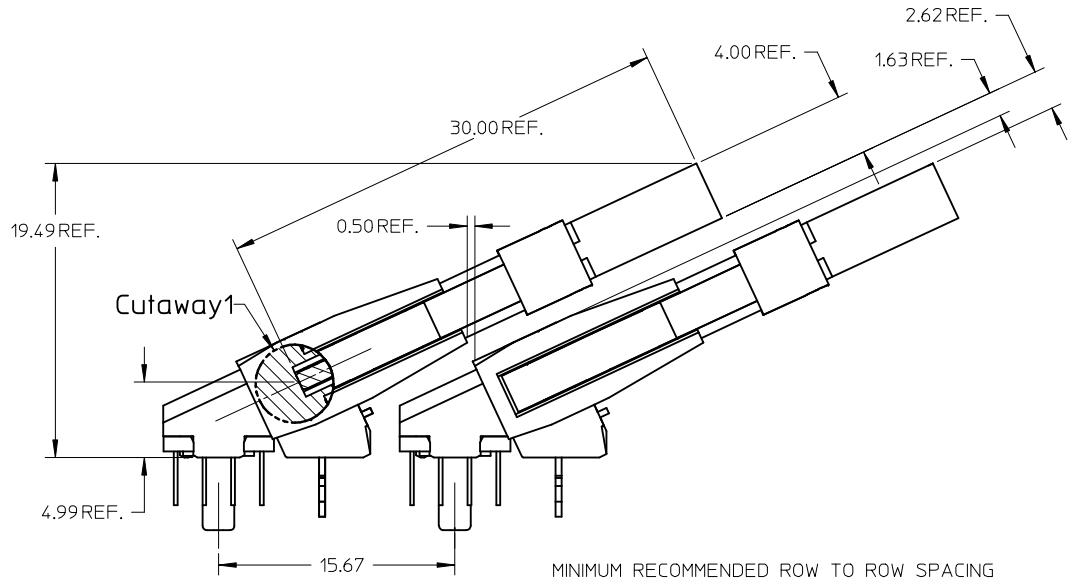

MINIMUM RECOMMENDED ROW TO ROW SPACING  
WHEN USING A 4.00MM THICK  
MODULE (TYPICAL TSOP PACKAGING)

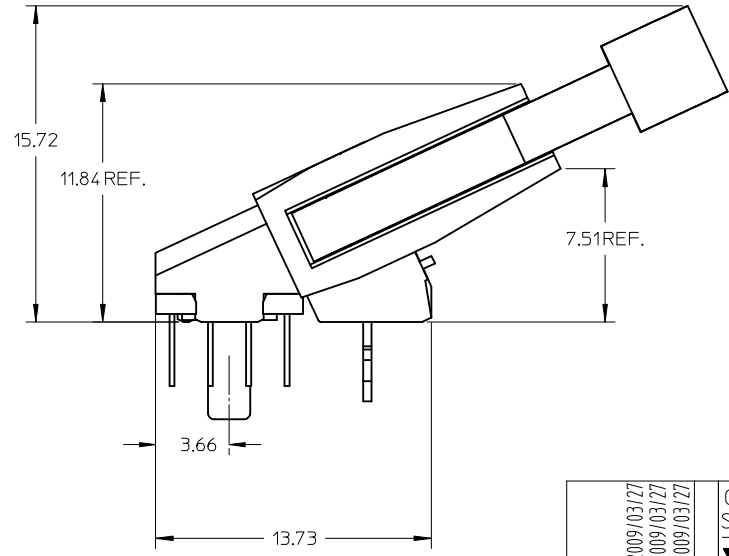

ADDED OPTION EC NO: S2009-0629 DRWN: CCTEH 2009/03/27 CH'KD: GGTAN 2009/03/27 APPR: SHLENI 2009/03/27	QUALITY SYMBOLS ▽=0 ▽=0	GENERAL TOLERANCES (UNLESS SPECIFIED)		DIMENSION STYLE MM ONLY		SCALE NTS	DESIGN UNITS METRIC	THIRD ANGLE PROJECTION		
			mm	INCH	DRAWN BY	DATE	TITLE			
		4 PLACES	± ---	± ---	MLONG	2004/03/25	DDR2 DIMM, 1.00MM PITCH			
		3 PLACES	± ---	± ---	CHECKED BY	DATE	240 CKTS, 25 DEG.			
	2 PLACES	± 0.25	± ---	SRRAMESH	2004/03/26	MOLEX INCORPORATED				
	1 PLACE	± ---	± ---	APPROVED BY	DATE	DOCUMENT NO.				
	ANGULAR ± 5 °		GGLLEE		2004/03/26	SD-87803-010				
	DRAFT WHERE APPLICABLE MUST REMAIN WITHIN DIMENSIONS		MATERIAL NO.		SEE TABLE		SHEET NO.			
			SIZE		A3		THIS DRAWING CONTAINS INFORMATION THAT IS PROPRIETARY TO MOLEX INCORPORATED AND SHOULD NOT BE USED WITHOUT WRITTEN PERMISSION			

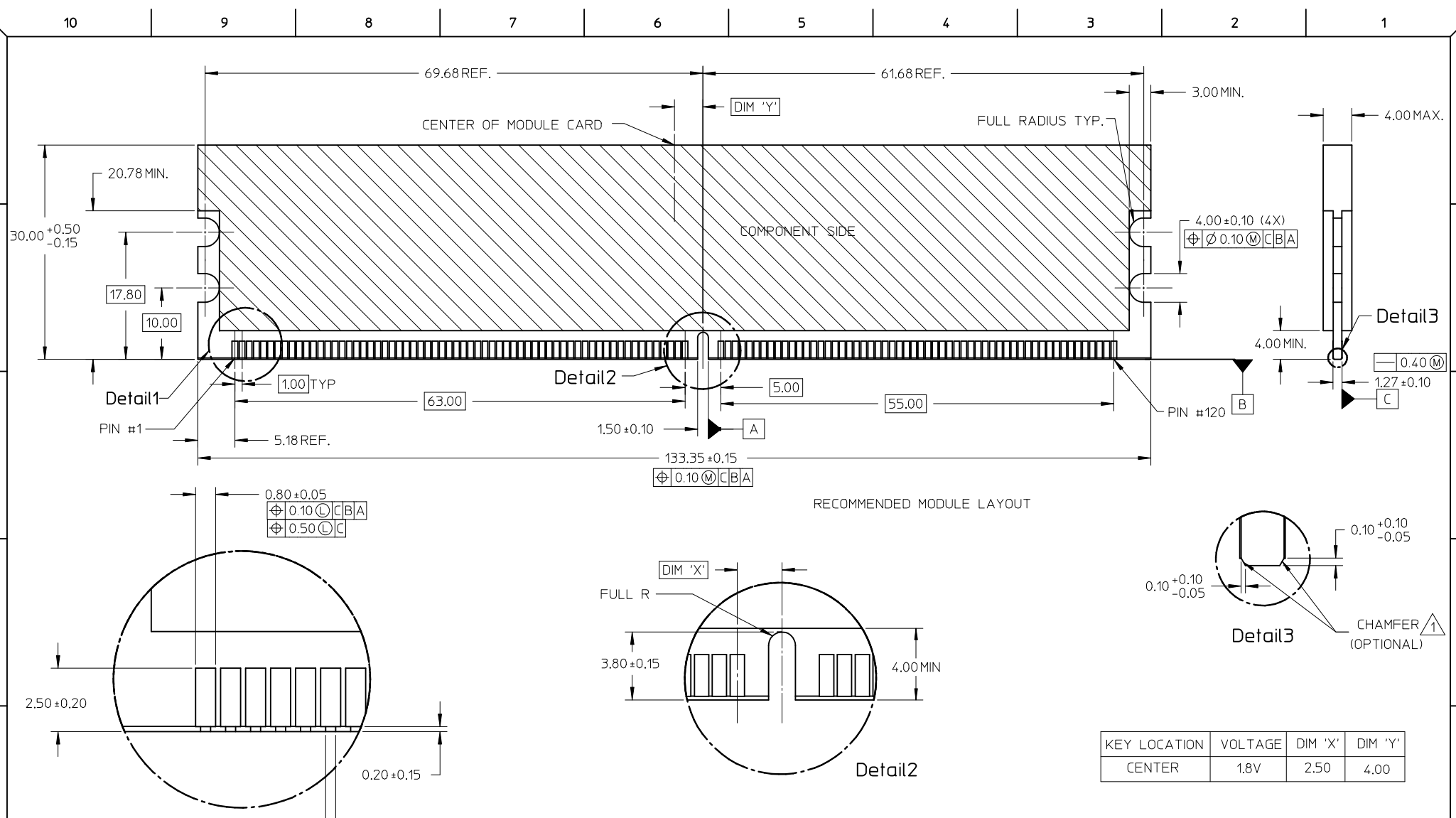

KEY LOCATION	VOLTAGE	DIM 'X'	DIM 'Y'
CENTER	1.8V	2.50	4.00

NOTES :  
 1 MODULE CARD USED IN PRODUCT TESTING ARE CHAMFERED.

ADDED OPTION  
 EC NO: S2009-0629  
 DRW:NCCTEH  
 CHKD:CGTAN  
 APPR:SHLENI

REV	DESCRIPTION
B1	

QUALITY SYMBOLS	GENERAL TOLERANCES (UNLESS SPECIFIED)	
	mm	INCH
▽=0	4 PLACES ± ---	± ---
◻=0	3 PLACES ± ---	± ---
	2 PLACES ± 0.25	± ---
	1 PLACE ± ---	± ---
	ANGULAR ± 5 °	
	DRAFT WHERE APPLICABLE MUST REMAIN WITHIN DIMENSIONS	

DIMENSION STYLE	
MM ONLY	
DRAWN BY	DATE
MLONG	2004/03/25
CHECKED BY	DATE
SRRAMESH	2004/03/26
APPROVED BY	DATE
GGLEE	2004/03/26
MATERIAL NO.	
SEE TABLE	

SCALE	DESIGN UNITS	THIRD ANGLE PROJECTION
NTS	METRIC	☉
TITLE		
DDR2 DIMM, 1.00MM PITCH 240 CKTS, 25 DEG.		
MOLEX INCORPORATED		SHEET NO.
DOCUMENT NO. SD-87803-010		3 OF 5
THIS DRAWING CONTAINS INFORMATION THAT IS PROPRIETARY TO MOLEX INCORPORATED AND SHOULD NOT BE USED WITHOUT WRITTEN PERMISSION		

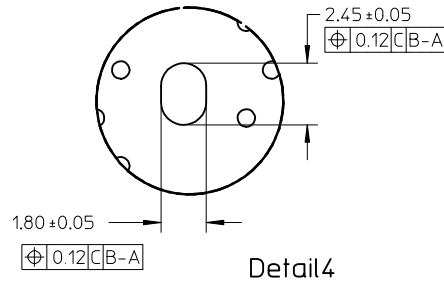
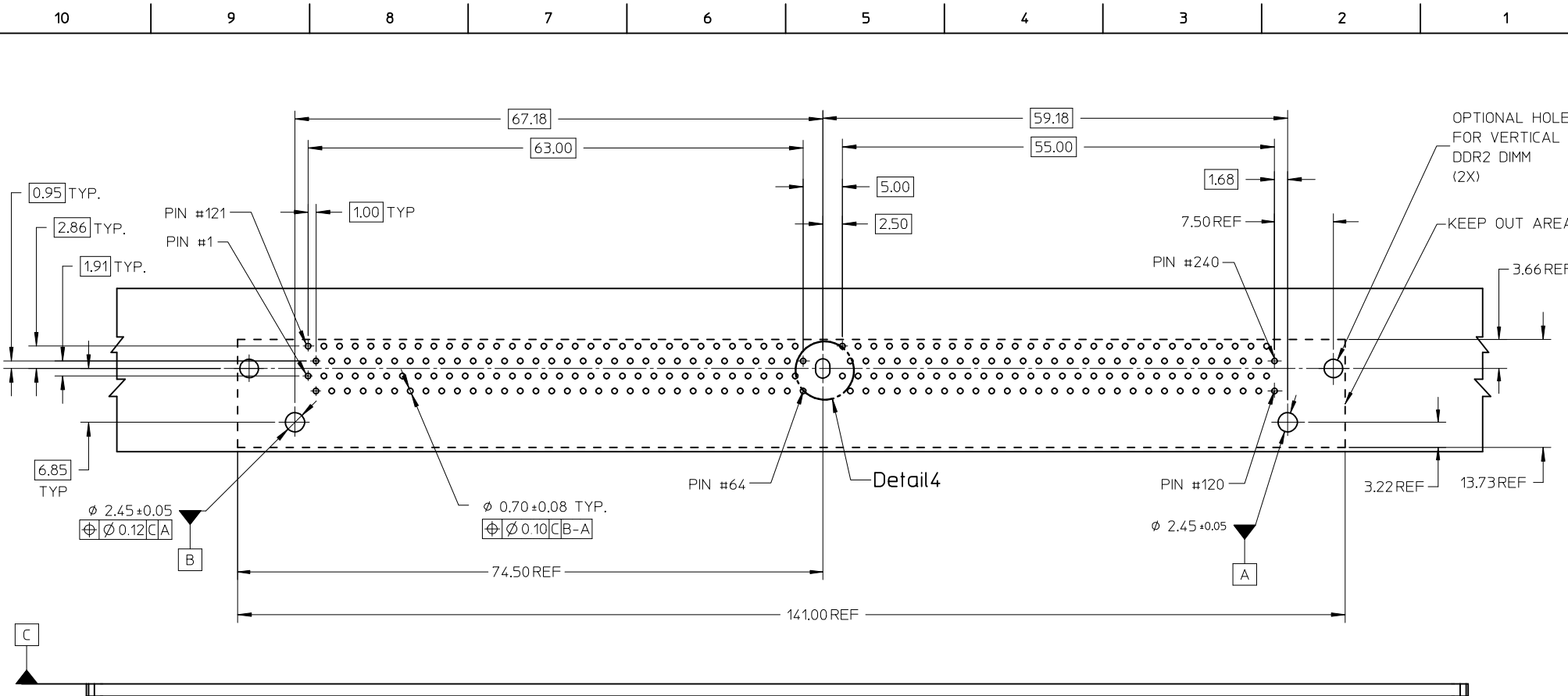

<b>ADDED OPTION</b> EC NO: S2009-0629 DRWN: CCTEH CHKD: CGTAN APPR: SHLENI	2009/03/27 2009/03/27 2009/03/27	QUALITY SYMBOLS ▽=0 ▽=0	GENERAL TOLERANCES (UNLESS SPECIFIED)		DIMENSION STYLE <b>MM ONLY</b>		SCALE <b>NTS</b>	DESIGN UNITS <b>METRIC</b>	THIRD ANGLE PROJECTION		
				4 PLACES ± --- ± --- 3 PLACES ± --- ± --- 2 PLACES ± 0.25 ± --- 1 PLACE ± --- ± ---	mm    INCH	DRAWN BY MLONG	DATE 2004/03/25	TITLE <b>DDR2 DIMM, 1.00MM PITCH          240 CKTS, 25 DEG.</b>			
				ANGULAR ± 5 °	DRAFT WHERE APPLICABLE MUST REMAIN WITHIN DIMENSIONS		CHECKED BY SRRAMESH	DATE 2004/03/26	MOLEX INCORPORATED		
						MATERIAL NO. <b>SEE TABLE</b>	APPROVED BY GGLEE	DATE 2004/03/26	DOCUMENT NO. <b>SD-87803-010</b>	SHEET NO. <b>4 OF 5</b>	

PART NO.	VOLTAGE KEY	DIM 'P'	DIM 'Q'	RECOMMENDED PCB THICKNESS	CONTACT AREA PLATING	SOLDERTAIL PLATING	LUBRICATION
87803-0002	1.8V	2.79	3.18	1.57	0.38µM/ 15µ" GOLD OVER 1.27µM/ 50µ" MIN NICKEL	2.54µM/ 100µ" MIN, TIN (MATTE) OVER 1.27µM/ 50µ" MIN NICKEL	NO
87803-0022							YES
87803-0012		3.18	4.83	2.36			NO
87803-0032							YES
87803-0052		4.00	3.18	NO			
87803-0062				YES			
87803-0102		2.79	3.18	1.57	0.76µM/ 30µ" GOLD OVER 1.27µM/ 50µ" MIN NICKEL		NO
87803-0122							YES
87803-0112		3.18	4.83	2.36			NO
87803-0132							YES
87803-0152		4.00	3.18	NO			
87803-0162				YES			

ADDED OPTION EC NO: S2009-0629 DRWN: CCTE CH'KD: GTAN APPR: SILENI 2009/03/27 2009/03/27 2009/03/27	QUALITY SYMBOLS	GENERAL TOLERANCES (UNLESS SPECIFIED)	DIMENSION STYLE	SCALE	DESIGN UNITS	THIRD ANGLE PROJECTION
	▼=0 ◻=0	mm    INCH 4 PLACES ± --- ± --- 3 PLACES ± --- ± --- 2 PLACES ± 0.25 ± --- 1 PLACE ± --- ± --- ANGULAR ± 5 °	MM ONLY	NTS	METRIC	
	DESCRIPTION	DRAFT WHERE APPLICABLE MUST REMAIN WITHIN DIMENSIONS	DRAWN BY: MLONG    DATE: 2004/03/25 CHECKED BY: SRRAMESH    DATE: 2004/03/26 APPROVED BY: GGLEE    DATE: 2004/03/26	TITLE: DDR2 DIMM, 1.00MM PITCH 240 CKTS, 25 DEG.		
	REV: B1		SEE TABLE	MOLEX INCORPORATED DOCUMENT NO. SD-87803-010		SHEET NO. 5 OF 5