

DETAILS

Product Number	C13805_STRADA-2X2-T4
Family	Strada
Type	Lens
Color	clear
Diameter	50x50 mm
Height	7,7 mm
Style	square
Optic Material	PMMA
Holder Material	
Fastening	pin, screw
Status	production ready
ROHS Compliant	Yes
Date Updated	20/12/2017



OPTICAL PROPERTIES

LED	Viewing Angle	Light Beam	Efficiency	cd/lm	Connector
XM-L	Asymmetric deg	Asymmetric	95 %	0.630	-
XP-G	Asymmetric deg	Asymmetric	94 %	0.500	-
XT-E	Asymmetric deg	Asymmetric	94 %	0.500	-
XP-L	Asymmetric deg	Asymmetric	94 %	0.520	-
XM-L2	sim: Asymmetric	Asymmetric	sim: 94 %	-	-
XP-L HI	Asymmetric deg	Asymmetric	94 %	0.560	-
XHP35 HD	sim: Asymmetric	Asymmetric	sim: 90 %	-	-
XHP35 HI	sim: Asymmetric	Asymmetric	sim: 93 %	-	-
XP-G2	Asymmetric deg	Asymmetric	94 %	0.570	-
XP-G3	Asymmetric deg	Asymmetric	94 %	0.600	-
XP-L2	Asymmetric deg	Asymmetric	94 %	0.540	-
H35C1 (LEMWA33)	Asymmetric deg	Asymmetric	94 %	0.600	-
LUXEON T	Asymmetric deg	Asymmetric	95 %	0.600	-
LUXEON Q	Asymmetric deg	Asymmetric	94 %	0.600	-
LUXEON MZ	Asymmetric deg	Asymmetric	94 %	0.640	-
LUXEON TX	Asymmetric deg	Asymmetric	94 %	0.590	-
LUXEON V	Asymmetric deg	Asymmetric	94 %	0.560	-
NVSxx19B/NVSxx19C	sim: Asymmetric	Asymmetric	sim: 94 %	sim: 0.603	-
NVSW3x9A	Asymmetric deg	Asymmetric	94 %	0.640	-
Oslon Square PC	Asymmetric deg	Asymmetric	94 %	0.600	-
Oslon Square Gen3	sim: Asymmetric	Asymmetric	sim: 92 %	sim: 0.510	-
Duris S8	sim: Asymmetric	Asymmetric	sim: 93 %	sim: 0.500	-
OSCONIQ P 3737 (2W version)	sim: Asymmetric	Asymmetric	sim: 93 %	sim: 0.570	-
OSCONIQ P 3737 (3W version)	sim: Asymmetric	Asymmetric	sim: 94 %	sim: 0.500	-
Duris S5 (2 chip)	sim: Asymmetric	Asymmetric	sim: 94 %	sim: 0.540	-



PRODUCT DATASHEET

Strada series

last update 20/12/2017

OPTICAL PROPERTIES

LED	Viewing Angle	Light Beam	Efficiency	cd/lm	Connector
PrevaLED Brick DC 2x8	sim: Asymmetric	Asymmetric	sim: 92 %	sim: 0.510	-
Fortimo FastFlex LED board 2x8 DA G4	Asymmetric deg	Asymmetric	sim: 94 %	0.580	-
Fortimo FastFlex LED board 2x8 DAX G4	Asymmetric deg	Asymmetric	94 %	sim: 0.000	-
LH351B	Asymmetric deg	Asymmetric	sim: 94 %	0.600	-
LH351D	sim: Asymmetric	Asymmetric	sim: 91 %	sim: 0.480	-
Z8Y22P	Asymmetric deg	Asymmetric	94 %	0.630	-
Z8Y22	Asymmetric deg	Asymmetric	94 %	0.690	-
TL1L4	Asymmetric deg	Asymmetric	91 %	0.590	-
RLE G1 49x223mm 4000lm xxx EXC OT	Asymmetric deg	Asymmetric	94 %	0.600	-
RLE G1 49x245mm 4000lm xxx EXC OT	Asymmetric deg	Asymmetric	94 %	0.600	-
RLE G1 49x121mm 2000lm xxx EXC OT	Asymmetric deg	Asymmetric	94 %	0.600	-
RLE G1 49x133mm 2000lm xxx EXC OT	Asymmetric deg	Asymmetric	94 %	0.600	-

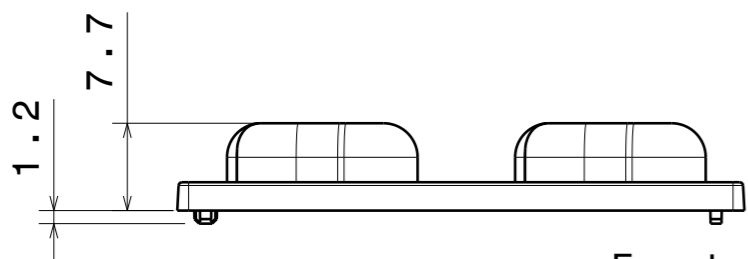

Front view
Scale: 3:2

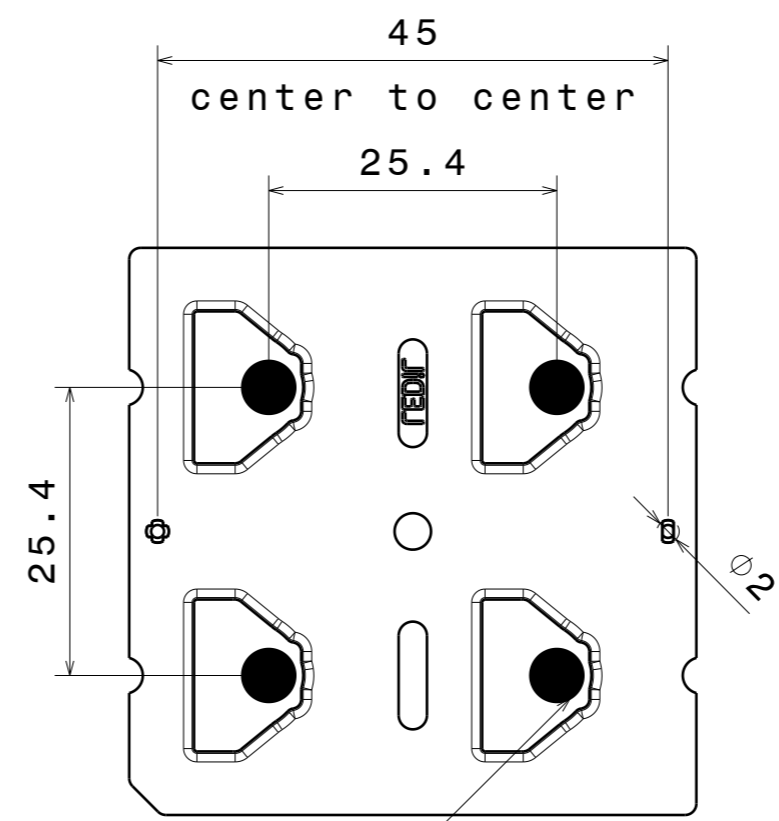

LED position Bottom view
Scale: 3:2

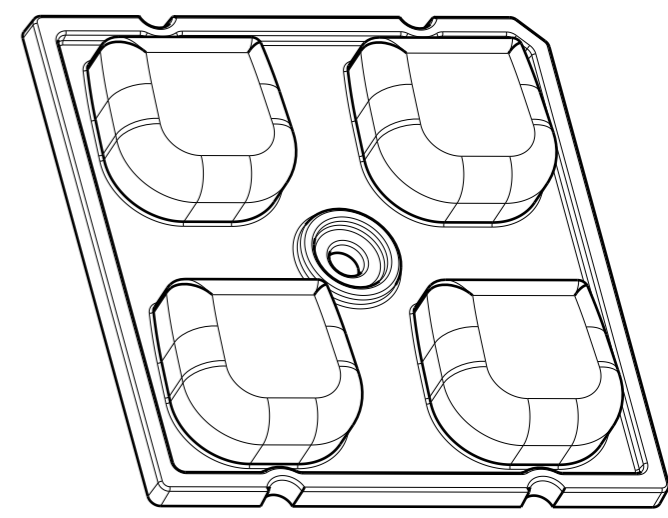

Isometric view
Scale: 3:2

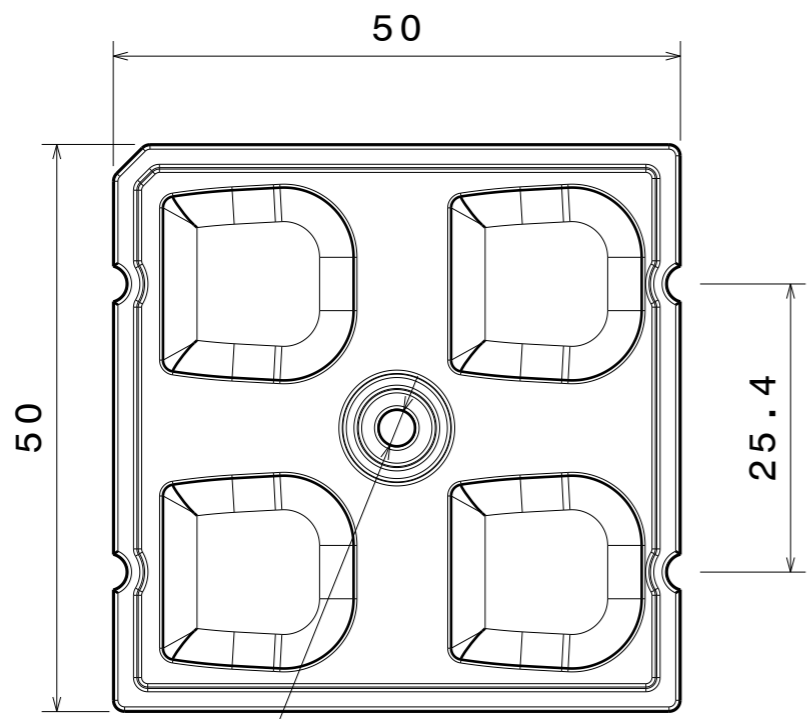

Top view
Scale: 3:2

INDEX	PART NO	DESCRIPTION	MATERIAL	COLOUR
1	C13805	STRADA-2X2-T4	PMMA	

Tolerances if not otherwise shown
According to DIN ISO 2768-1
Linear measures:
Up to 30mm class M, otherwise class C.
According to DIN ISO 2768-2
Form and position: class L

LEDiL LediL Oy
Salorankatu 10
FIN 24240 SALO
Finland

THIRD ANGLE PROJECTION:

DRAWING TITLE
C13805_STRADA-2X2-T4

This drawing is the property of LEDiL Oy. It may not be reproduced, copied or communicated without a written agreement with LEDiL Oy."

SIZE	PART NUMBER
A3	C13805

SCALE	3:2	WEIGHT	-	SHEET	1/1
-------	-----	--------	---	-------	-----

Luminaire: LEDiL Oy C13805_STRADA-2X-T4 (XM-L)_4 Eff.94.8%
Lamps: 1 x CREE_XM-L_2x2_354.749lm@250mA_P=2.82762W_I=249.9mA

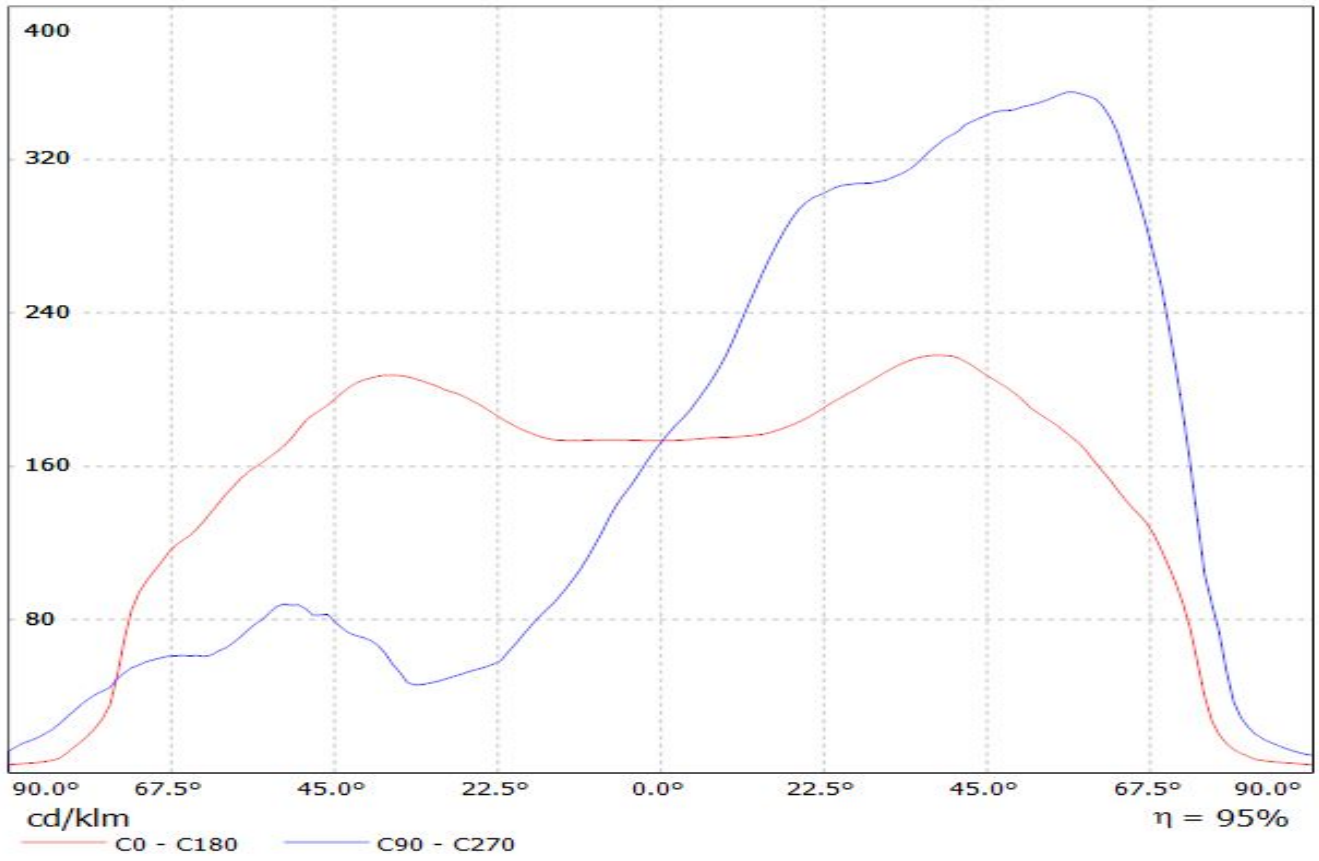

LEDiL Oy C13805_STRADA-2X2-T4_(XP-G) Eff.94.0% / LDC (Linear)

Luminaire: LEDiL Oy C13805_STRADA-2X2-T4_(XP-G) Eff.94.0%
Lamps: 1 x CREE_XP-G_2x2_254.292lm@250mA_P=2.89709W_I=249.9mA

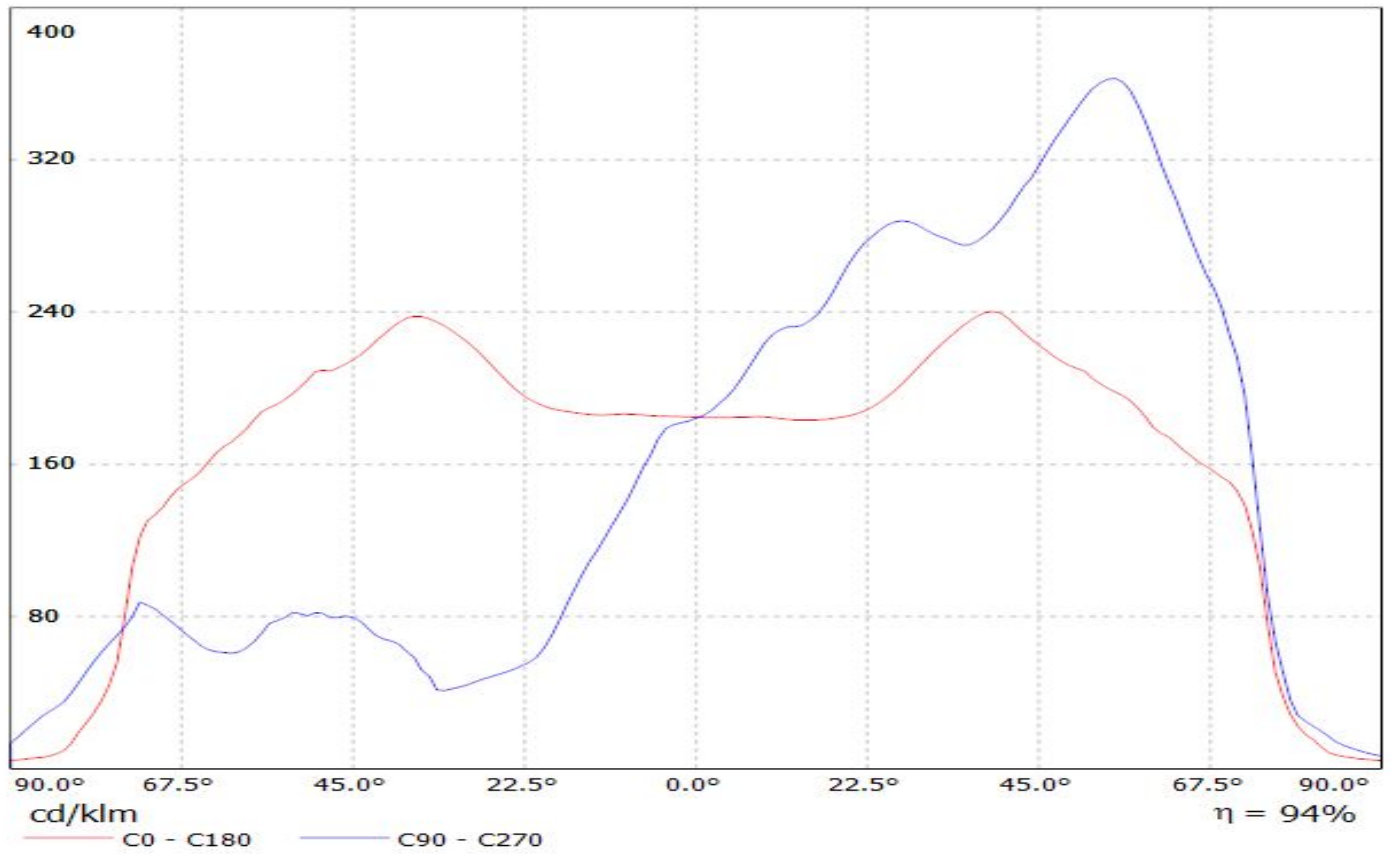

LEDiL Oy C13805_STRADA-2X2-T4_(XT-E) Eff.94.0% / LDC (Linear)

Luminaire: LEDiL Oy C13805_STRADA-2X2-T4_(XT-E) Eff.94.0%

Lamps: 1 x CREE_XT-E_2x2_381.369lm@250mA_CCT=5717K_P=2.9868W_I=249.9mA

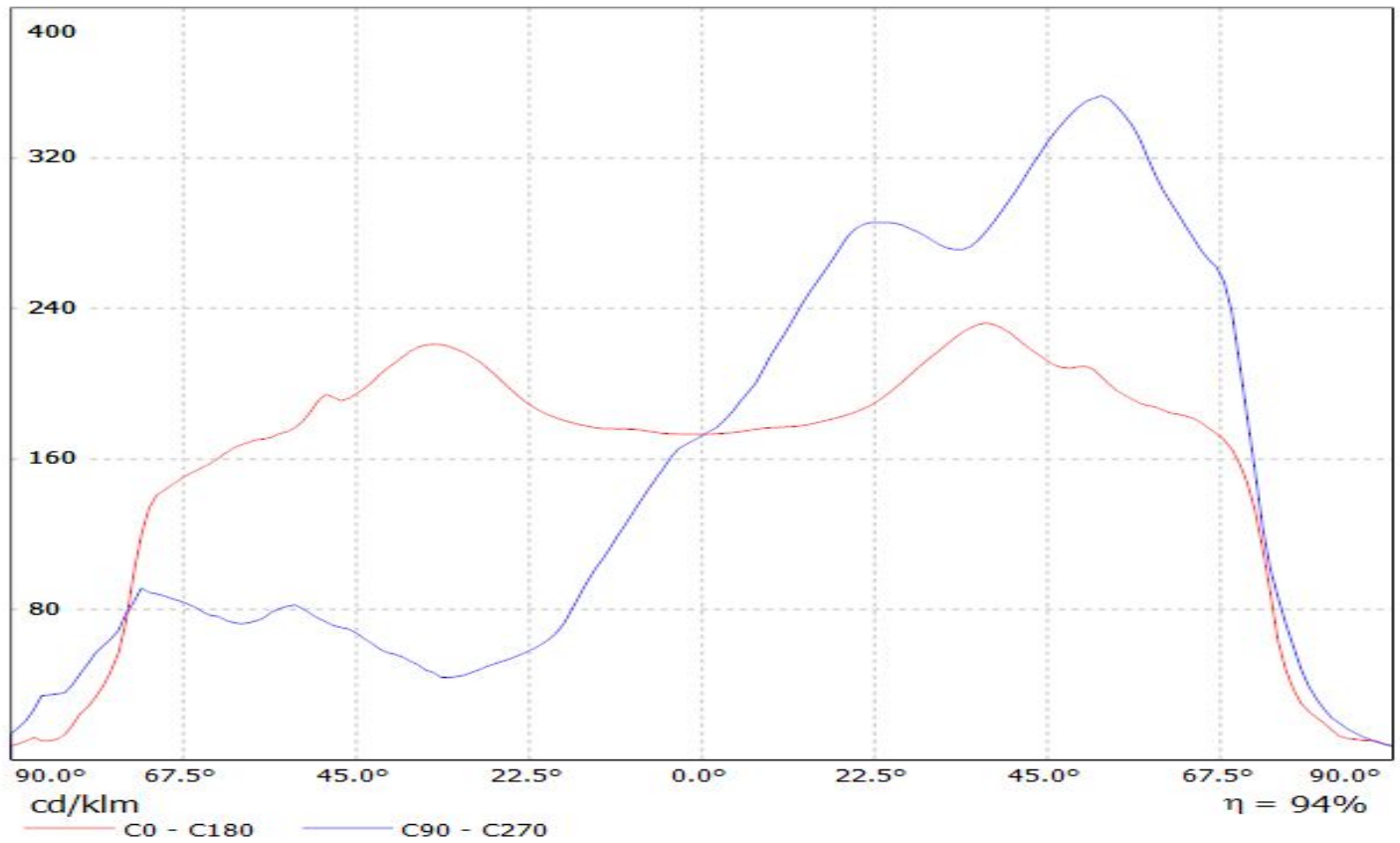

Luminaire: LEDiL Oy C13805_STRADA-2x2-T4_(XP-L)

Lamps: 1 x CREE_XP-L_2x2_(XPLAWT-0-1B0-V40-00-0001)_515lm@250mA_CCT=7600K_P=2.79963W_I=249.9mA

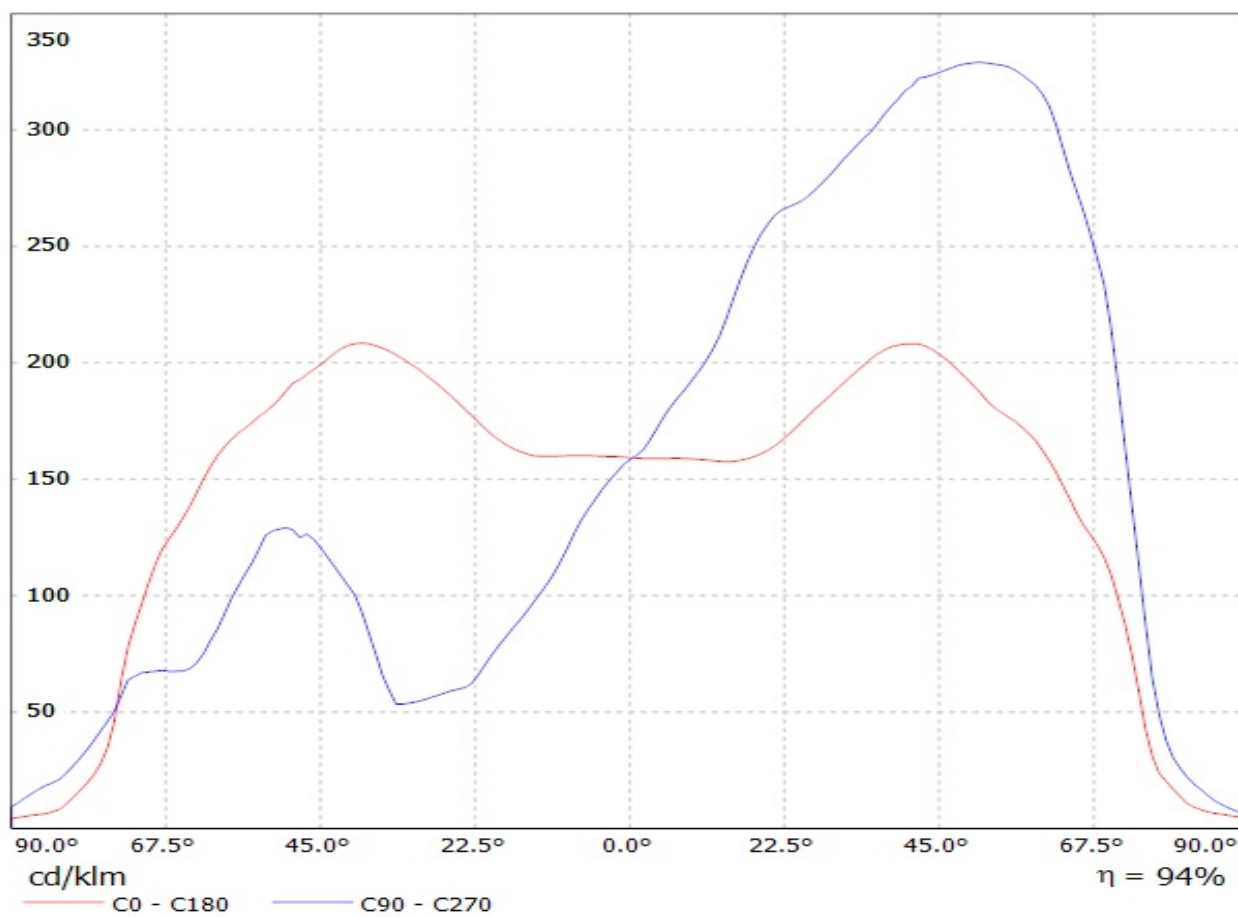

Luminaire: LEDiL Oy C13805_STRADA-2X2-T4_(XP-L_HI)
Lamps: 1 x Cree_XP-L_HI_(2x2)_(XPLAWT-H-5A3-U60-013-0001)
_455.077lm@250mA_P=2.84011W_I=0.2499A

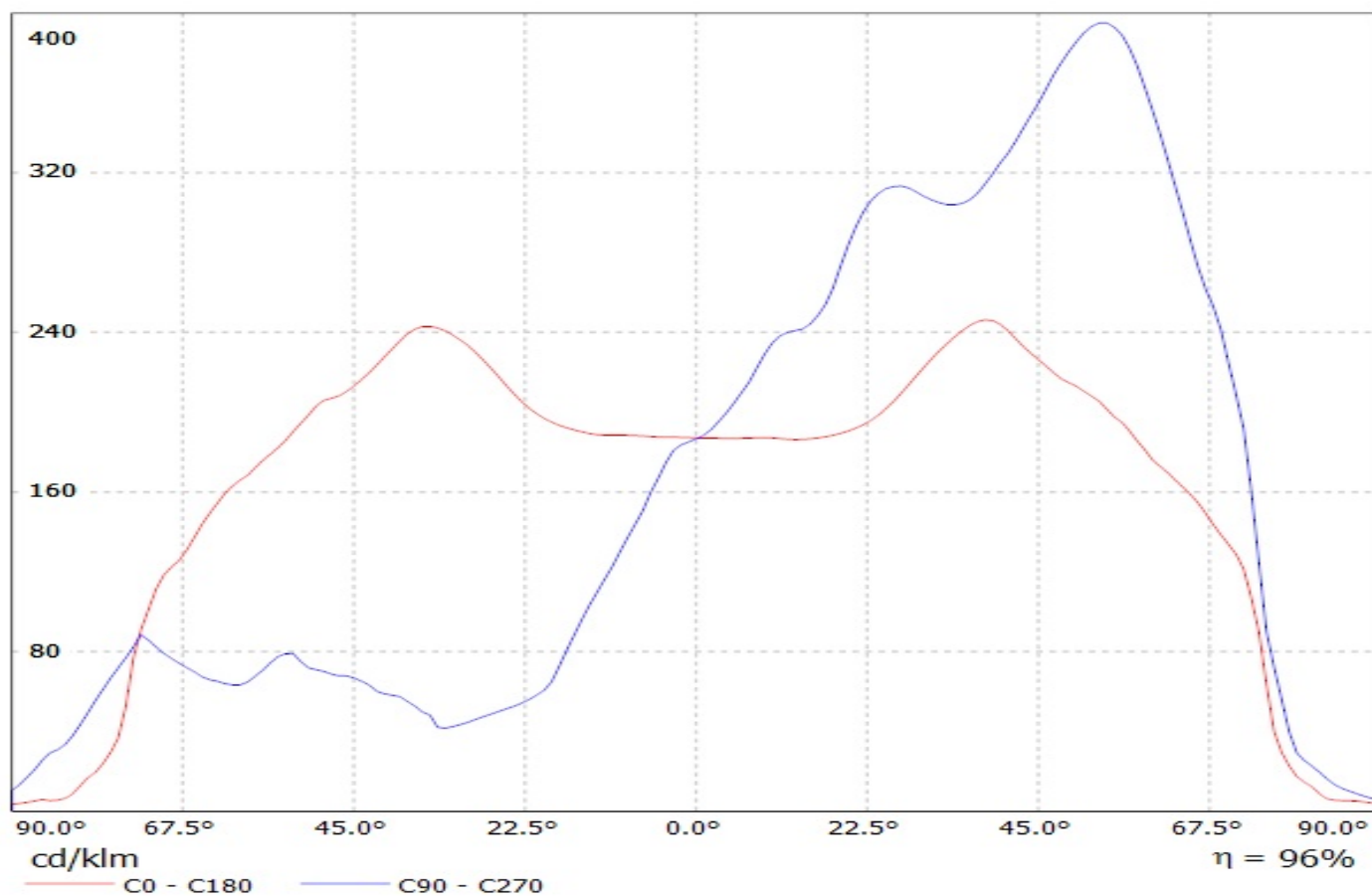

Luminaire: LEDiL Oy C13805_STRADA-2X2-T4_(XP-G2)
Lamps: 1 x Cree_XP-G2_(XPGBWT-L1-000-00-G51)_409.462lm@250mA_P=2.94407_I=0.250A

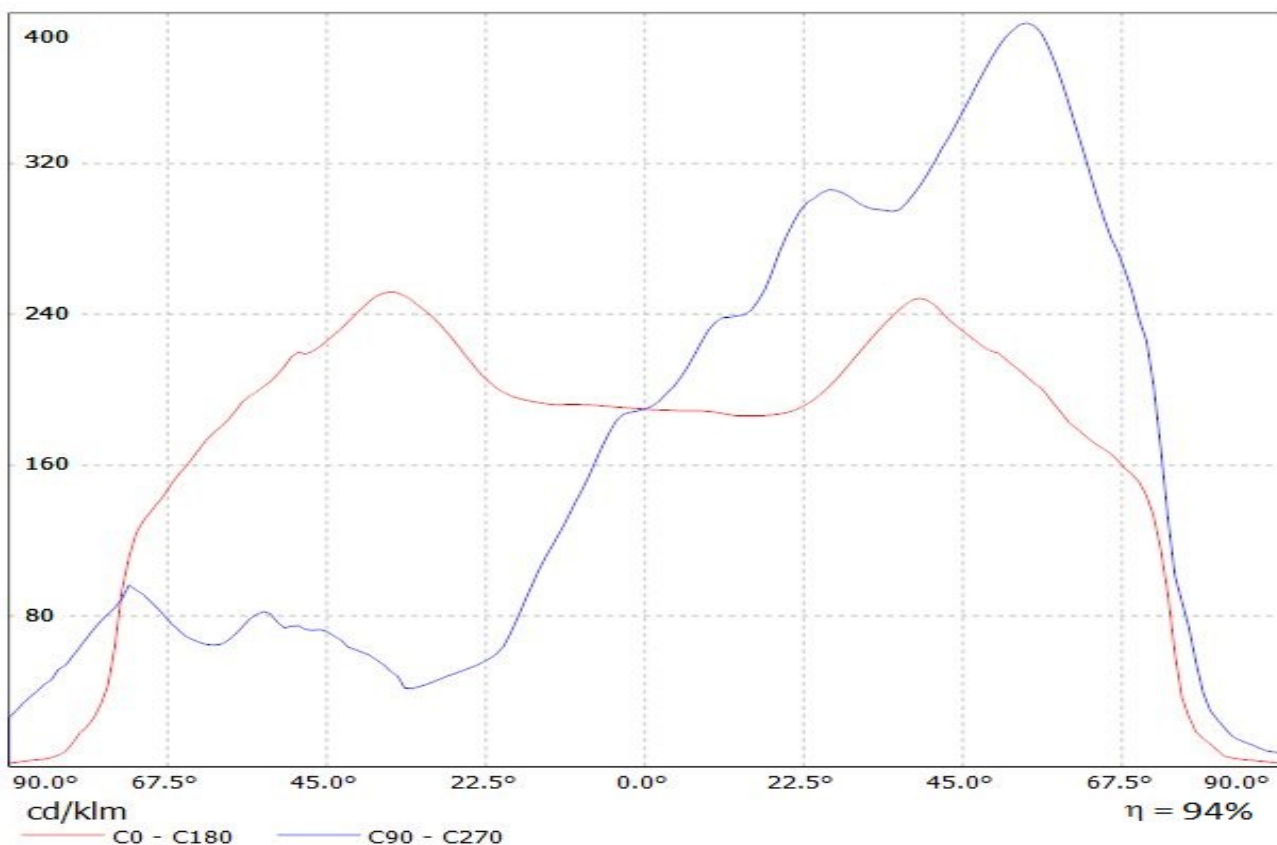

Luminaire: Ledil C13805_STRADA-2X2-T4_(XP-G3)

Lamps: 1 x Cree_XP-G3_2x2_(XPGDWT-B1-3C0-S4-0-01)_516.212lm@250mA_P=2.78875W_I=0.250A

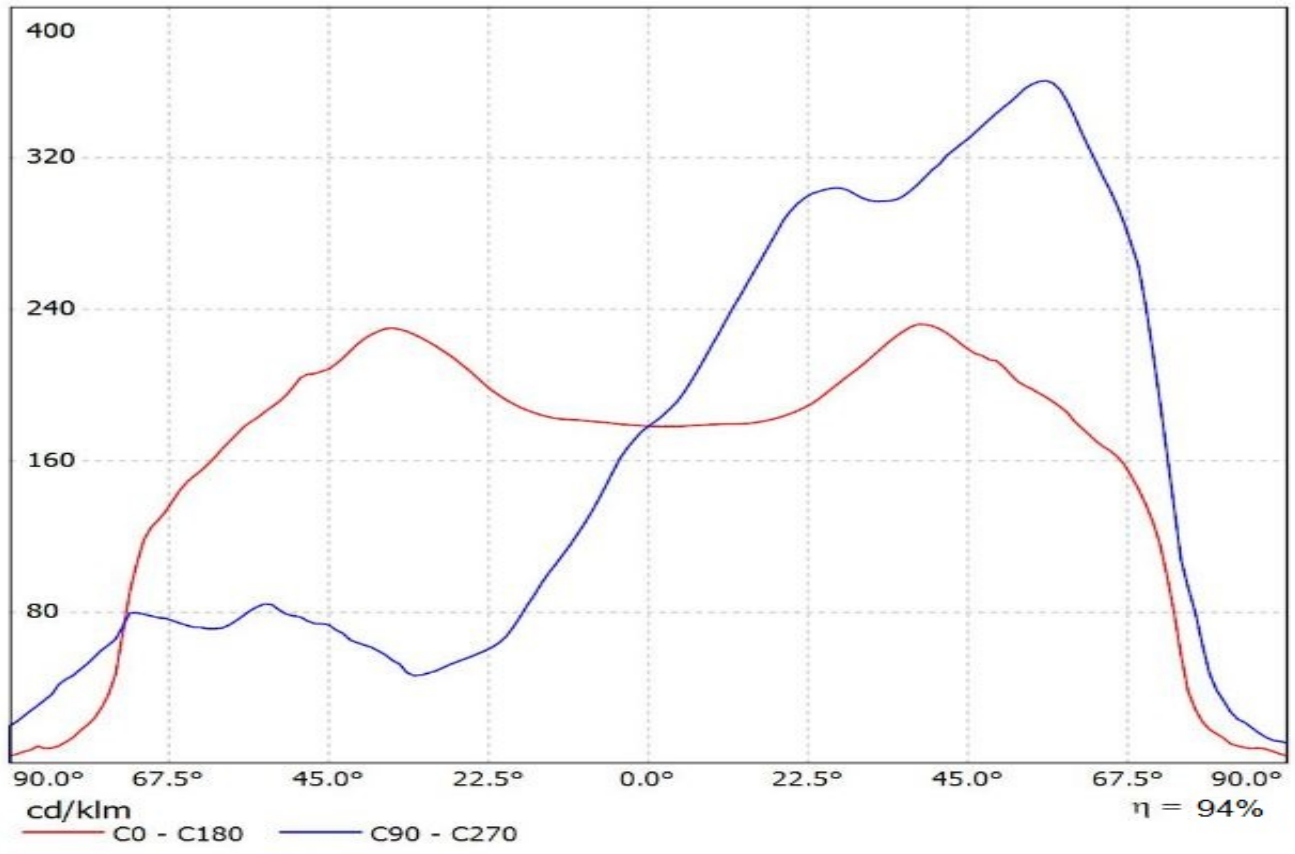

Luminaire: Ledil C13805_STRADA-2X2-T4_(XP-L2)

Lamps: 1 x Cree_XP-L2_2x2_(XPLBWT-00-0000-000BV50E3)550.93lm@250mA_P=2.7815W_η=0.25A

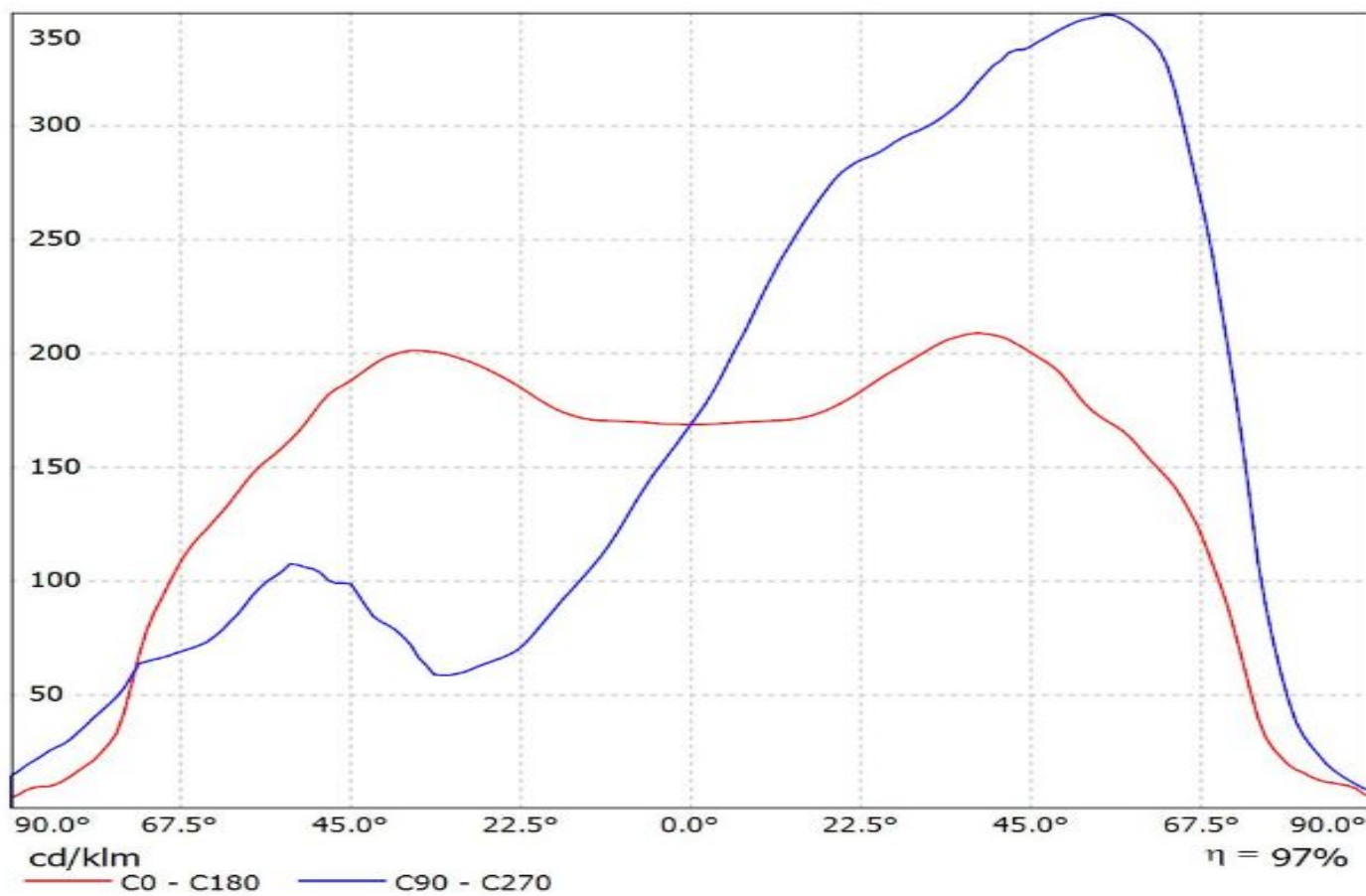

Luminaire: Ledil C13805_STRADA-2X2-T4_(H35C1)
Lamps: 1 x LG_H35C1_2x2_477.216lm@250mA_P=2.87475W_I=0.250A

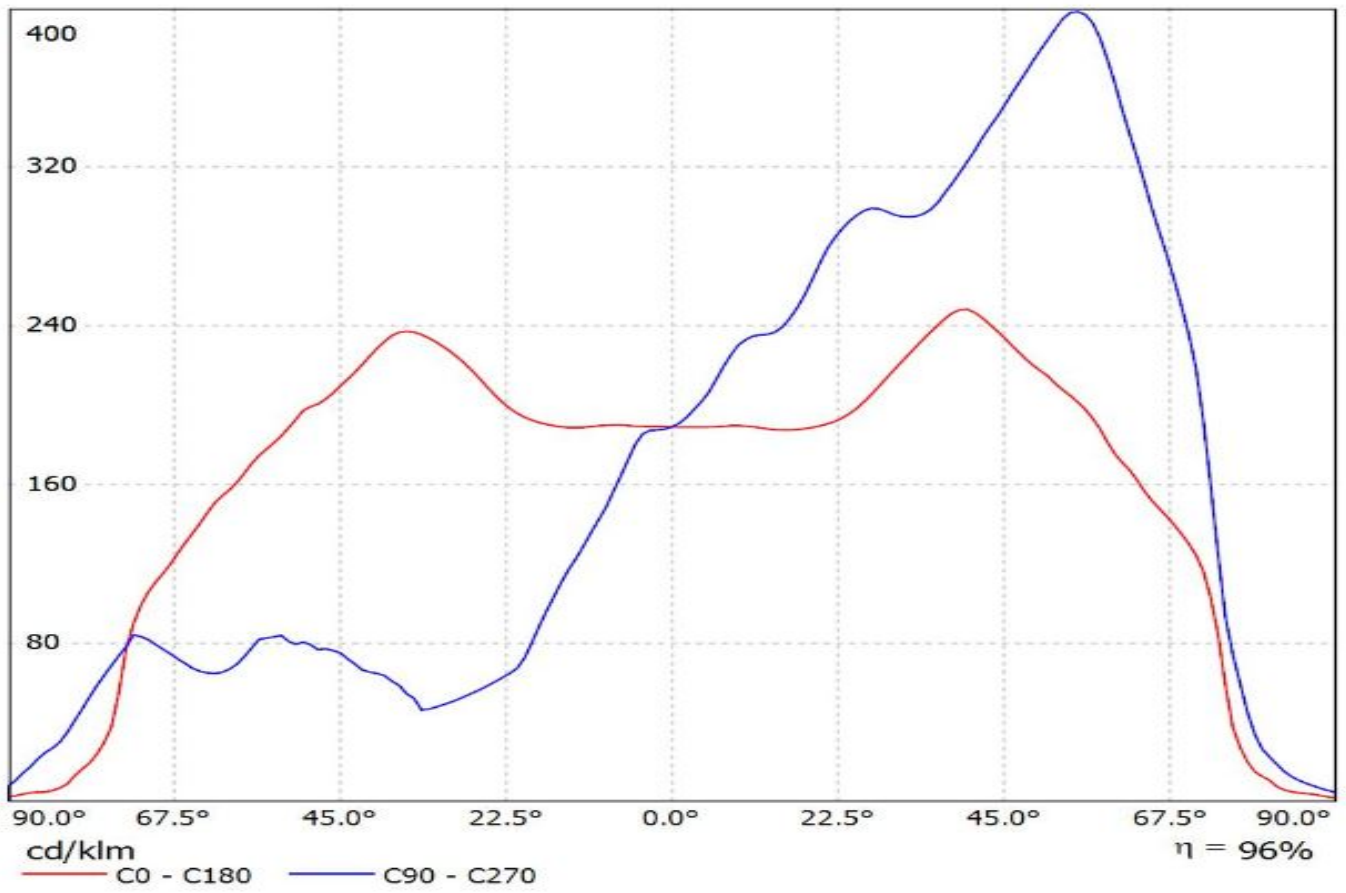

Luminaire: LEDiL Oy C13805_STRADA-2X2-T4_(LUXEON_T) Eff. 95%
Lamps: 1 x LUXEON_T_2x2_(LXH8-FW30-3)_293lm@250mA_CCT=3173K_P=2.79801W_I=249.8mA

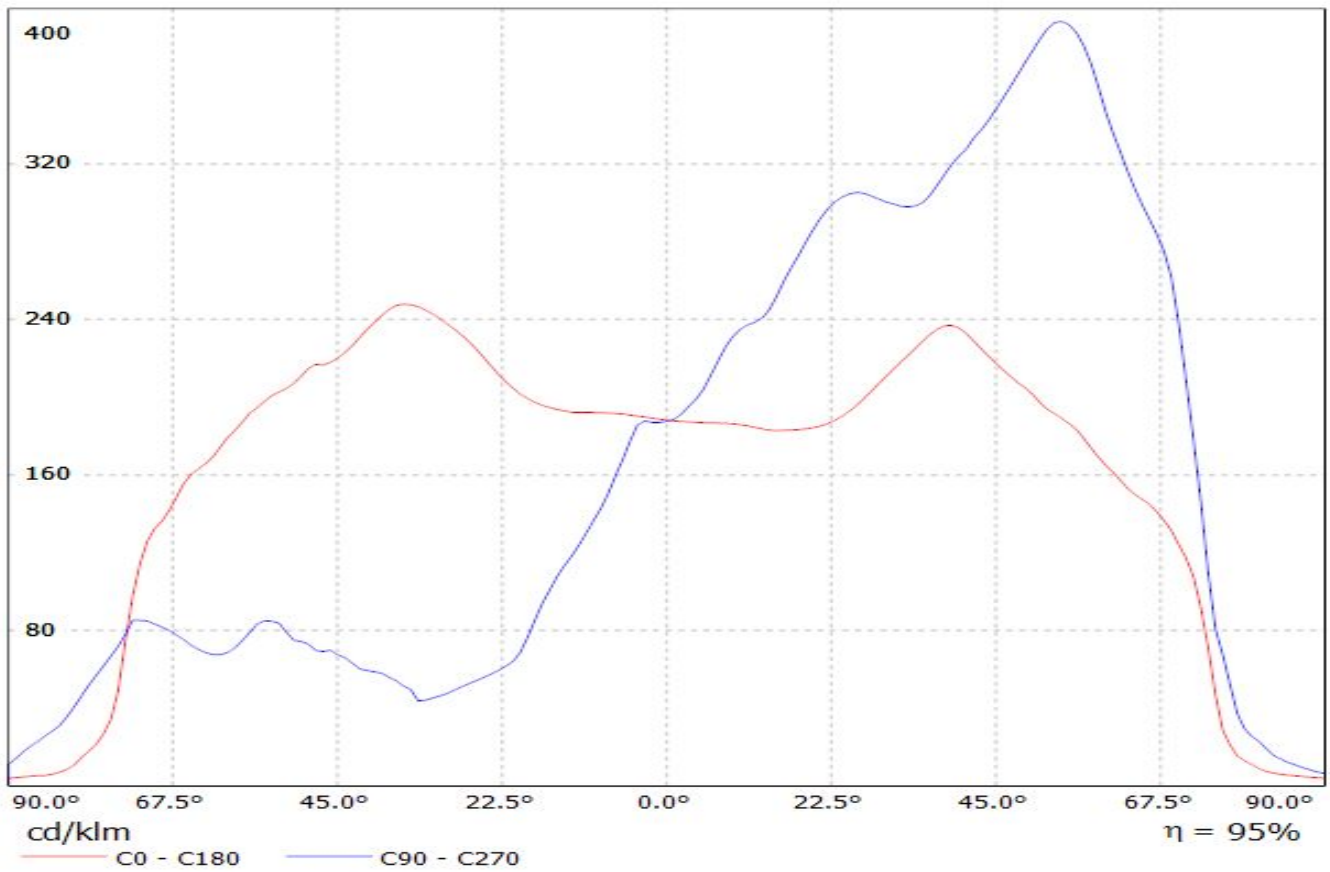

Luminaire: LEDiL Oy C13805_STRADA-2x2-T4_(LUXEON_Q)

Lamps: 1 x LUXEON_Q_2x2_(LHQ-3080)_299.038lm@250mA_P=2.8742W_I=249.8mA

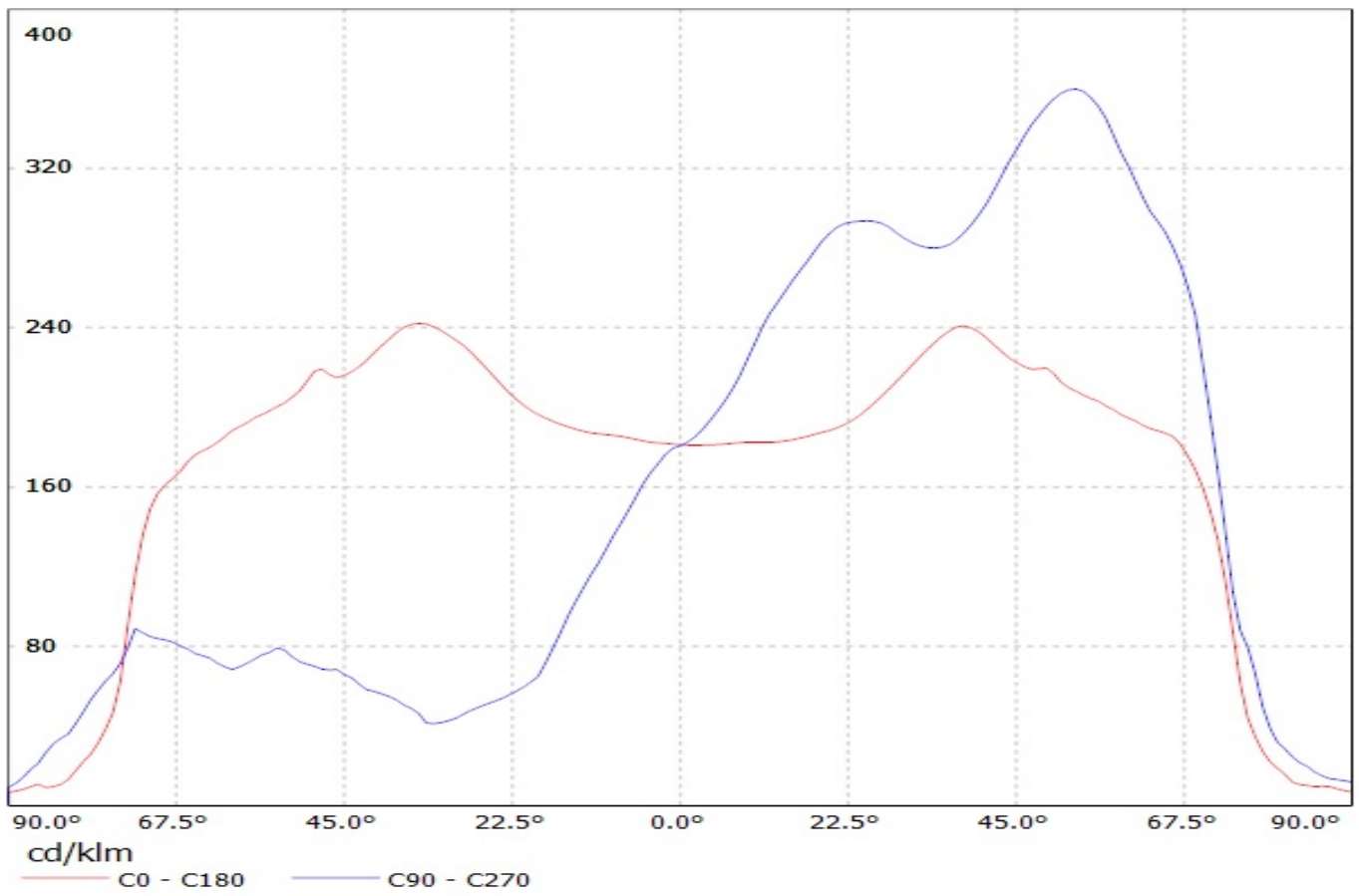

Luminaire: Ledil C13805_STRADA-2X2-T4_(Luxeon_MZ)

Lamps: 1 x Philips_Lumileds_Luxeon_MZ_(LMZ7-QW57)_(2x2)_427.268lm@250mA_P=2.734W_I=0.2500A

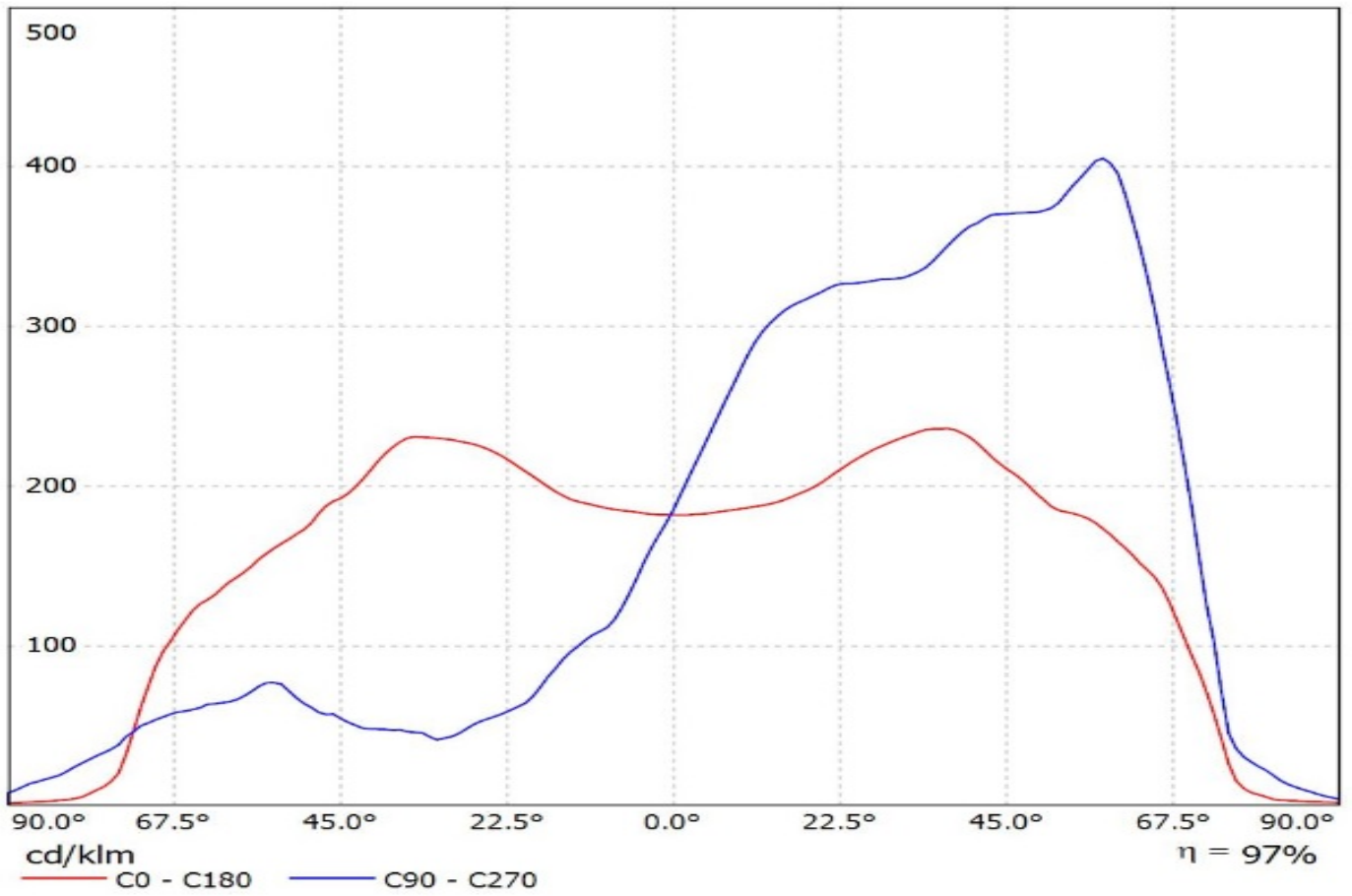

Luminaire: LEDiL Oy C13805_STRADA-2X2-T4_(Luxeon_TX)
Lamps: 1 x Luxeon_TX_2x2_321.384lm@250mA_P=2.79488W_I=249.9mA

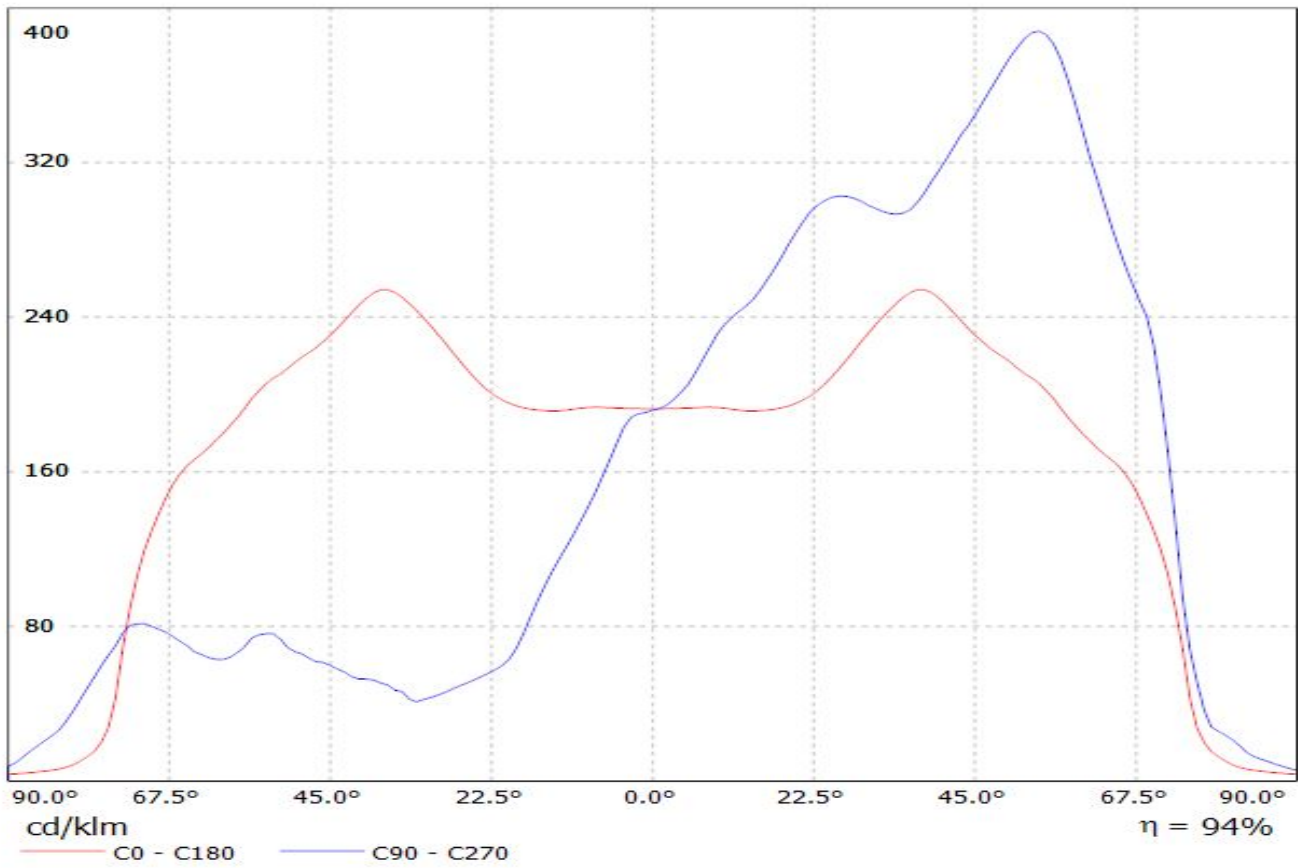

Luminaire: LEDiL Oy C13805_STRADA-2X2-T4_(Luxeon_V)

Lamps: 1 x Lumileds_Luxeon_V_488.501lm@250mA_CCT=4000K_P=2.75155W_I=0.250A

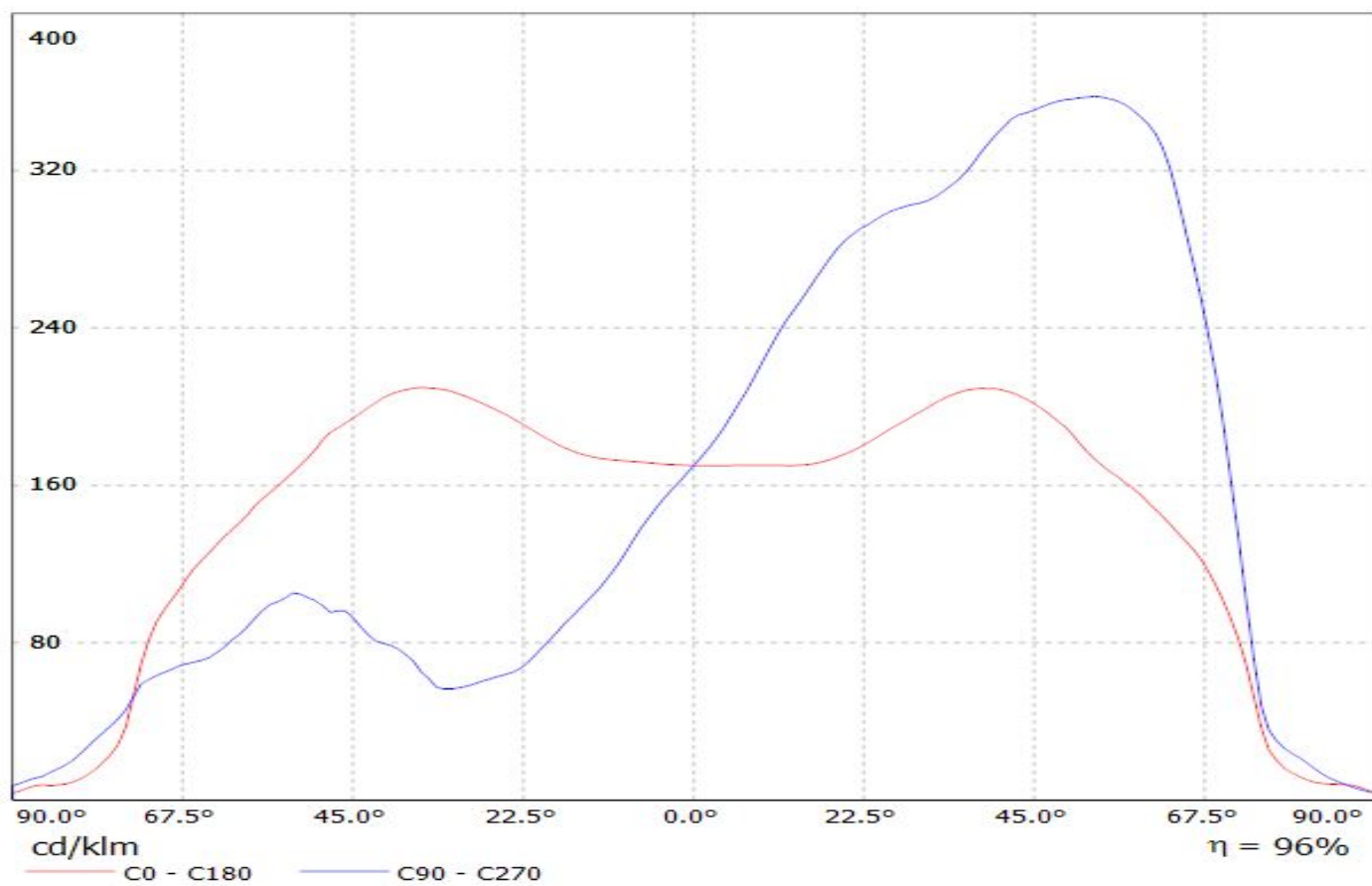

Luminaire: LEDiL Oy C13805_STRADA-2X2-T4_(NVSW319AE)
Lamps: 1 x Nichia_NVSW319AE_499.093lm@250mA_P=2.79052W_I=0.25A

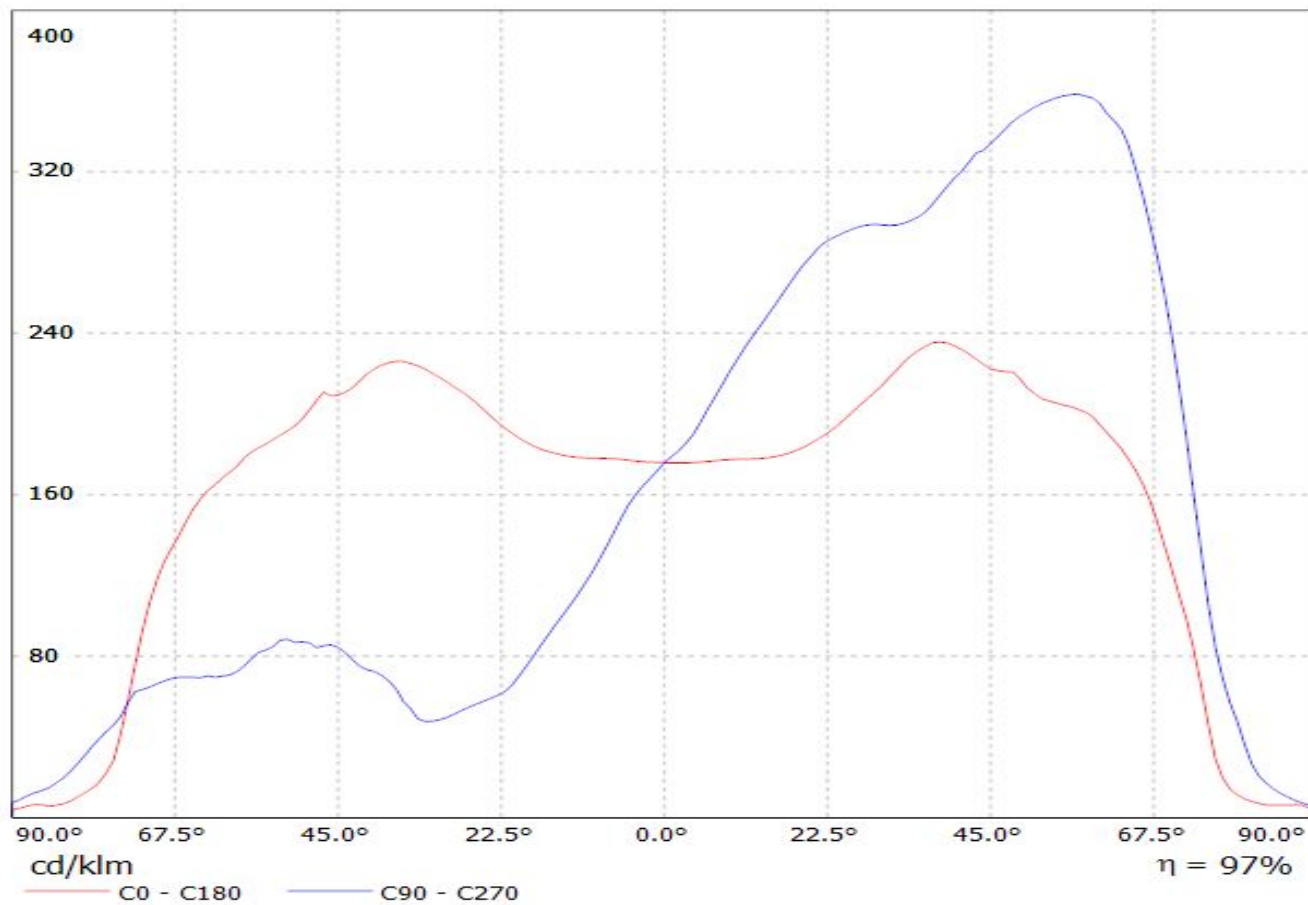

Luminaire: LEDiL Oy C13805_STRADA-2X2-T4_(Oslon_Square_PC_2x2)
Lamps: 1 x Osram_Oslon_Square_PC_2x2_(GWCSSRM1.PC)
_411.322lm@250mA_P=2.85186W_I=0,2499A

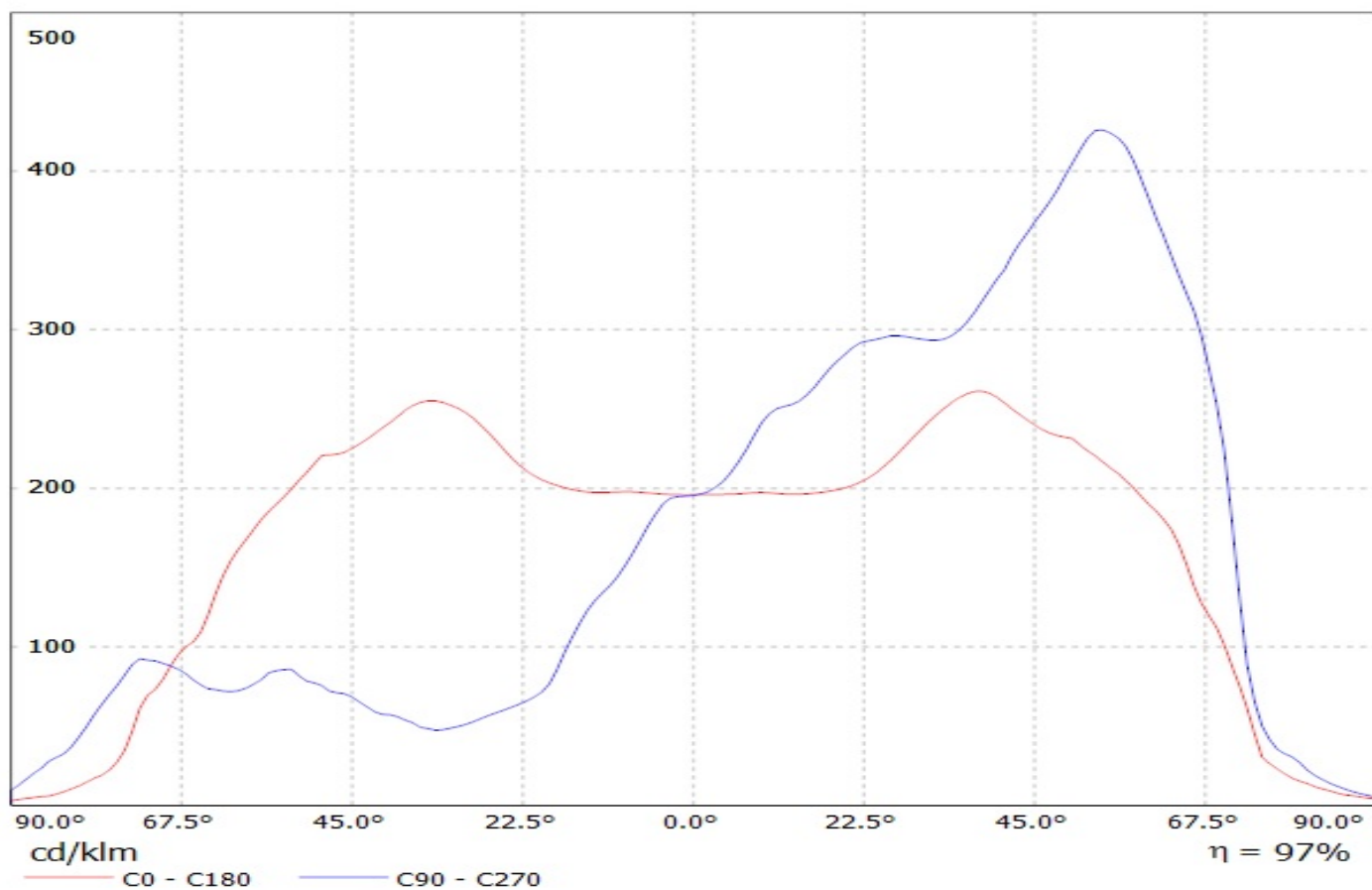

Luminaire: Ledil Oy C13805STRADA-2X2-T4_(Duris_S8_Gen2)_SIMULATED
Lamps: 1 x OSRAM_DURIS S8 GEN2 5050 package

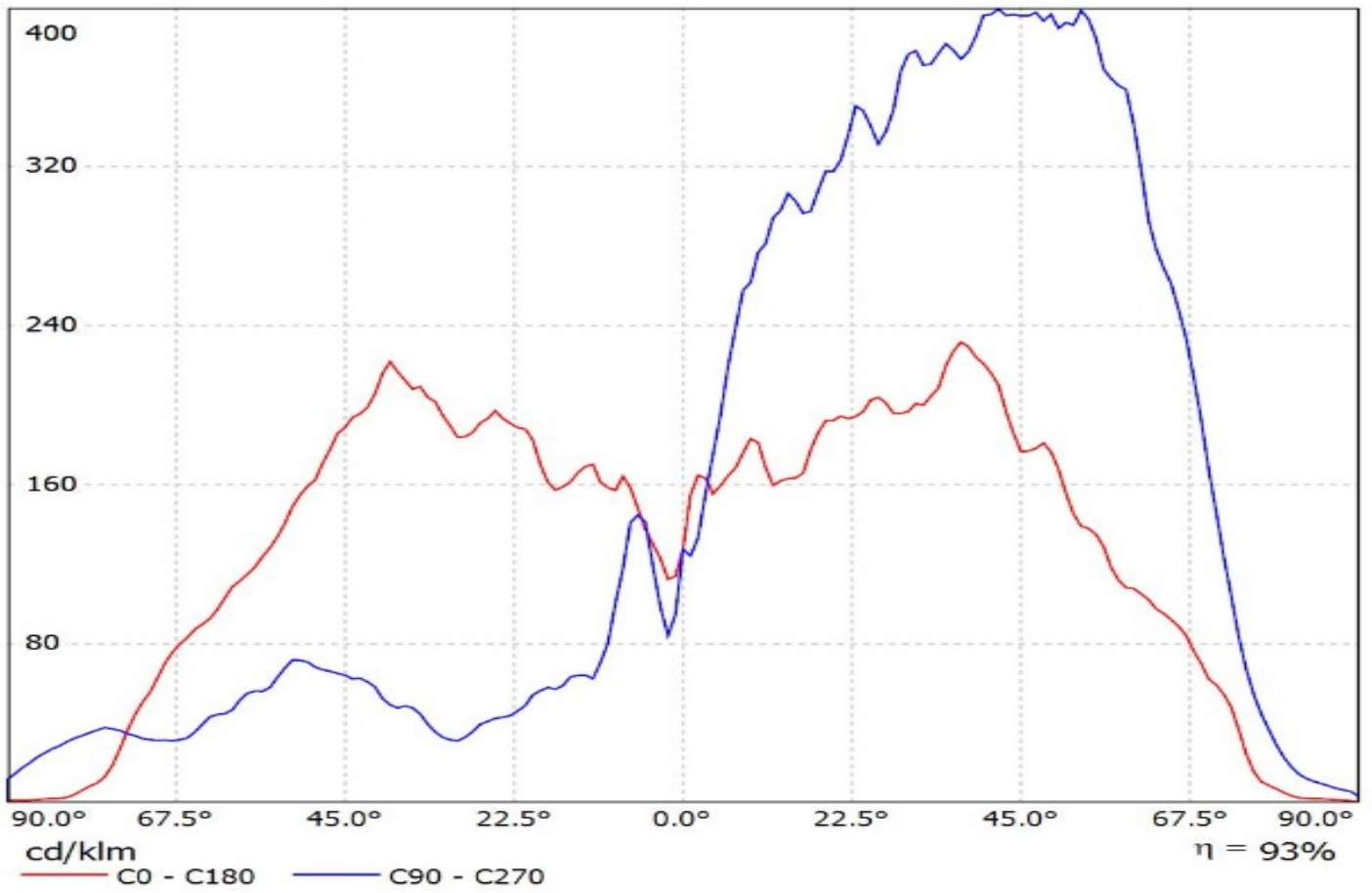

Luminaire: Ledil Oy C13805_STRADA-2X2-T4_(Duris_P8)_SIMULATED
Lamps: 1 x Osram Duris P8

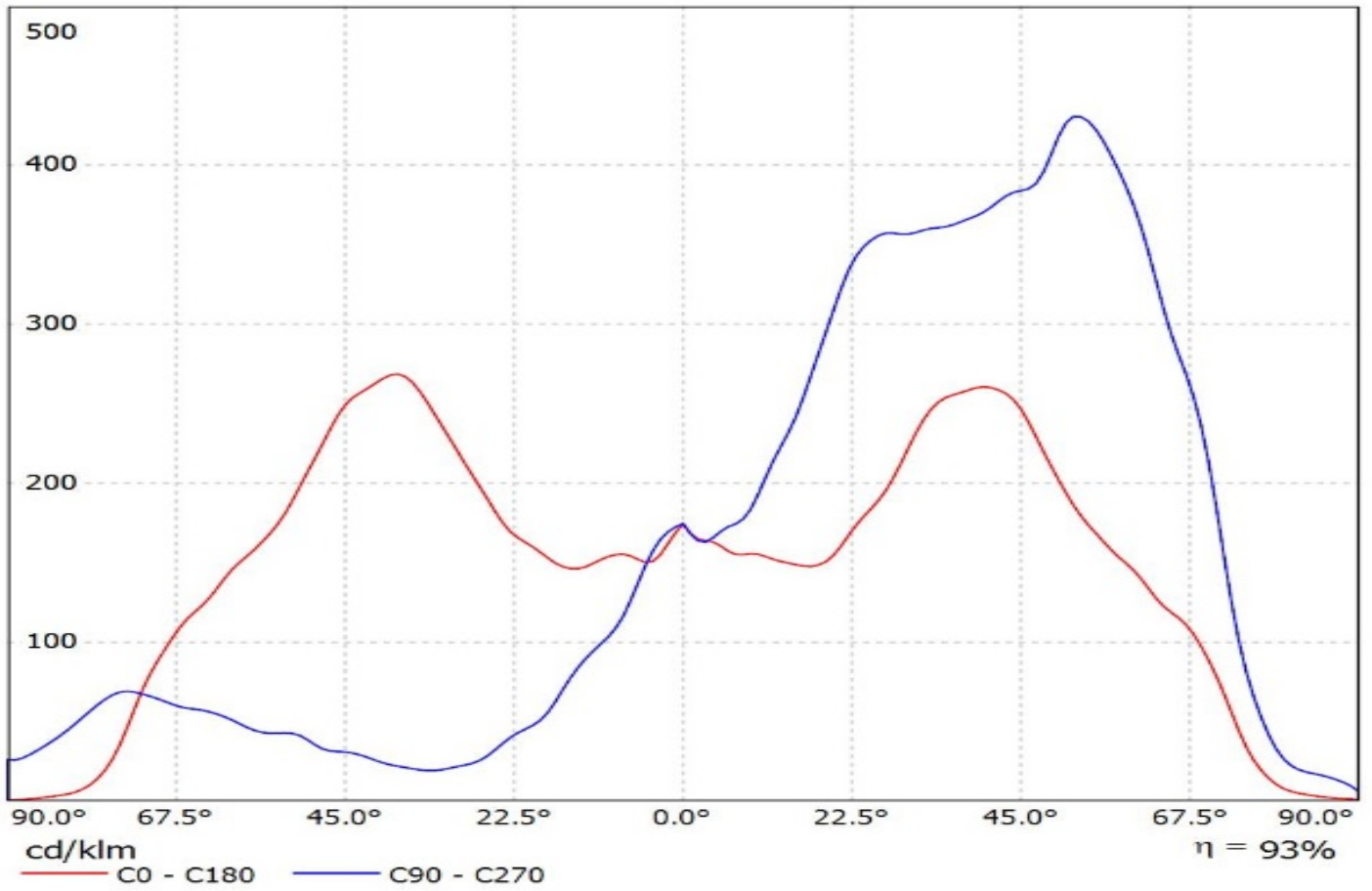

Luminaire: Ledil Oy C13805_STRADA-2X2-T4_OSRAM_DURIS_P9_SIMULATED
Lamps: 1 x OSRAM DURIS P9

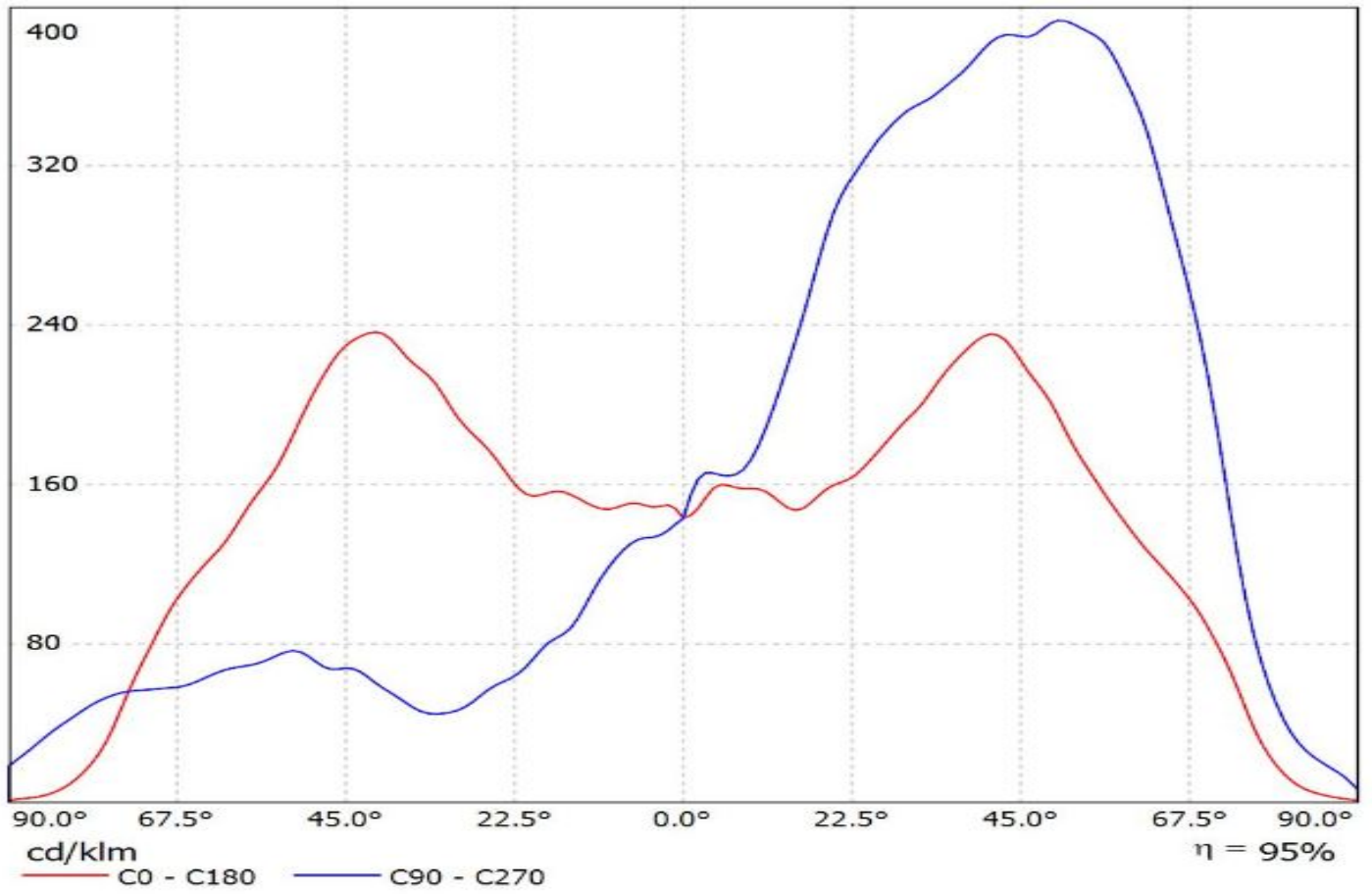

Luminaire: Ledil Oy C13805_STRADA-2X2-T4_(Duris S5 (2chip))_SIMULATED
Lamps: 1 x Osram Duris S5 2chip

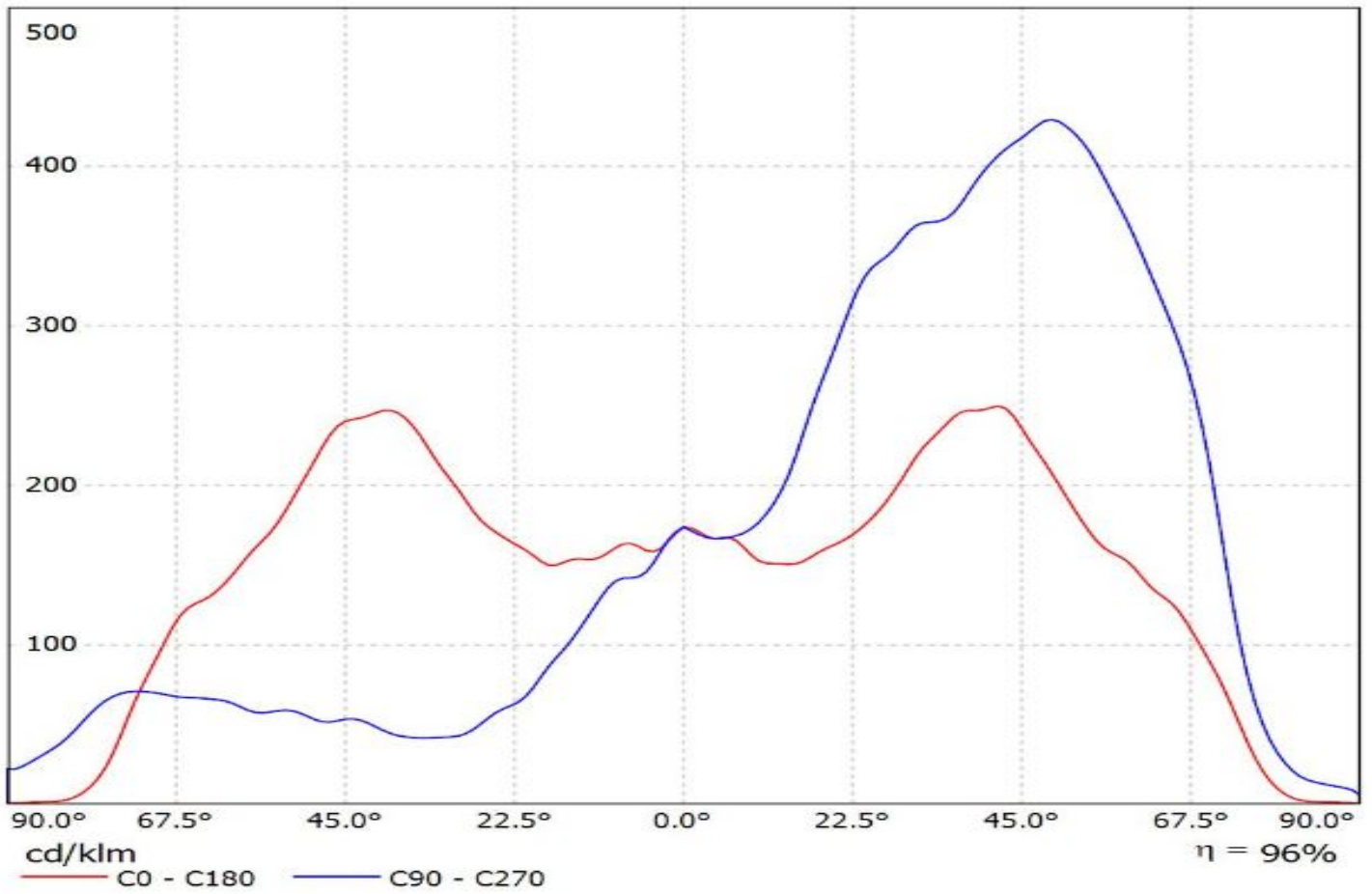

Luminaire: Ledil C13805_STRADA-2X2-T4 (Fortimo_FastFlex_LED_board_2x8/740_DA_G3)
Lamps: 1 x Fortimo_FastFlex_LED_board_2x8/740_DA_G3_1828.23lm@250mA_P=11.667W_η=0.25A

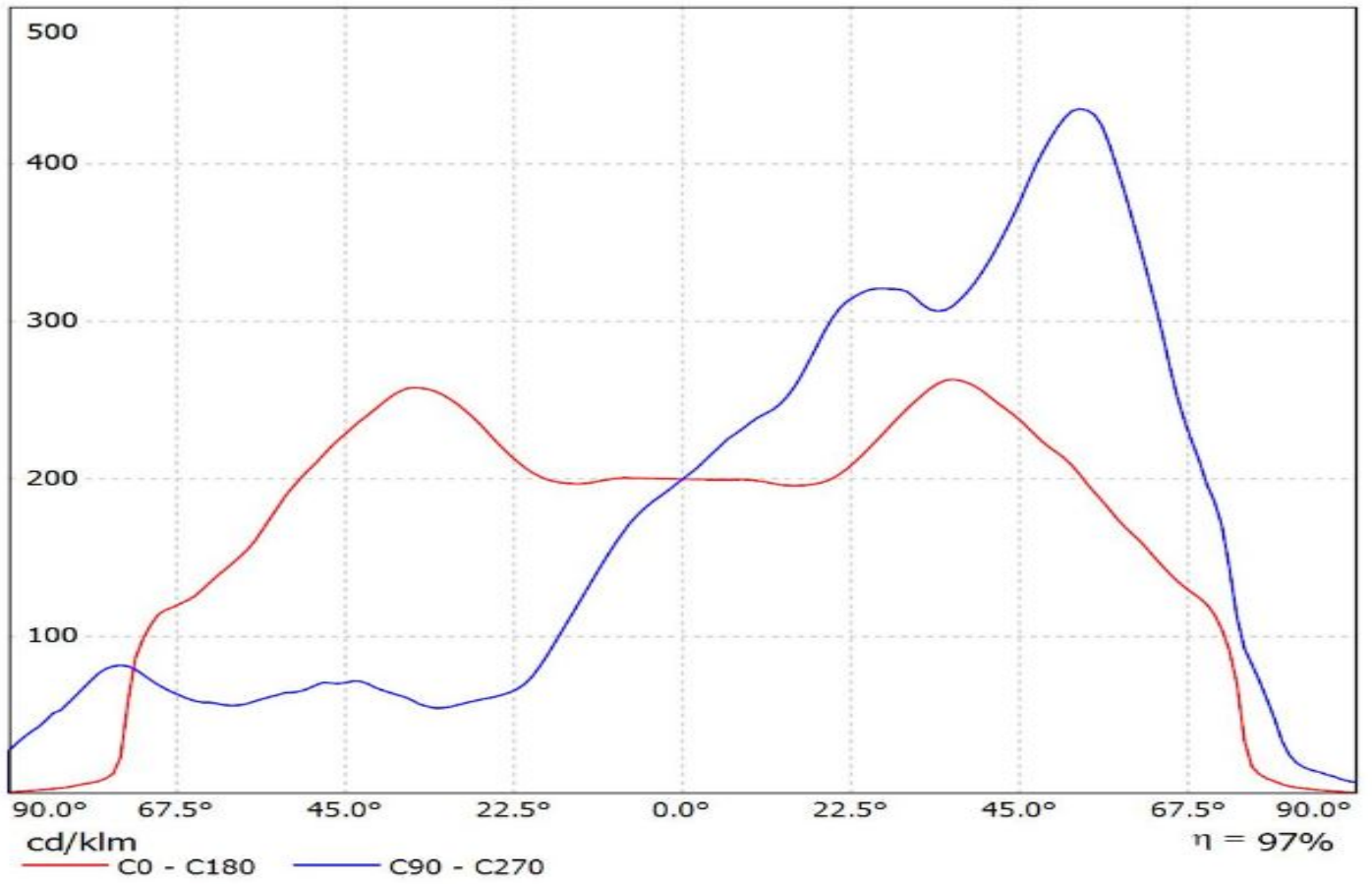

Luminaire: Ledil C13805_STRADA-2X2-T4_(Fortimo FastFlex LED board 2x8 DAX G4)
Lamps: 1 x Fortimo FastFlex LED board 2x8 DAX G4

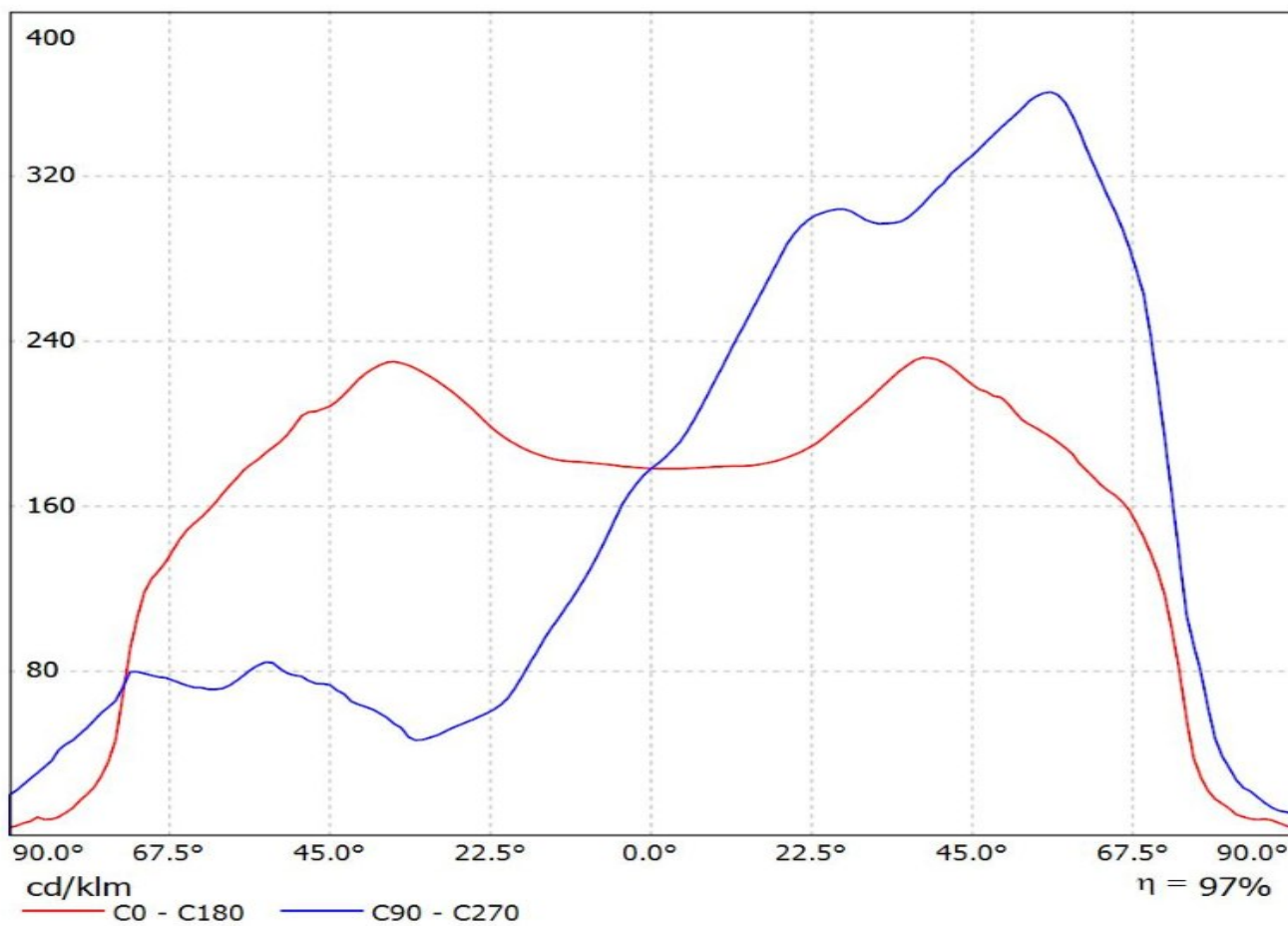

Luminaire: Ledil C13805_STRADA-2X2-T4_(LH351B)

Lamps: 1 x Samsung_LH351B_2x2_444.178lm@250mA_P=2.8535W_I=0.25A

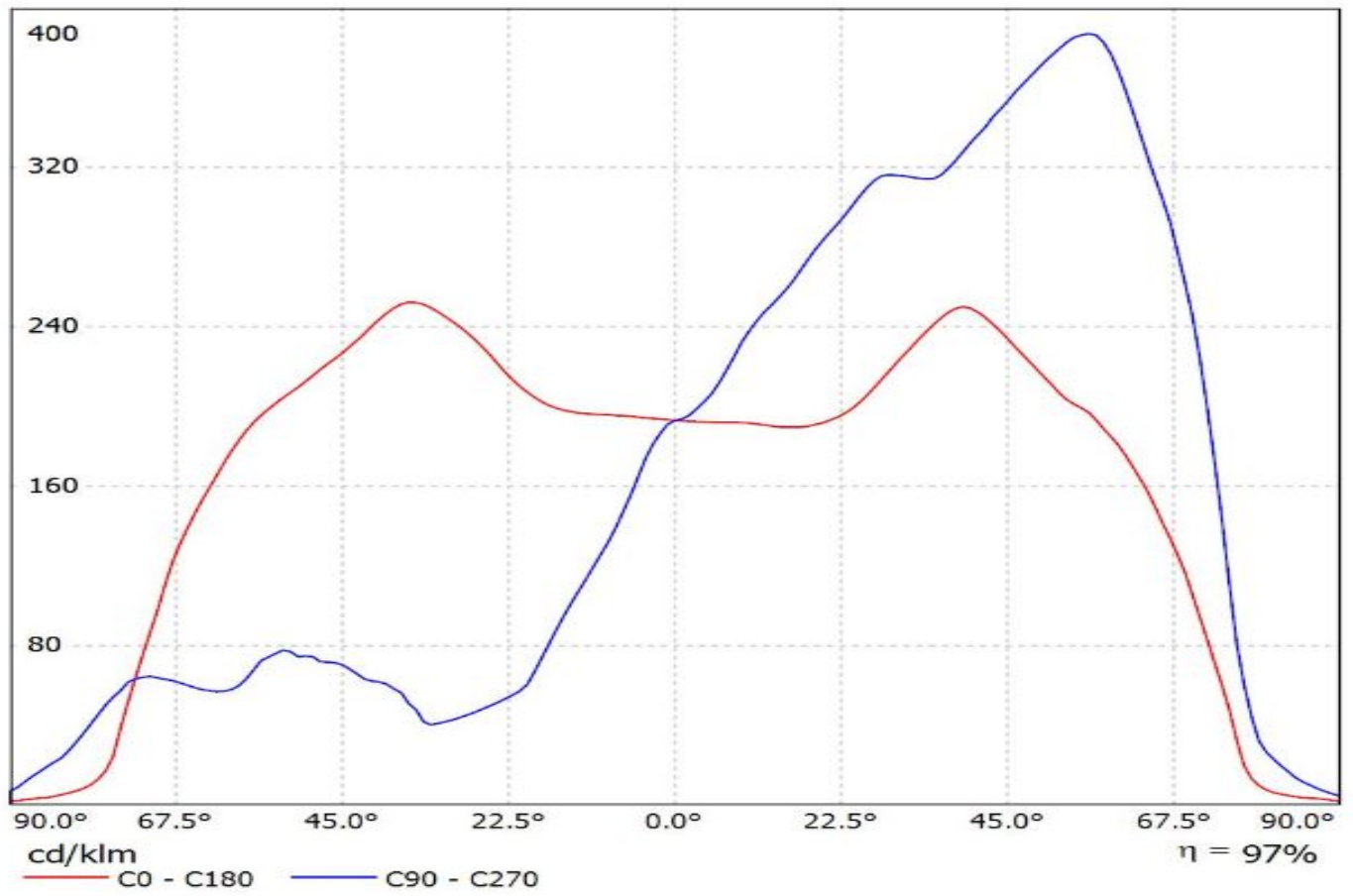

Luminaire: Ledil C13805_STRADA-2X2-T4_(Z8Y22plus)

Lamps: 1 x Seoul_Z8Y22plus_(W6E2G)_513.996lm@250mA_P=2.754W_I=0.250A

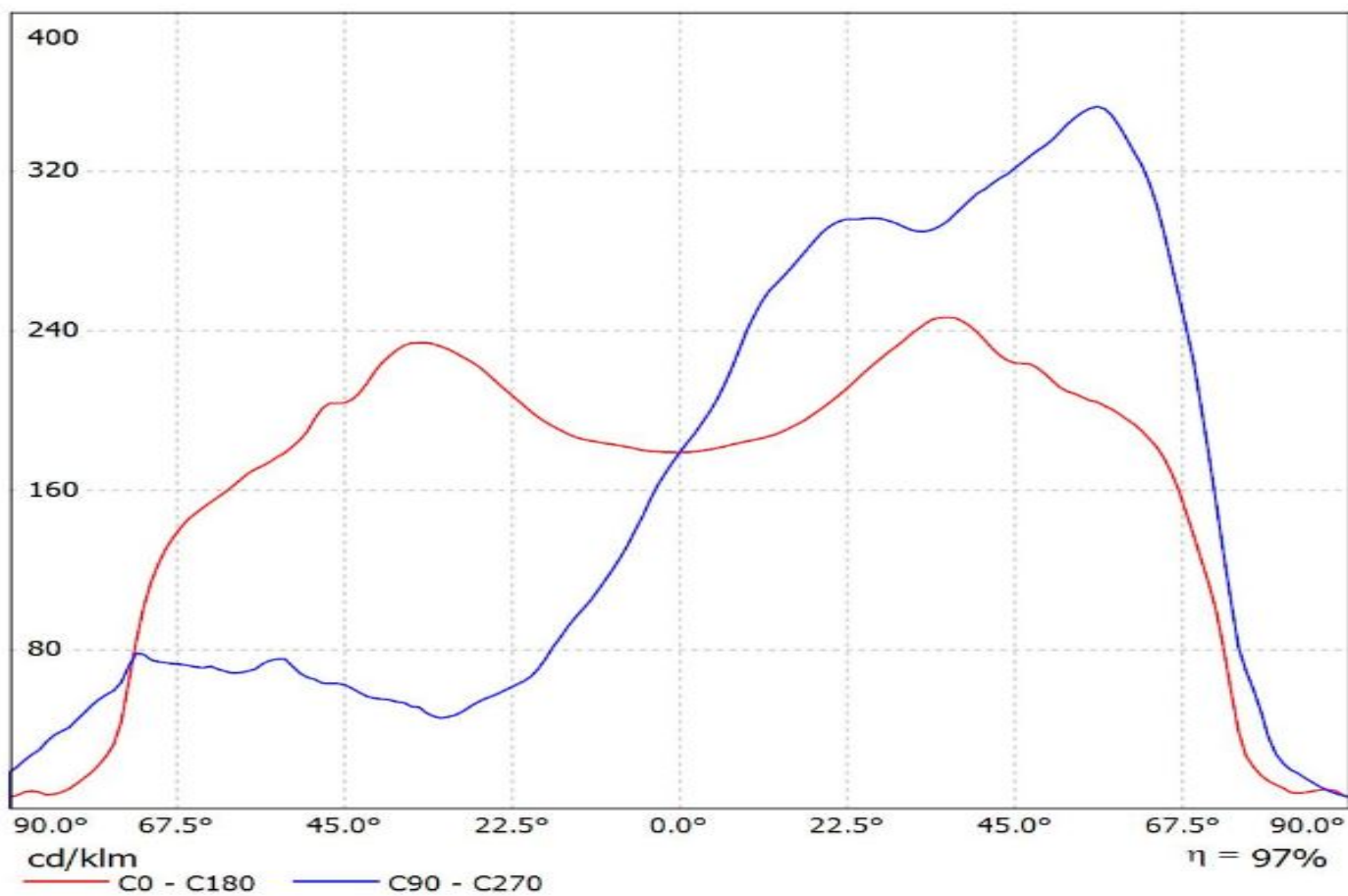

Luminaire: LEDiL Oy C13805_STRADA-2X2-T4_(Z8Y22)

Lamps: 1 x Seoul_Wicop_Z8Y22_497.373lm@250mA_P=2.80076W_U=11.211V

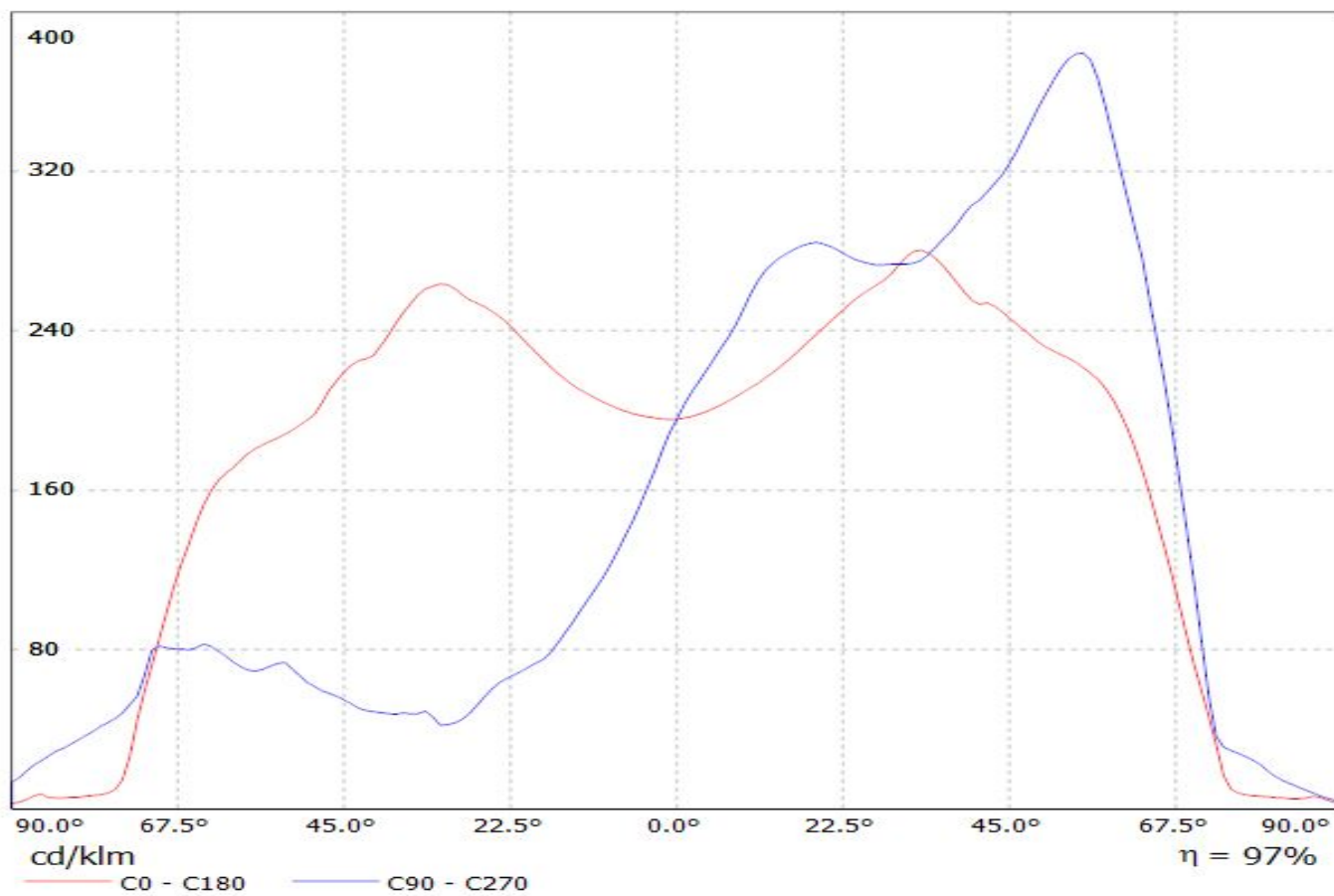

Ledil C13805_STRADA-2X2-T4_(TL1L4) / LDC (Linear)

Luminaire: Ledil C13805_STRADA-2X2-T4_(TL1L4)

Lamps: 1 x Toshiba_TL1L4_2x2_(TL1L4-DW0)_472.639lm@250mA_CCT=6500K_P=2.9W_I=0.25A

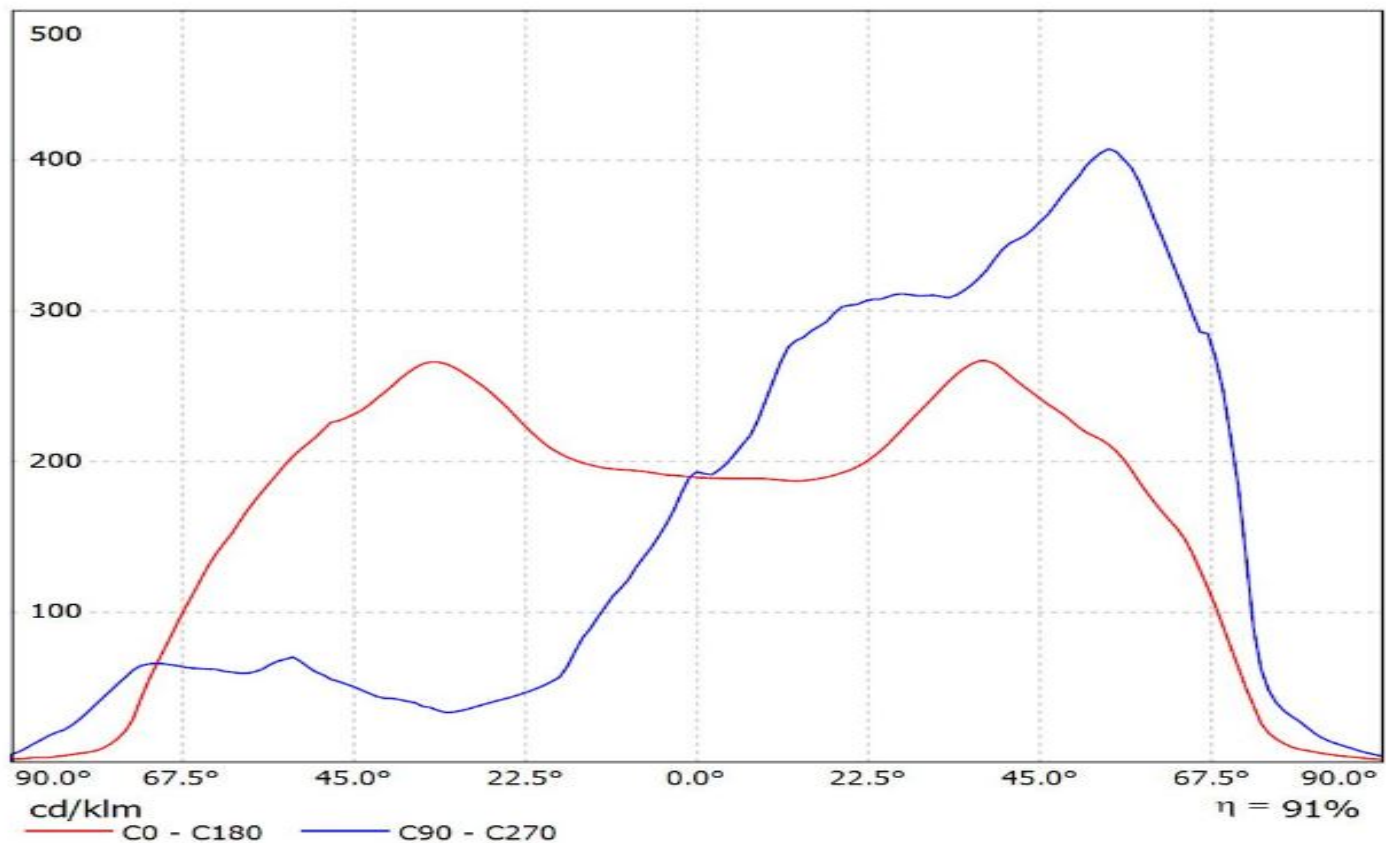

Luminaire: LEDiL Oy C13805_STRADA-2X2-T4_(Tridonic_Module_RLE_G1)
Lamps: 1 x Tridonic_Module_RLE_G1_4576.03lm@700mA_P=32.0681W_I=0.700A

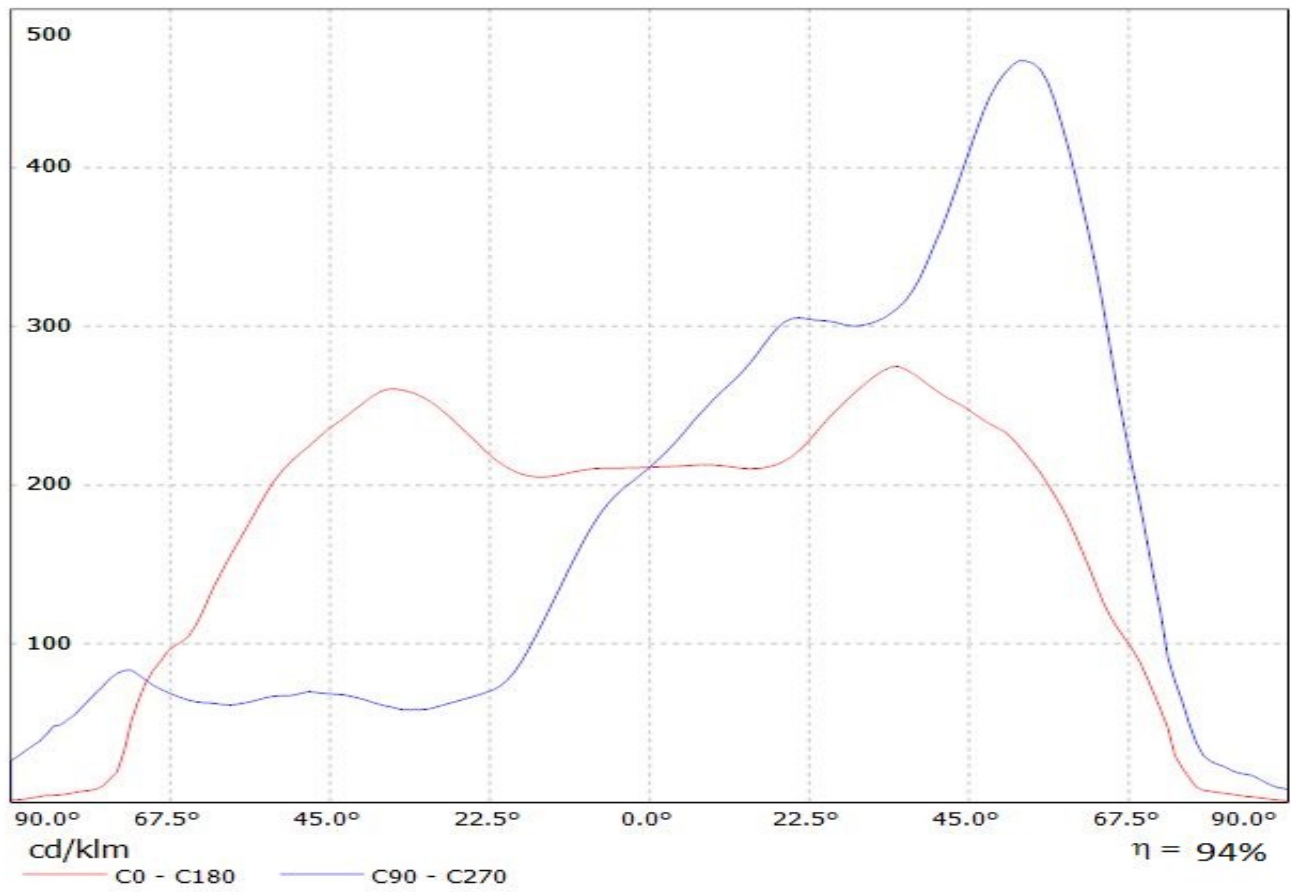

Luminaire: LEDiL Oy C13805_STRADA-2X2-T4_(Tridonic_Module_RLE_G1)
Lamps: 1 x Tridonic_Module_RLE_G1_4576.03lm@700mA_P=32.0681W_I=0.700A

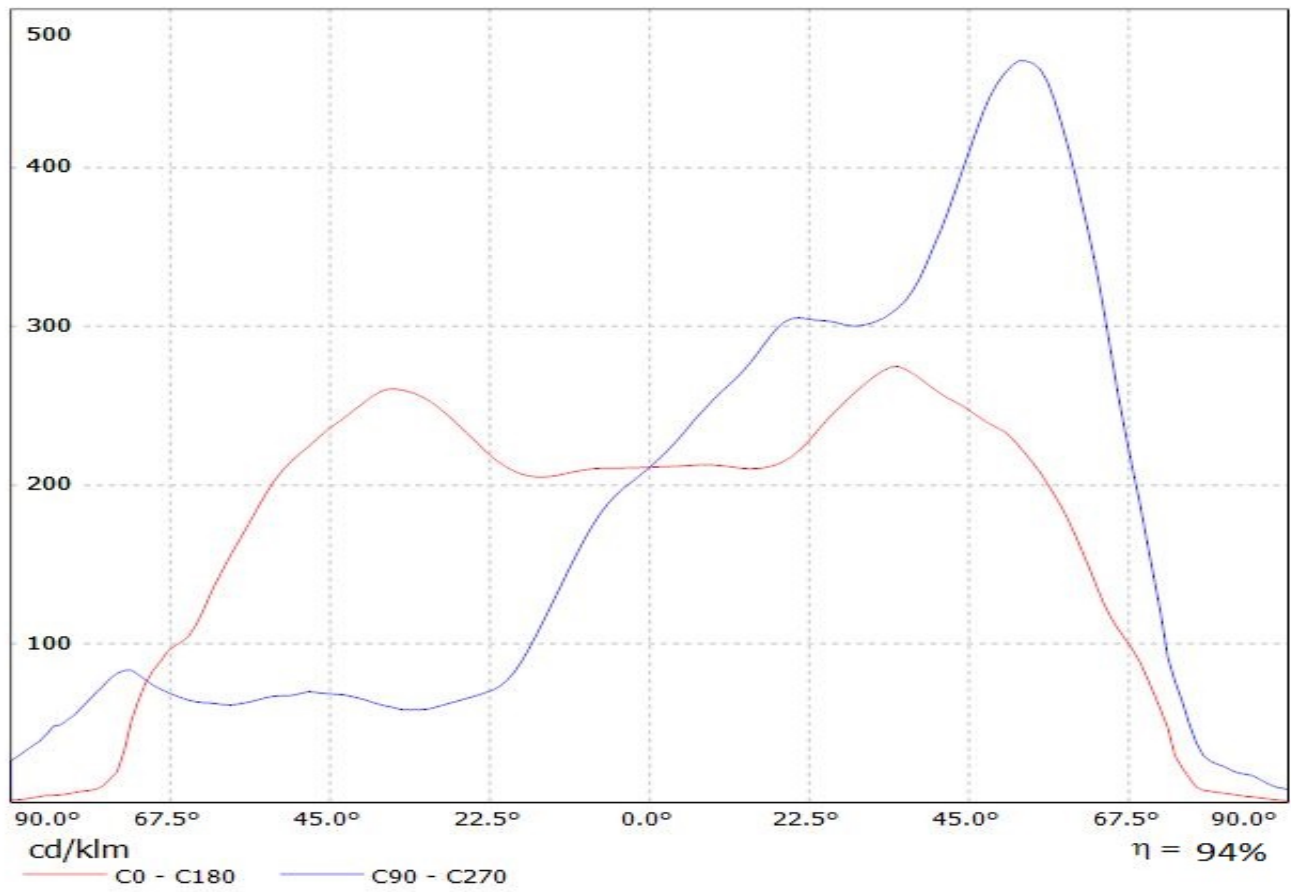

Luminaire: LEDiL Oy C13805_STRADA-2X2-T4_(Tridonic_Module_RLE_G1)
Lamps: 1 x Tridonic_Module_RLE_G1_2288lm@700mA_P=16W_I=0.700A

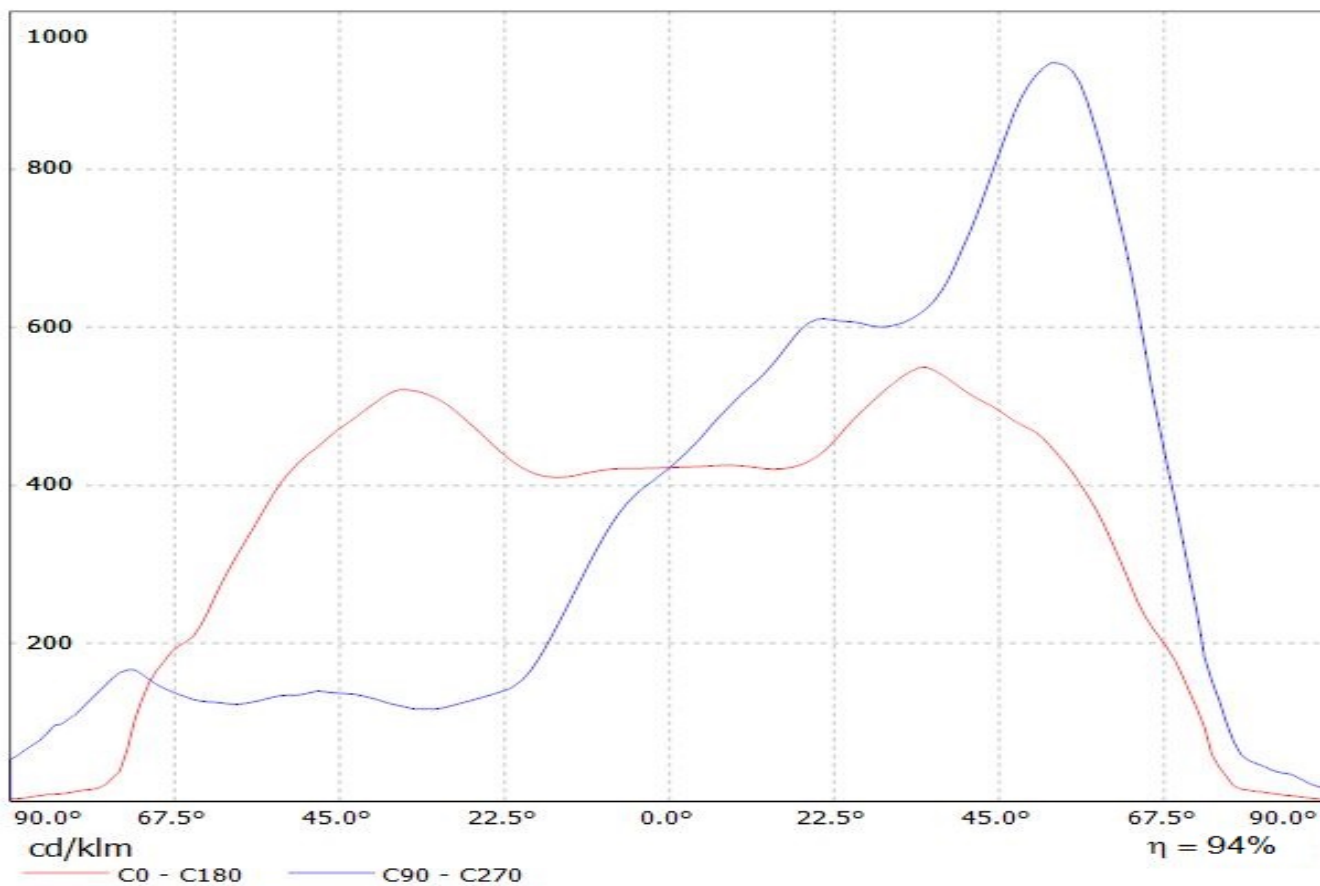

Luminaire: LEDiL Oy C13805_STRADA-2X2-T4_(Tridonic_Module_RLE_G1)
Lamps: 1 x Tridonic_Module_RLE_G1_2288lm@700mA_P=16W_I=0.700A

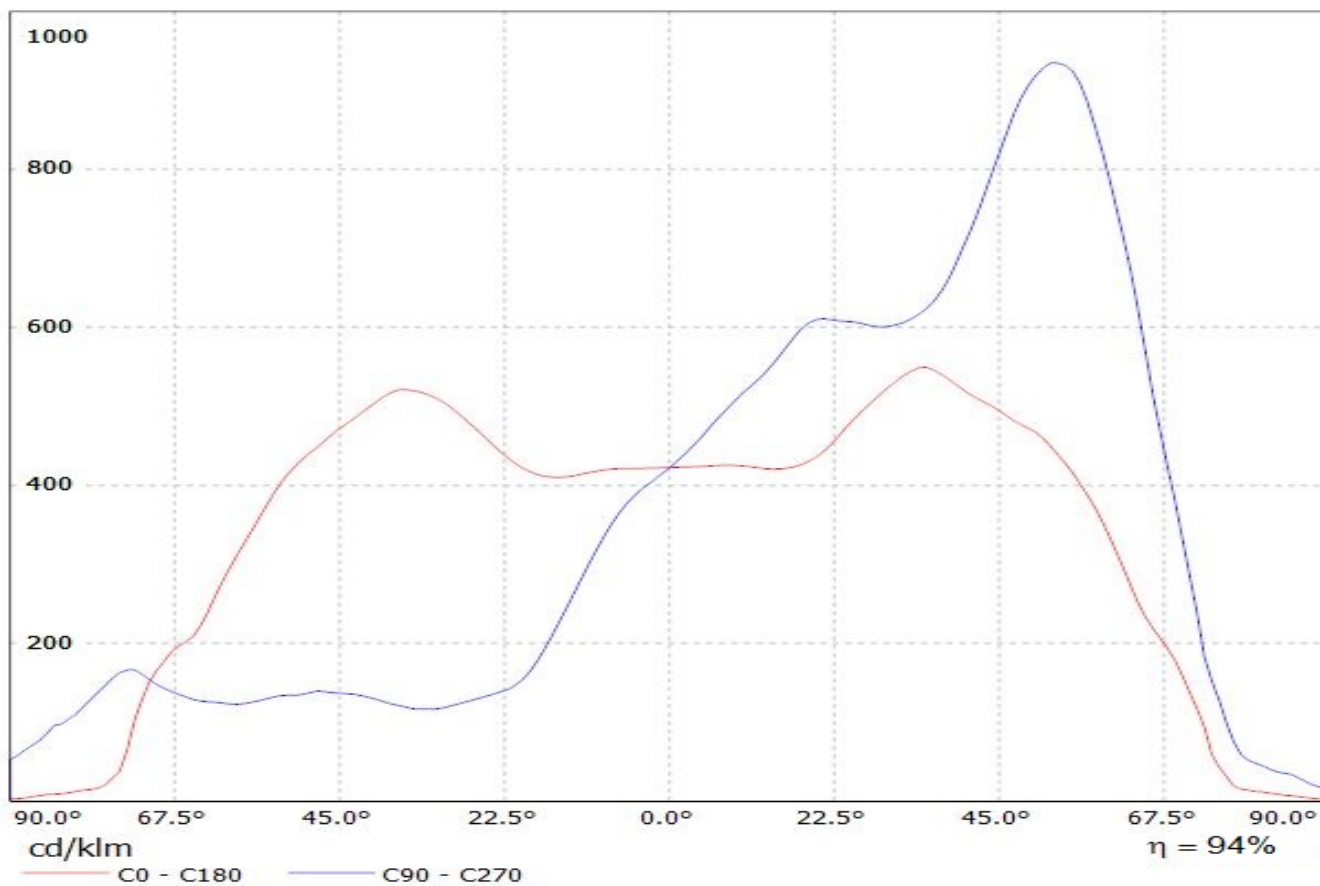

Luminaire: LEDiL Oy C13805_STRADA-2X-T4 (XM-L)_4 Eff.94.8%
Lamps: 1 x CREE_XM-L_2x2_354.749lm@250mA_P=2.82762W_I=249.9mA

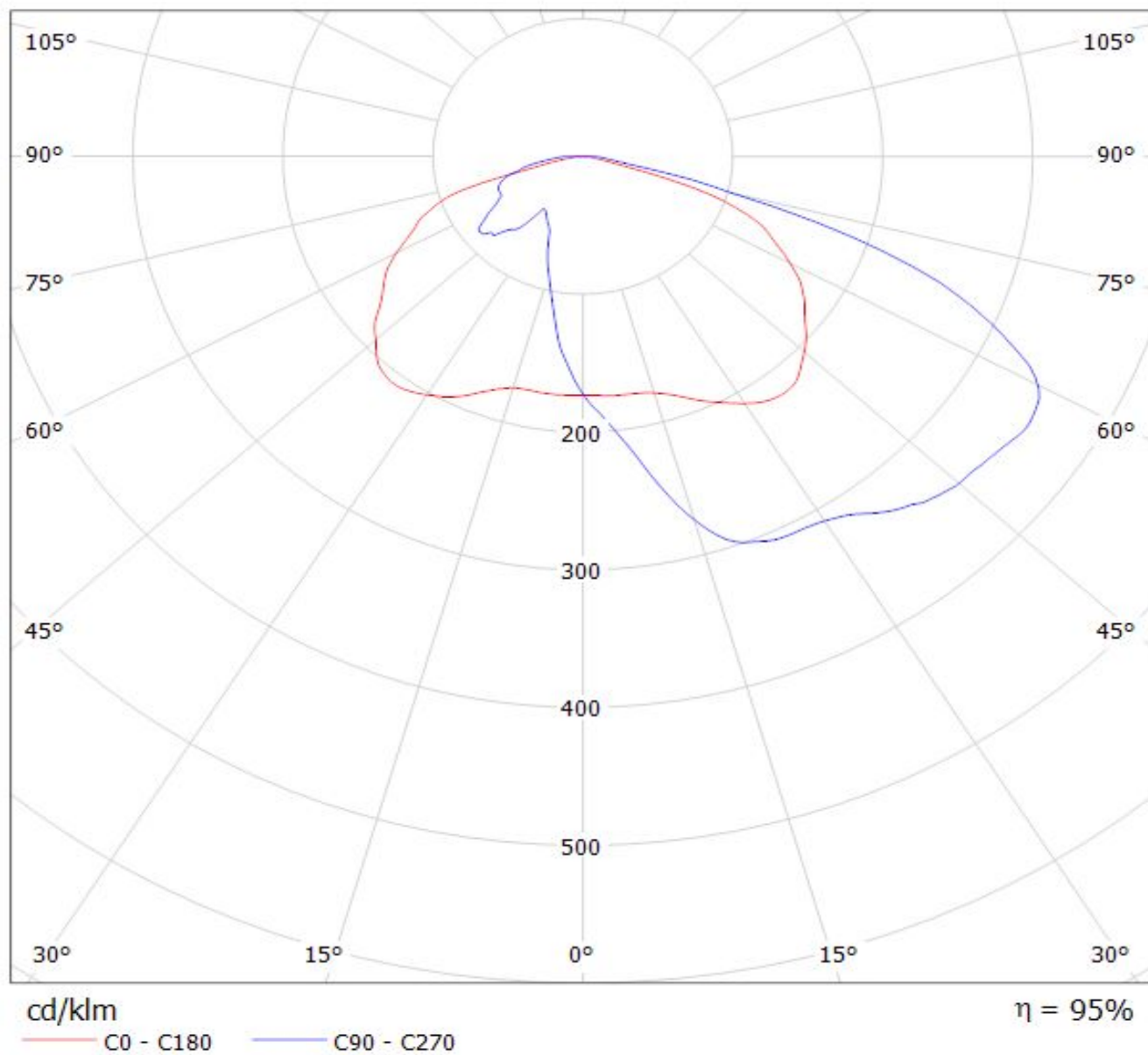

LEDiL Oy C13805_STRADA-2X2-T4_(XP-G) Eff.94.0% / LDC (Polar)

Luminaire: LEDiL Oy C13805_STRADA-2X2-T4_(XP-G) Eff.94.0%

Lamps: 1 x CREE_XP-G_2x2_254.292lm@250mA_P=2.89709W_I=249.9mA

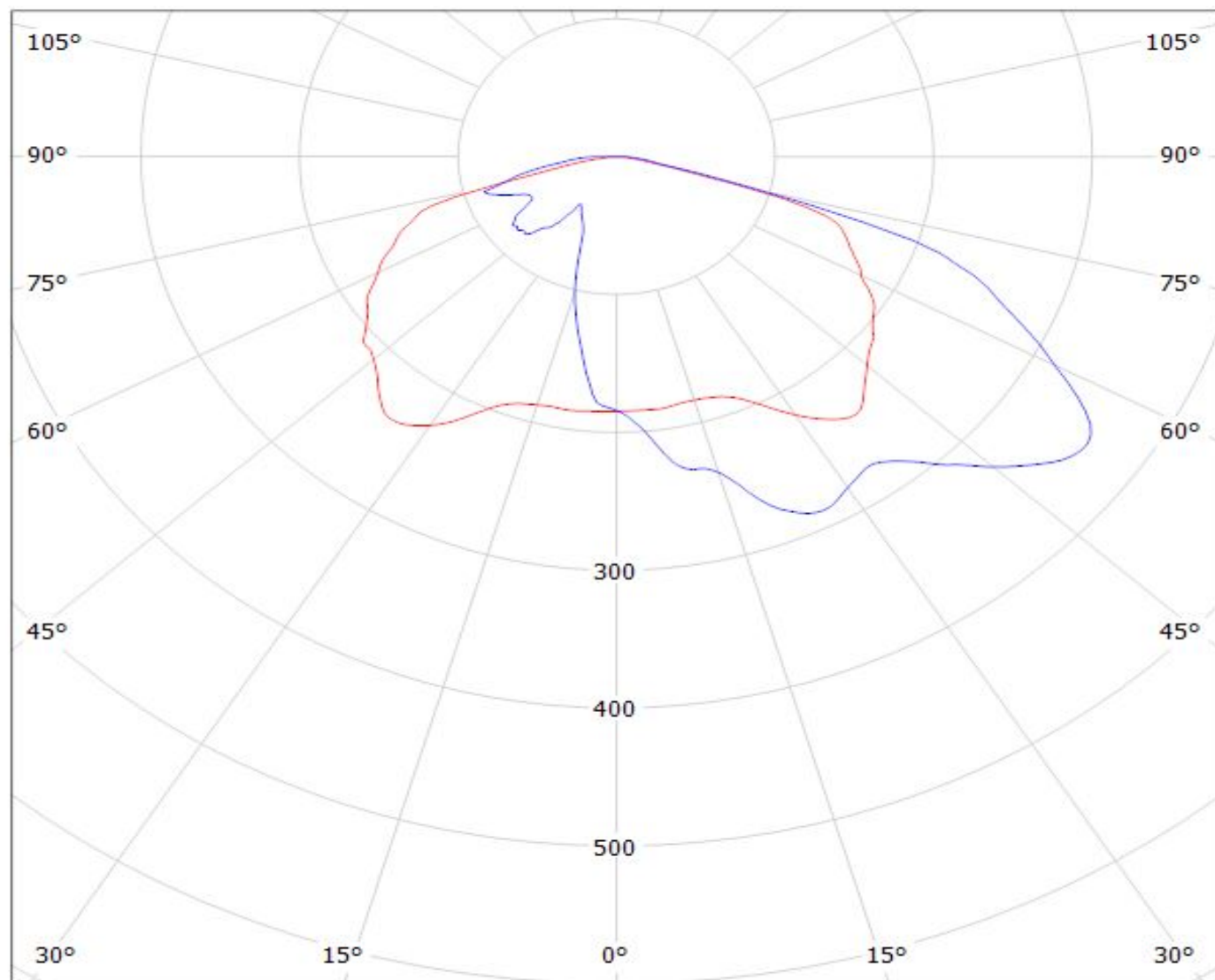

cd/klm

— C0 - C180

— C90 - C270

$\eta = 94\%$

LEDiL Oy C13805_STRADA-2X2-T4_(XT-E) Eff.94.0% / LDC (Polar)

Luminaire: LEDiL Oy C13805_STRADA-2X2-T4_(XT-E) Eff.94.0%

Lamps: 1 x CREE_XT-E_2x2_381.369lm@250mA_CCT=5717K_P=2.9868W_I=249.9mA

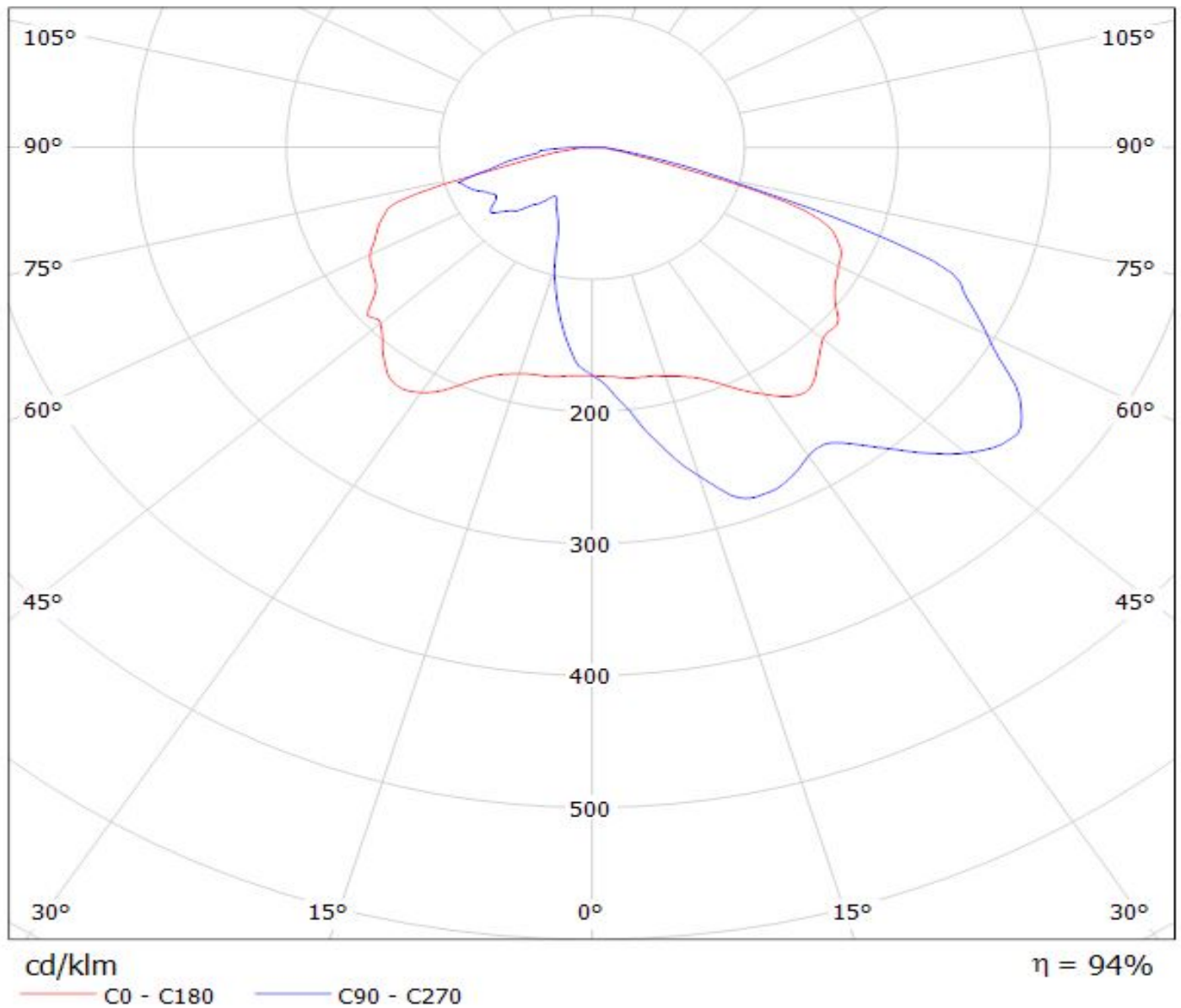

Luminaire: LEDiL Oy C13805_STRADA-2x2-T4_(XP-L)

Lamps: 1 x CREE_XP-L_2x2_(XPLAWT-0-1B0-V40-00-0001)_515lm@250mA_CCT=7600K_P=2.79963W_I=249.9mA

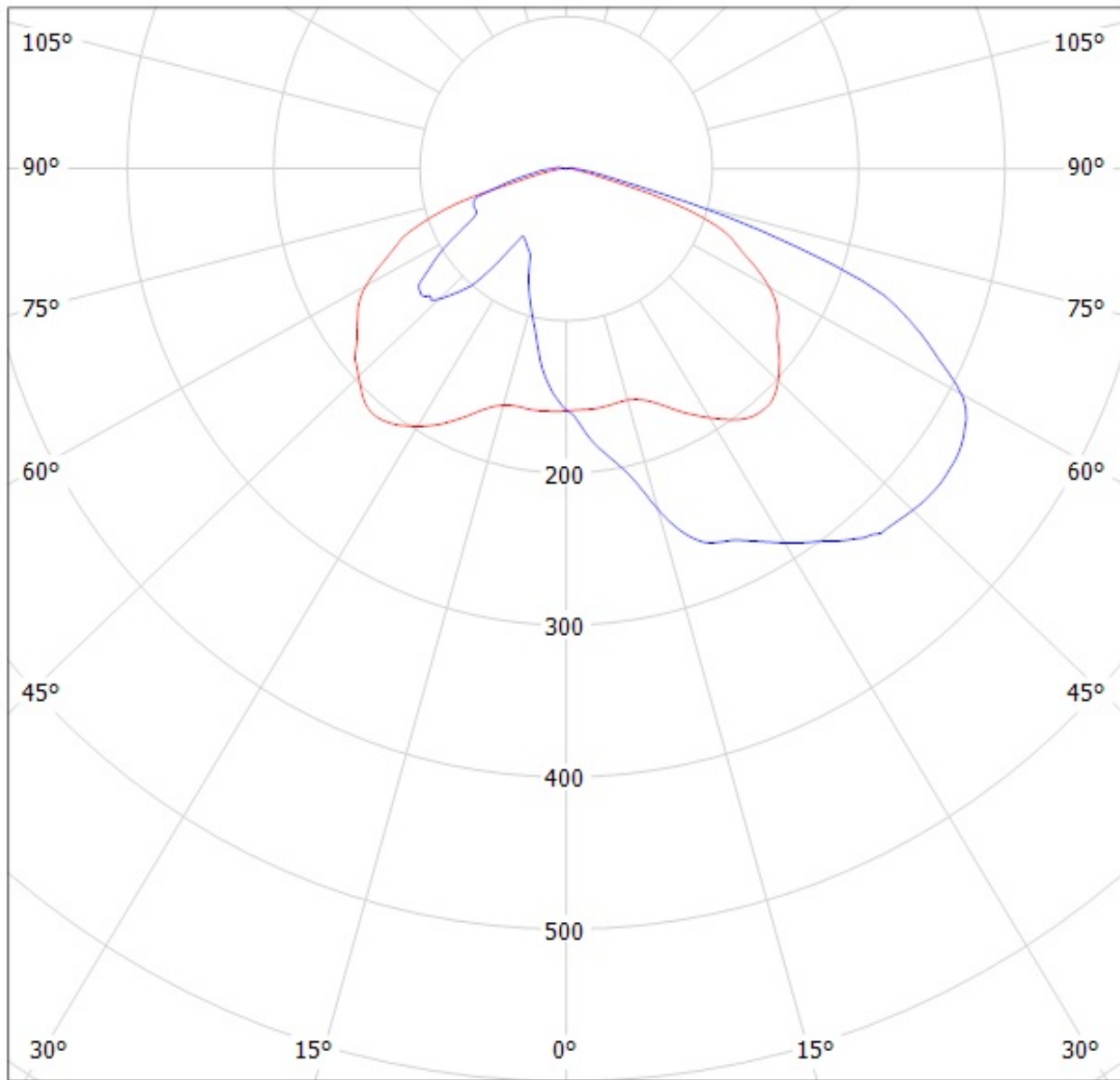

cd/klm

$\eta = 94\%$

— C0 - C180 — C90 - C270

Luminaire: LEDiL Oy C13805_STRADA-2X2-T4_(XP-L_HI)
Lamps: 1 x Cree_XP-L_HI_(2x2)_(XPLAWT-H-5A3-U60-013-0001)
_455.077lm@250mA_P=2.84011W_I=0.2499A

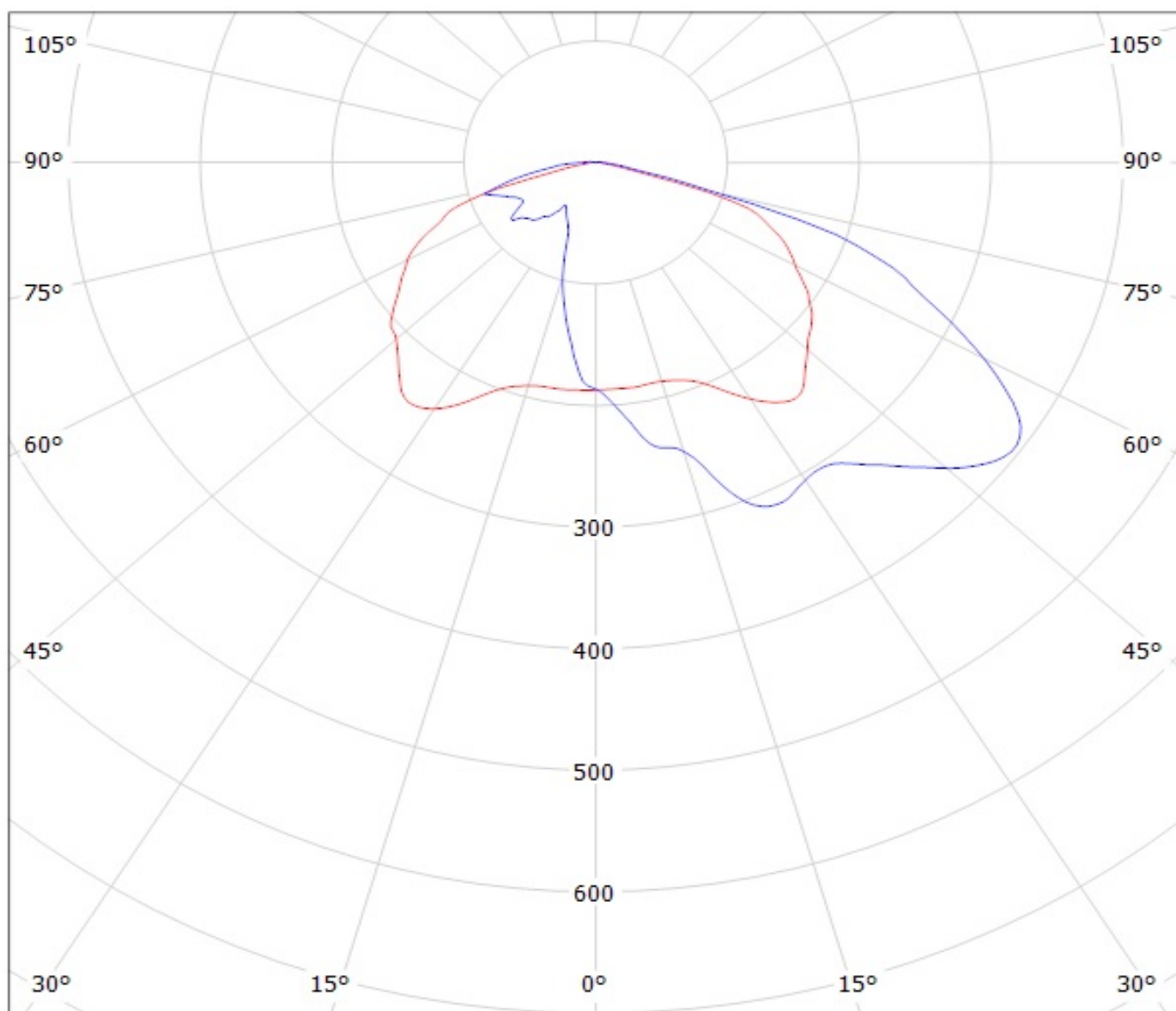

cd/klm

— C0 - C180 — C90 - C270

$\eta = 96\%$

Luminaire: LEDiL Oy C13805_STRADA-2X2-T4_(XP-G2)

Lamps: 1 x Cree_XP-G2_(XPGBWT-L1-000-00-G51)_409.462lm@250mA_P=2.94407_I=0.250A

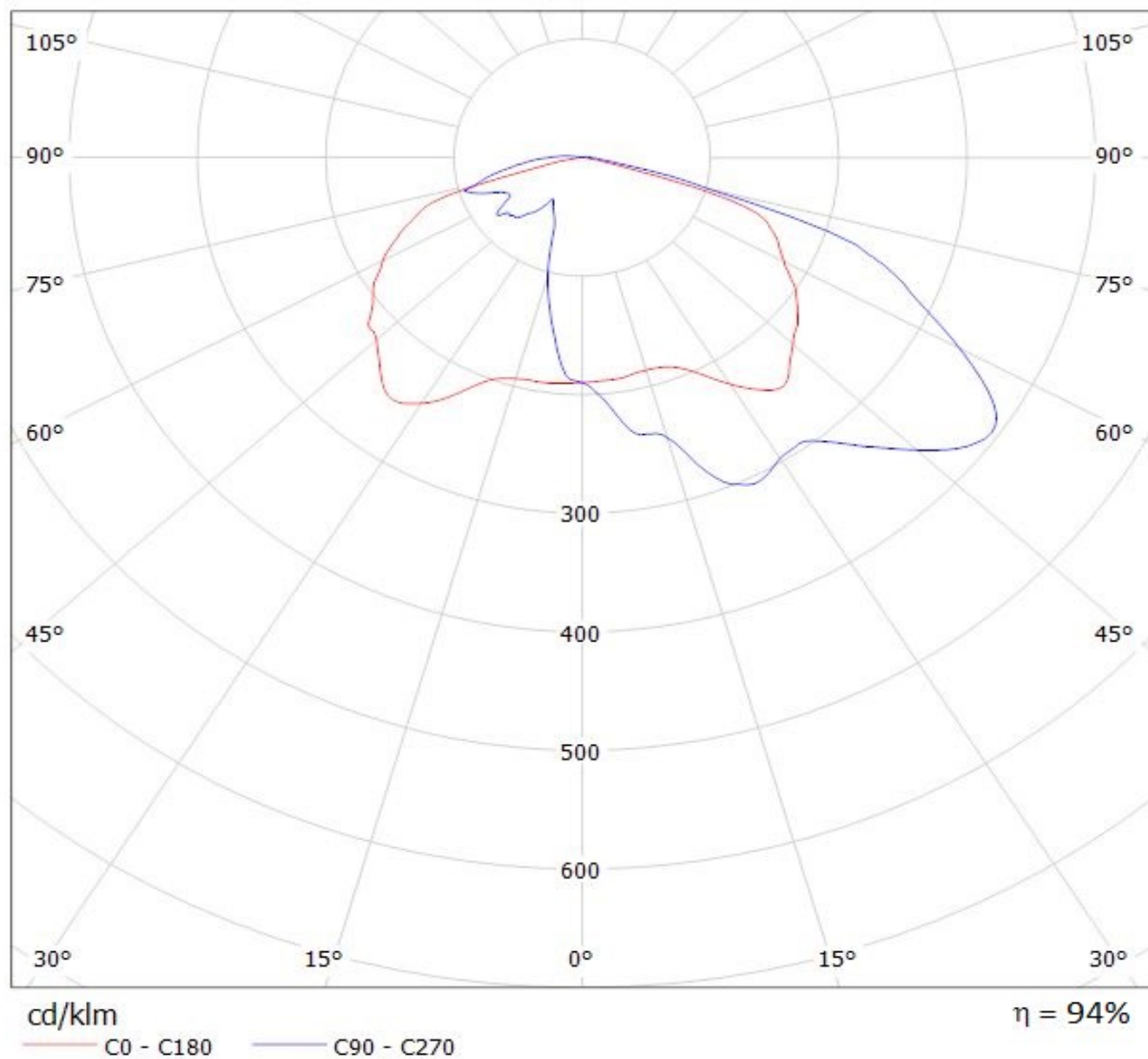

Luminaire: Ledil C13805_STRADA-2X2-T4_(XP-G3)

Lamps: 1 x Cree_XP-G3_2x2_(XPGDWT-B1-3C0-S4-0-01)_516.212lm@250mA_P=2.78875W_I=0.250A

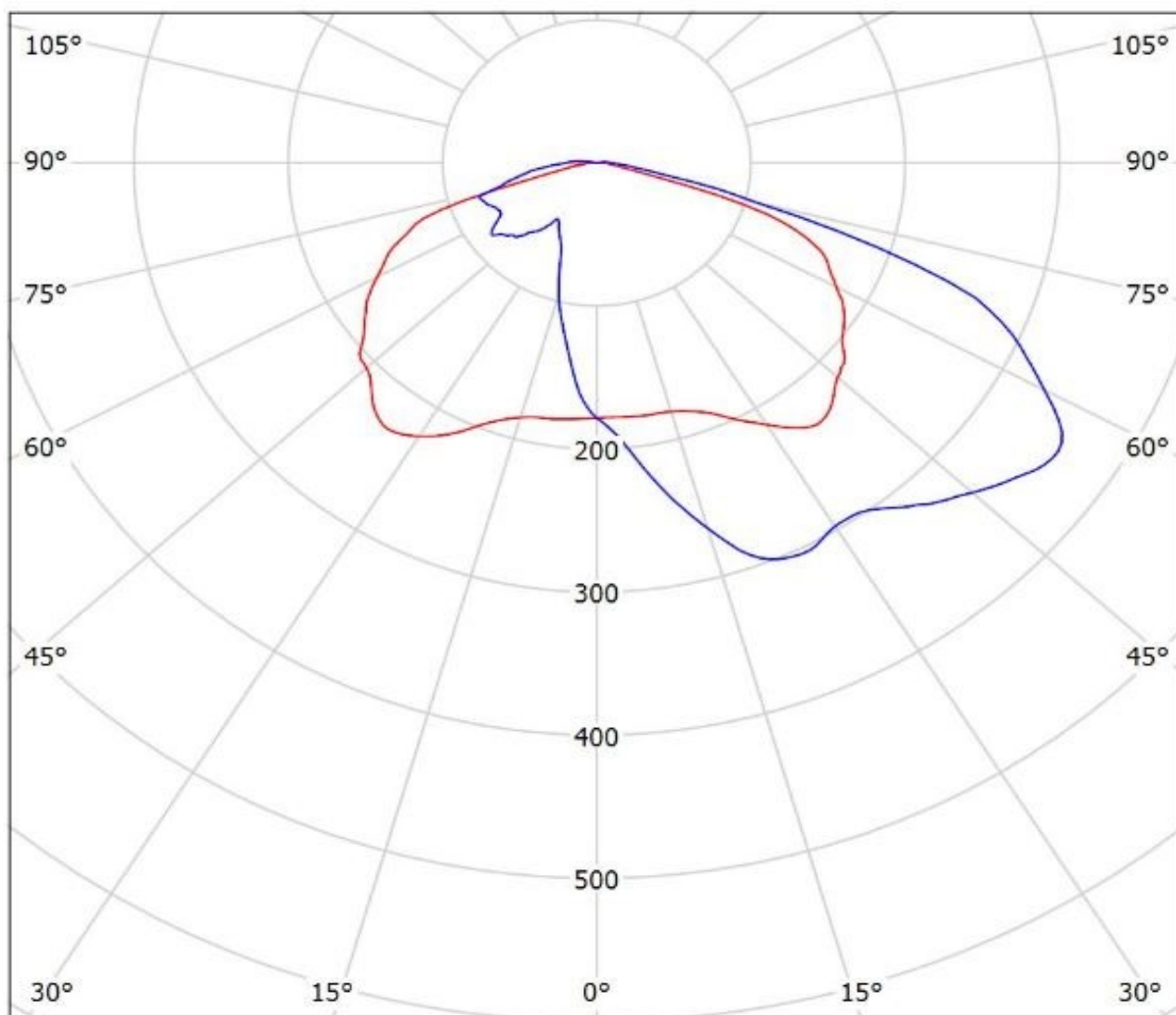

cd/klm

— C0 - C180 — C90 - C270

$\eta = 94\%$

Luminaire: Ledil C13805_STRADA-2X2-T4_(XP-L2)

Lamps: 1 x Cree_XP-L2_2x2_(XPLBWT-00-0000-000BV50E3)550.93lm@250mA_P=2.7815W_I=0.25A

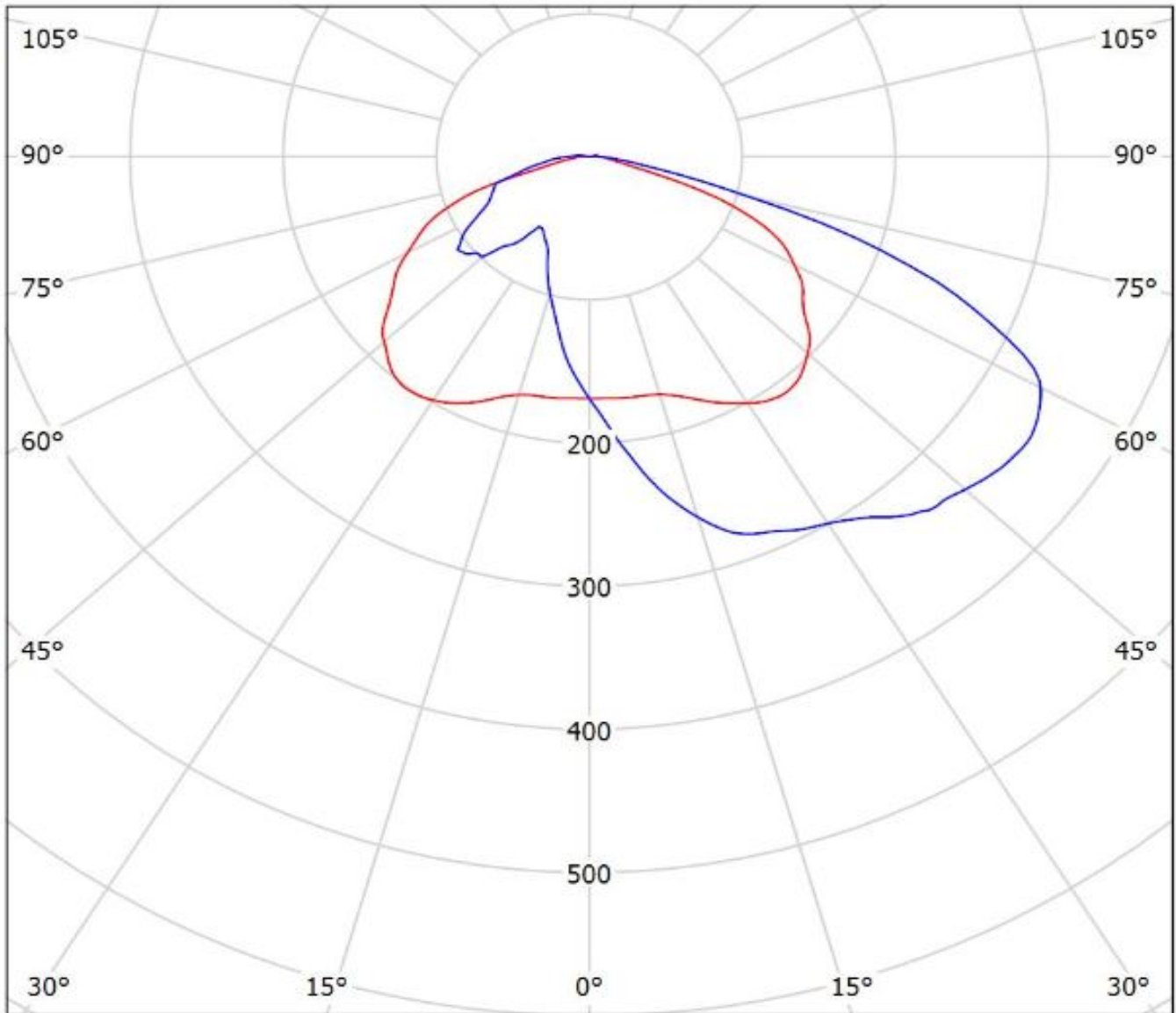

cd/klm

— C0 - C180 — C90 - C270

$\eta = 97\%$

Luminaire: Ledil C13805_STRADA-2X2-T4_(H35C1)
Lamps: 1 x LG_H35C1_2x2_477.216lm@250mA_P=2.87475W_I=0.250A

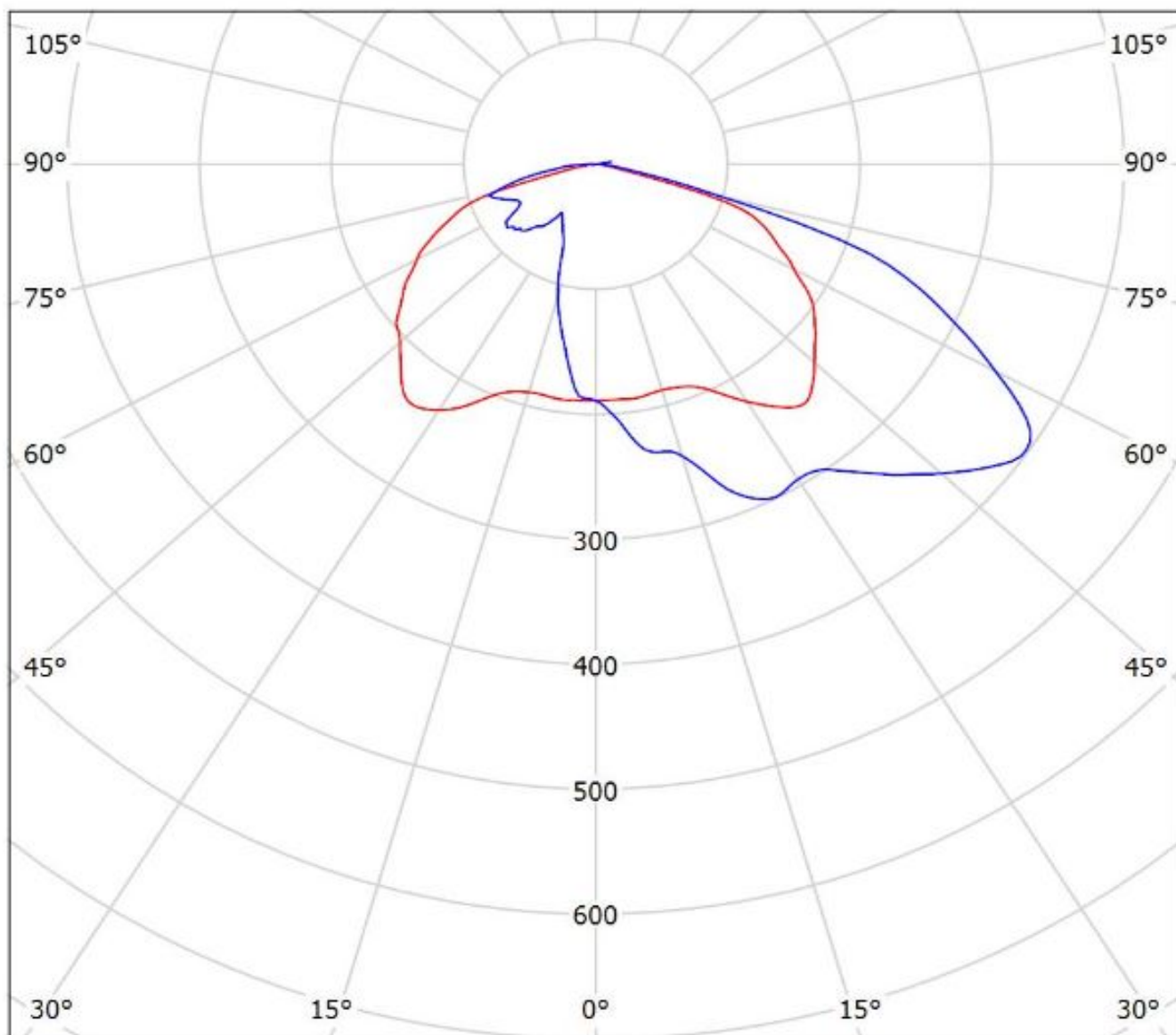

cd/klm
— C0 - C180 — C90 - C270

$\eta = 96\%$

Luminaire: LEDiL Oy C13805_STRADA-2X2-T4_(LUXEON_T) Eff. 95%

Lamps: 1 x LUXEON_T_2x2_(LXH8-FW30-3)_293lm@250mA_CCT=3173K_P=2.79801W_I=249.8mA

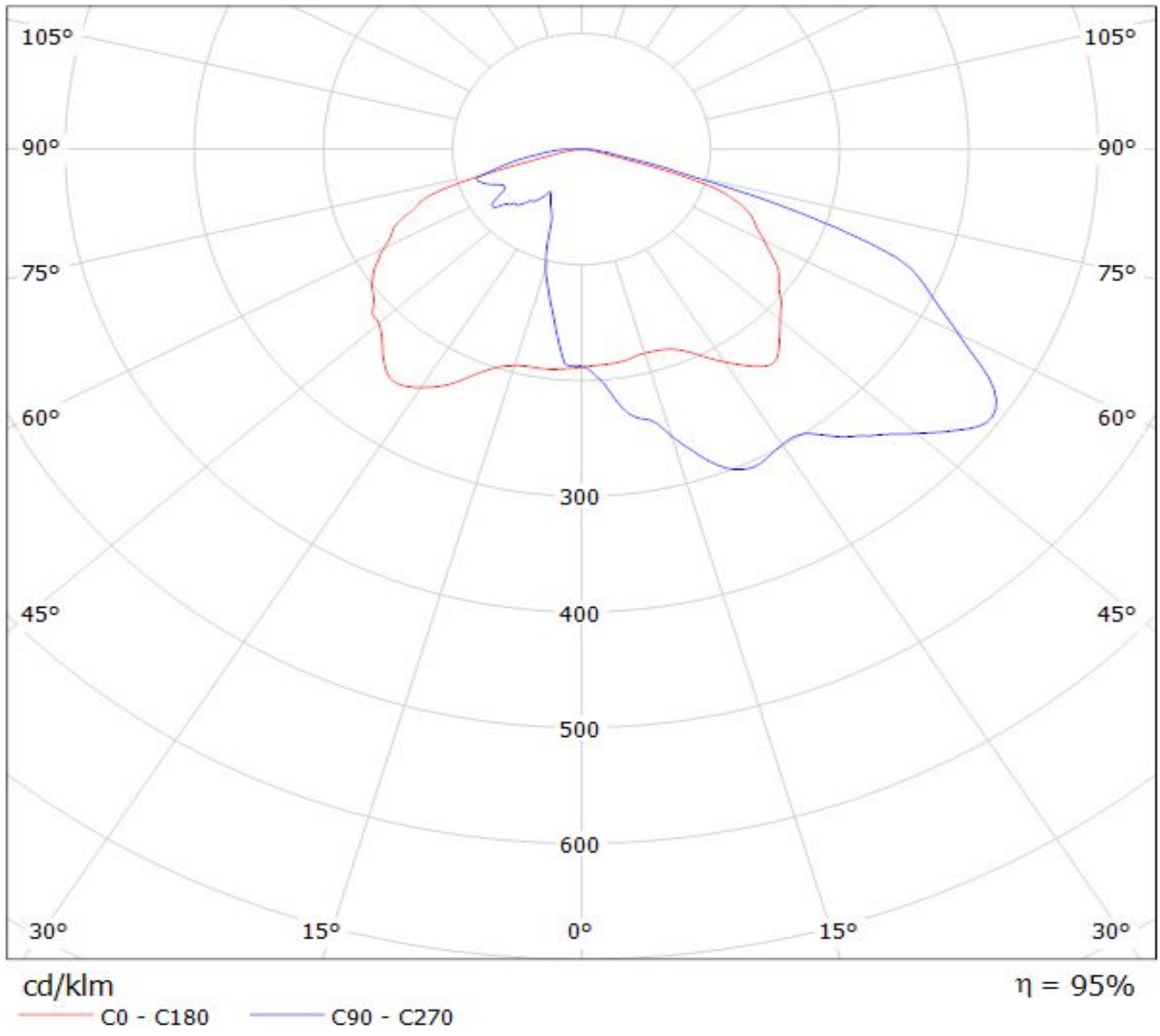

Luminaire: LEDiL Oy C13805_STRADA-2x2-T4_(LUXEON_Q)

Lamps: 1 x LUXEON_Q_2x2_(LHQ-3080)_299.038lm@250mA_P=2.8742W_I=249.8mA

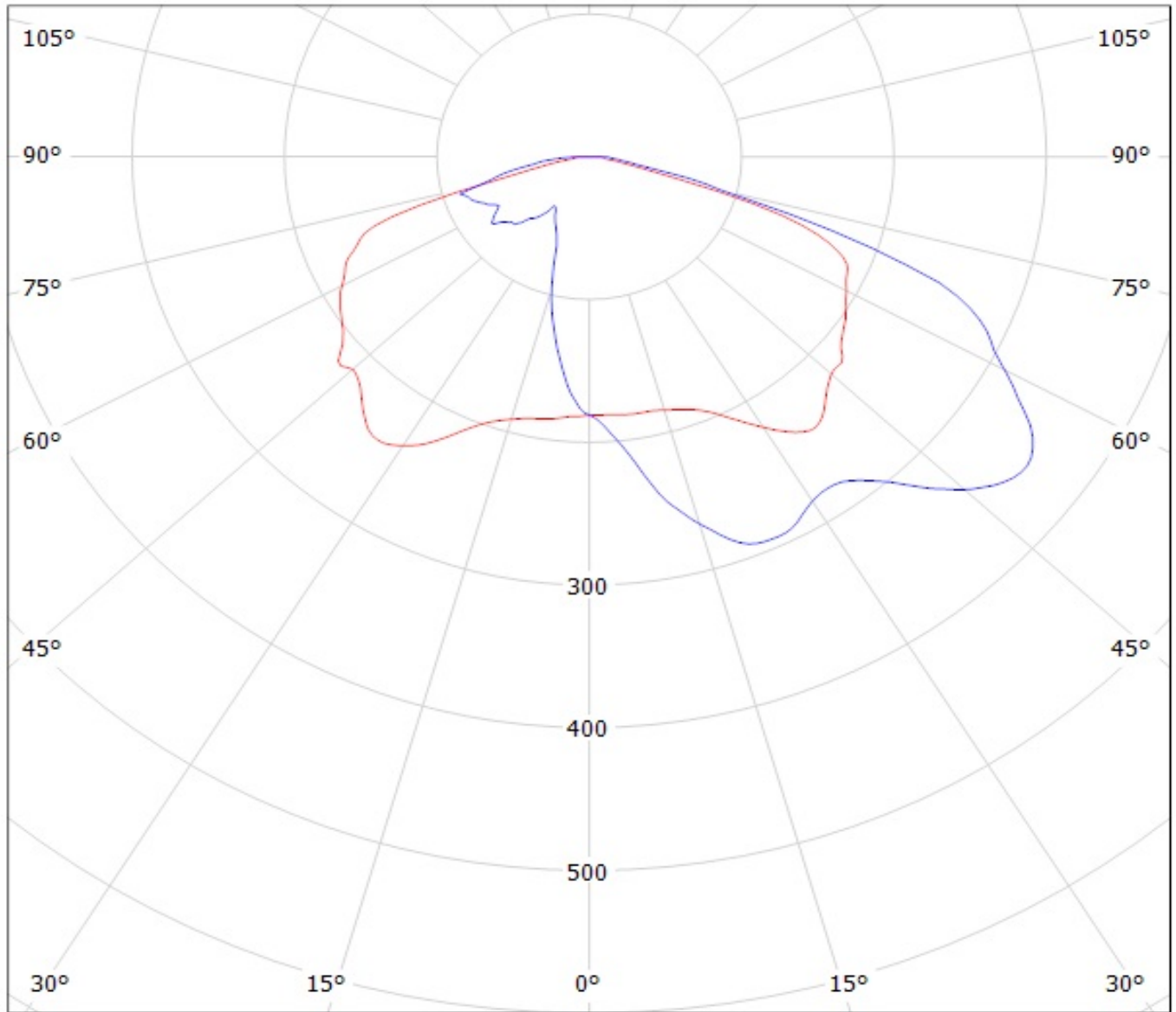

cd/klm

— C0 - C180

— C90 - C270

Luminaire: Ledil C13805_STRADA-2X2-T4_(Luxeon_MZ)

Lamps: 1 x Philips_Lumileds_Luxeon_MZ_(LMZ7-QW57)_(2x2)_427.268lm@250mA_P=2.734W_I=0.2500A

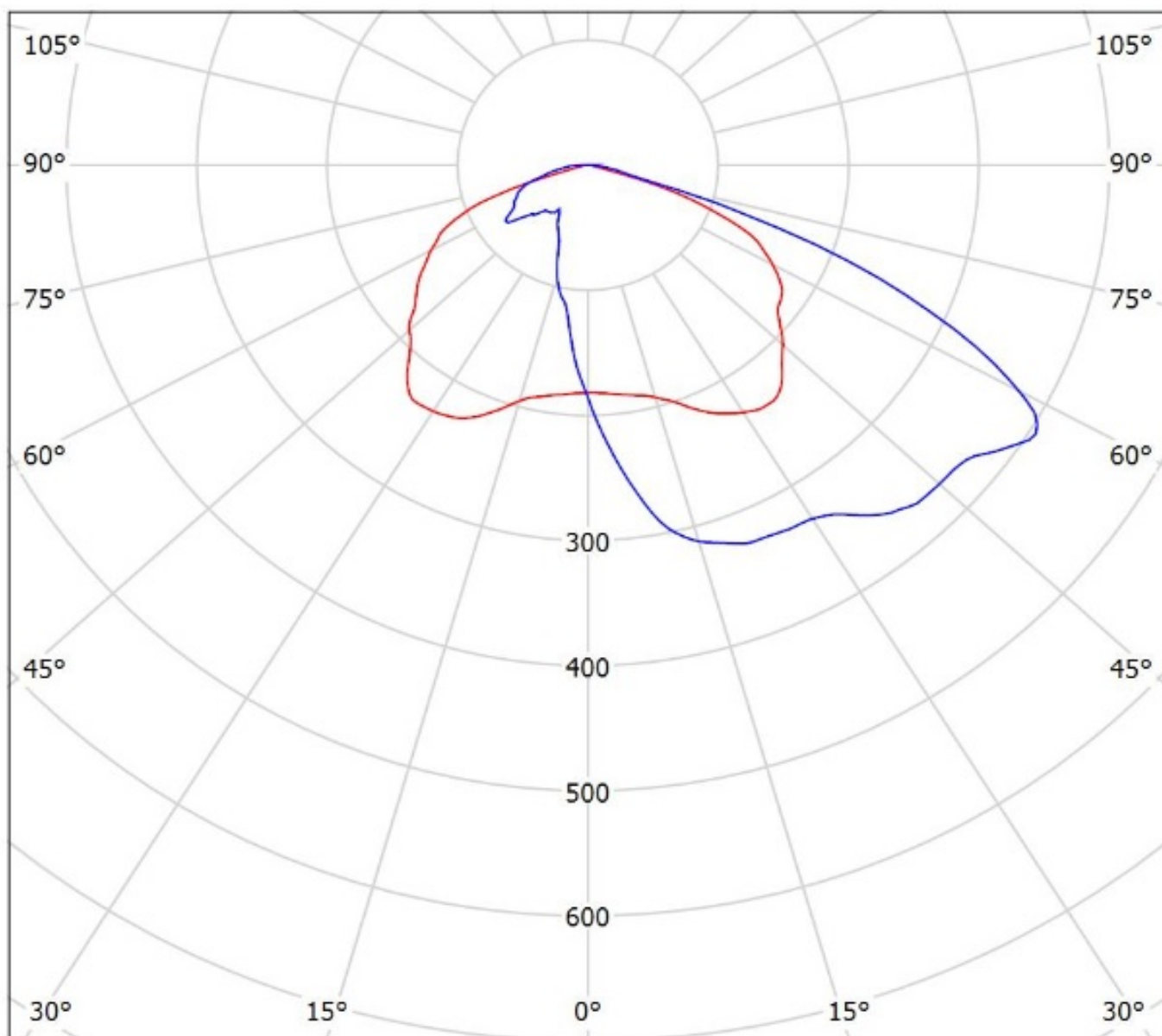

cd/klm

— C0 - C180 — C90 - C270

$\eta = 97\%$

Luminaire: LEDiL Oy C13805_STRADA-2X2-T4_(Luxeon_TX)
Lamps: 1 x Luxeon_TX_2x2_321.384lm@250mA_P=2.79488W_I=249.9mA

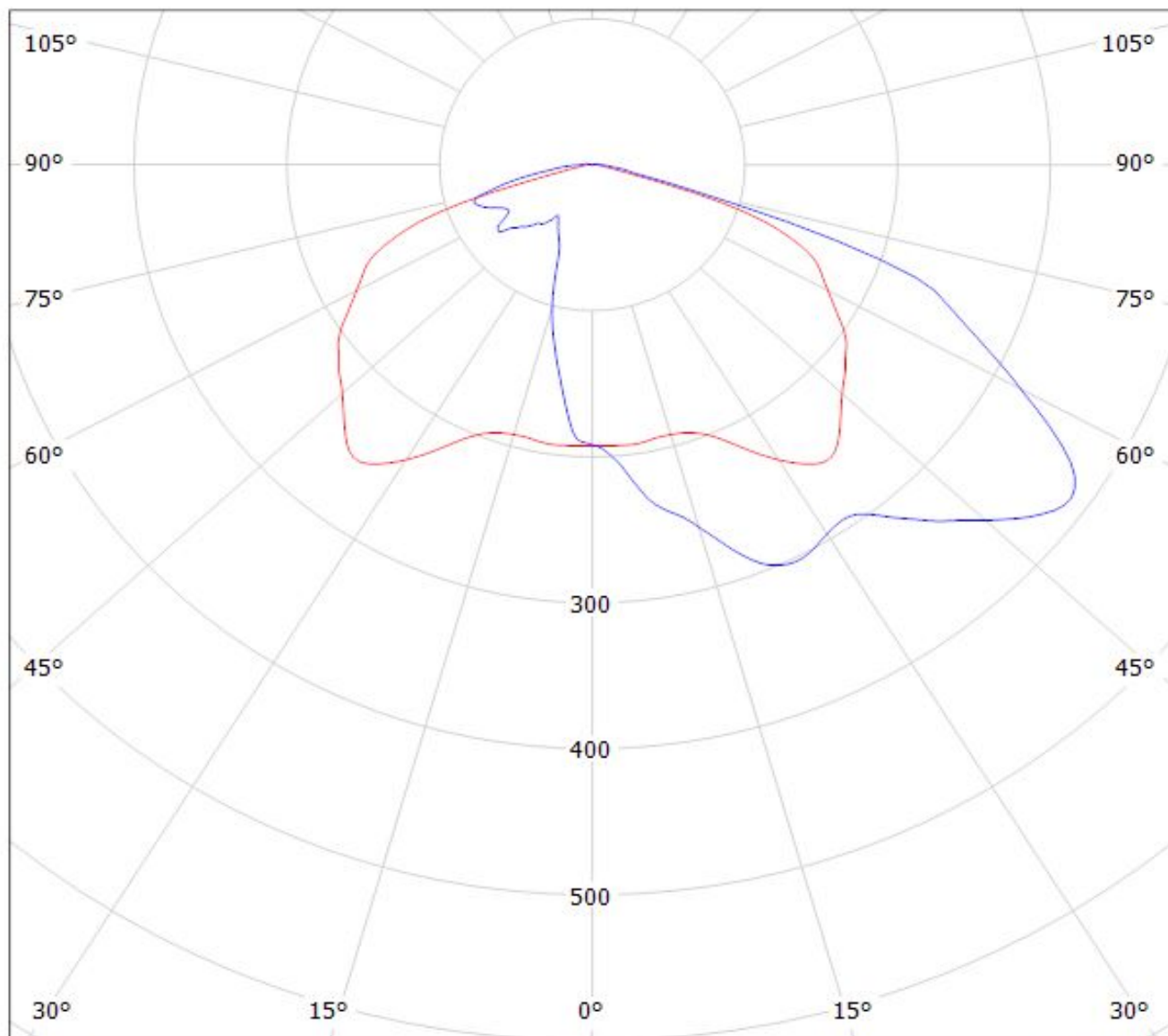

cd/klm

$\eta = 94\%$

— C0 - C180 — C90 - C270

Luminaire: LEDiL Oy C13805_STRADA-2X2-T4_(Luxeon_V)

Lamps: 1 x Lumileds_Luxeon_V_488.501lm@250mA_CCT=4000K_P=2.75155W_I=0.250A

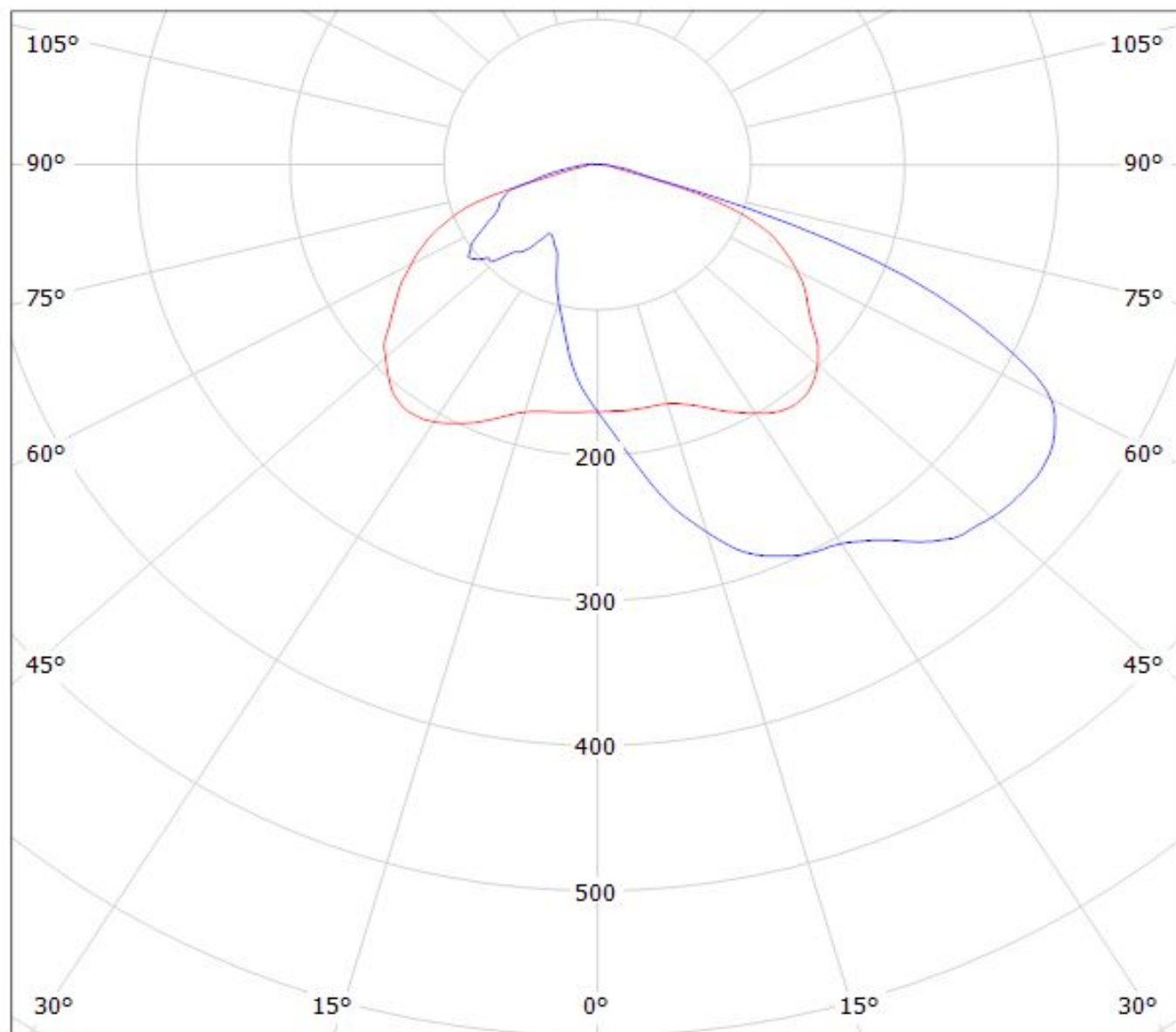

cd/klm

— C0 - C180

— C90 - C270

$\eta = 96\%$

Luminaire: LEDiL Oy C13805_STRADA-2X2-T4_(NVSW319AE)
Lamps: 1 x Nichia_NVSW319AE_499.093lm@250mA_P=2.79052W_I=0.25A

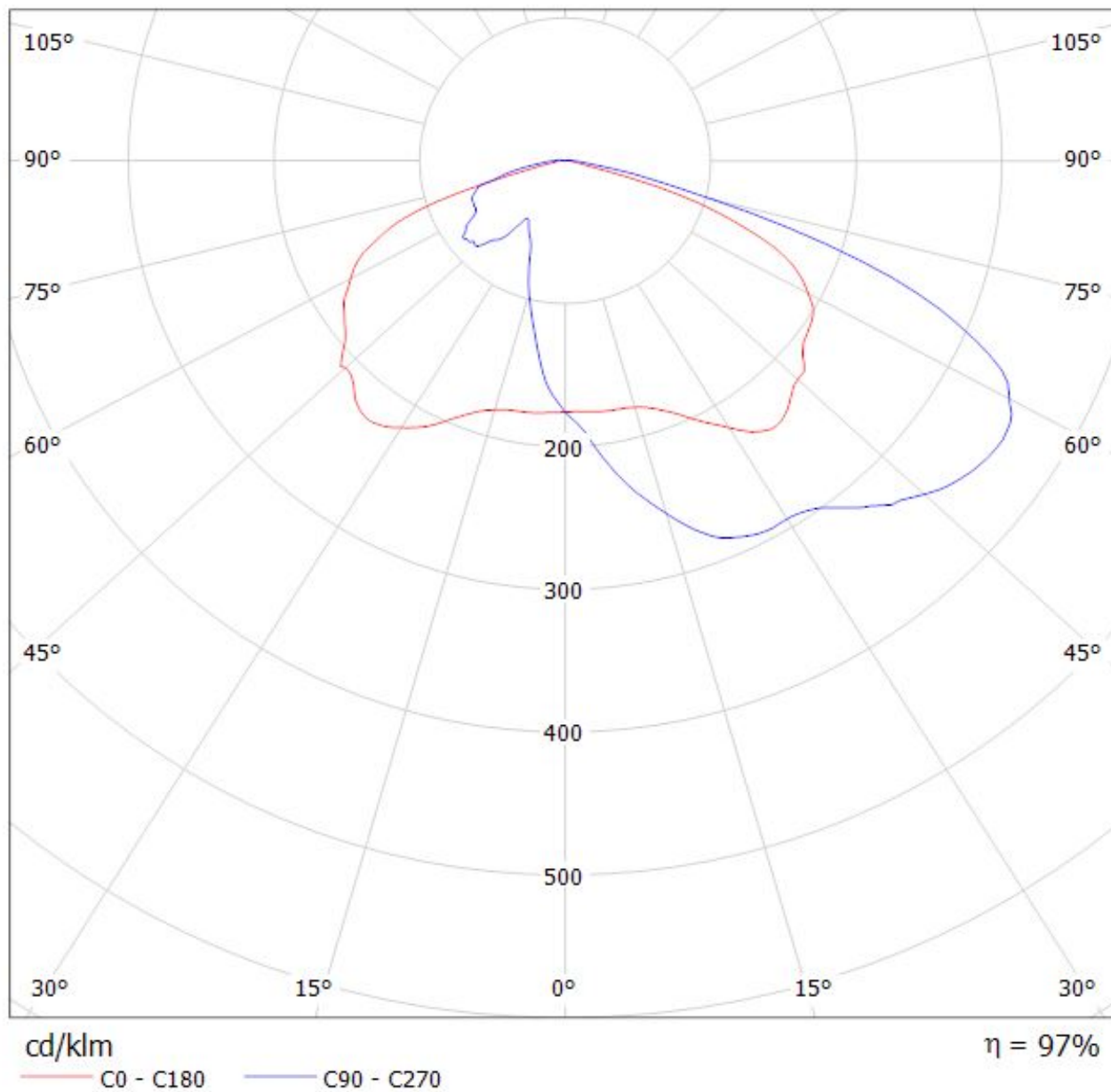

Luminaire: LEDiL Oy C13805_STRADA-2X2-T4_(Oslon_Square_PC_2x2)
Lamps: 1 x Osram_Oslon_Square_PC_2x2_(GWCSSRM1.PC)
_411.322lm@250mA_P=2.85186W_I=0.2499A

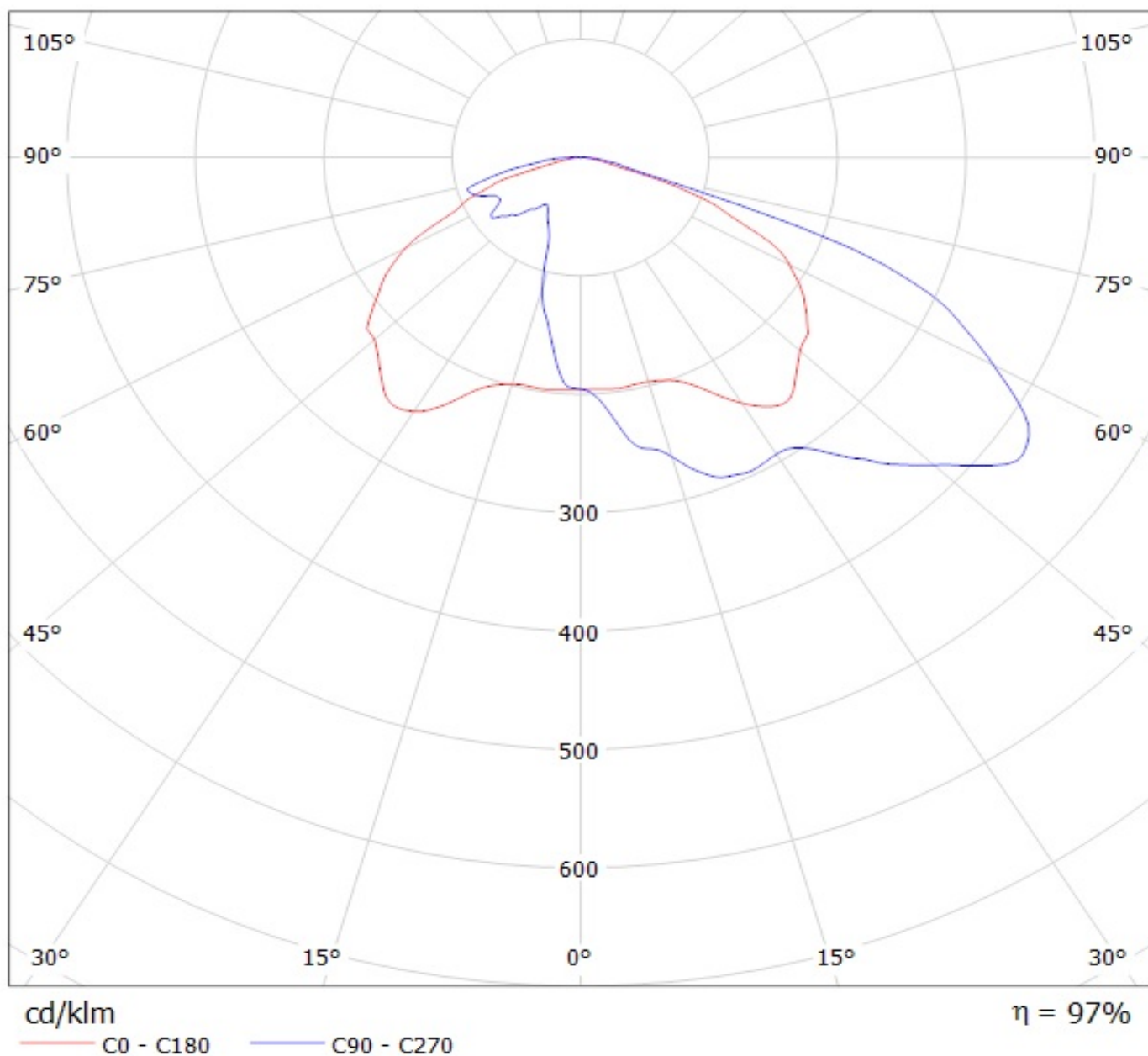

Luminaire: Ledil Oy C13805STRADA-2X2-T4_(Duris_S8_Gen2)_SIMULATED
Lamps: 1 x OSRAM_DURIS S8 GEN2 5050 package

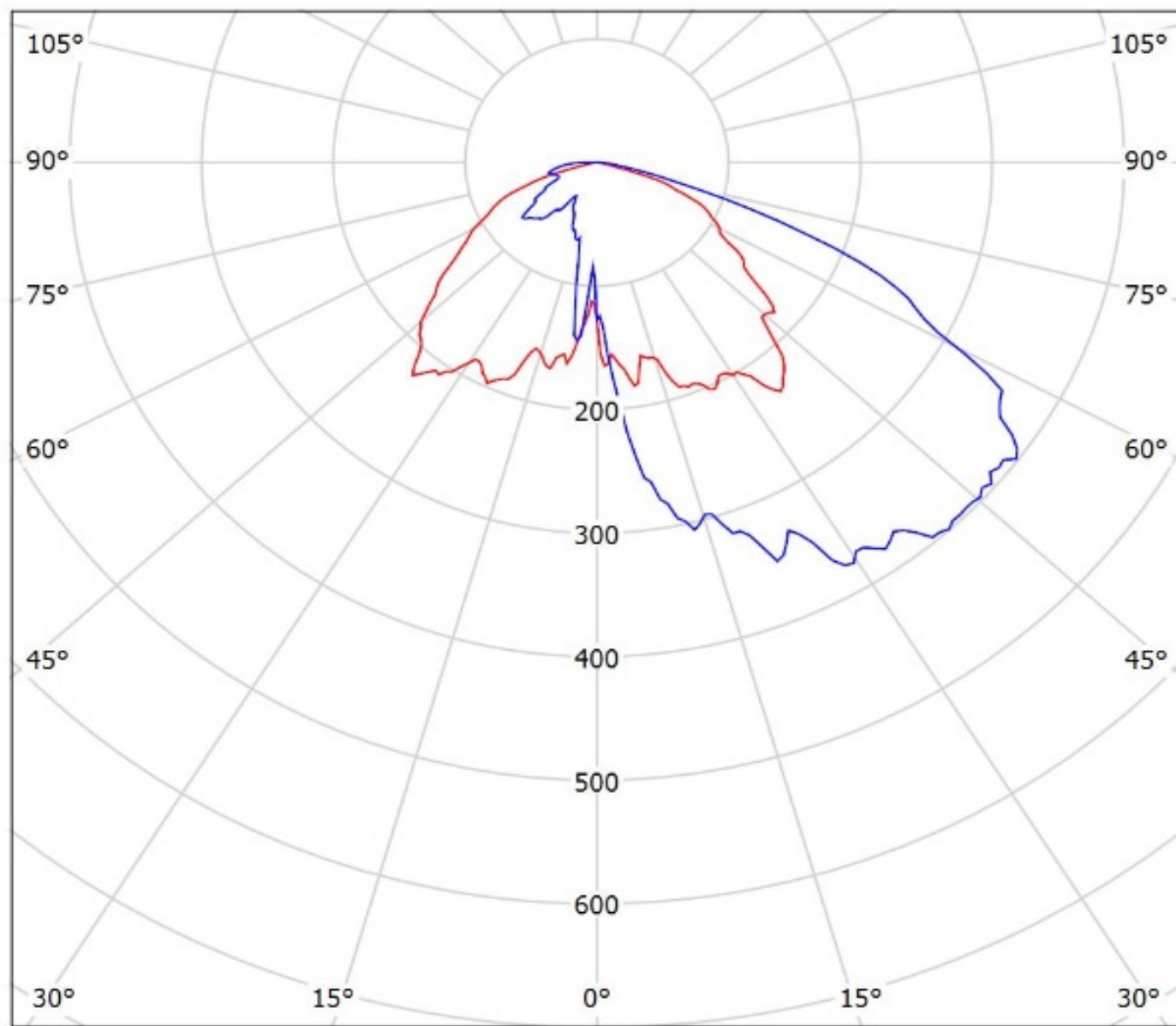

cd/klm
— C0 - C180 — C90 - C270

$\eta = 93\%$

Luminaire: Ledil Oy C13805_STRADA-2X2-T4_(Duris_P8)_SIMULATED
Lamps: 1 x Osram Duris P8

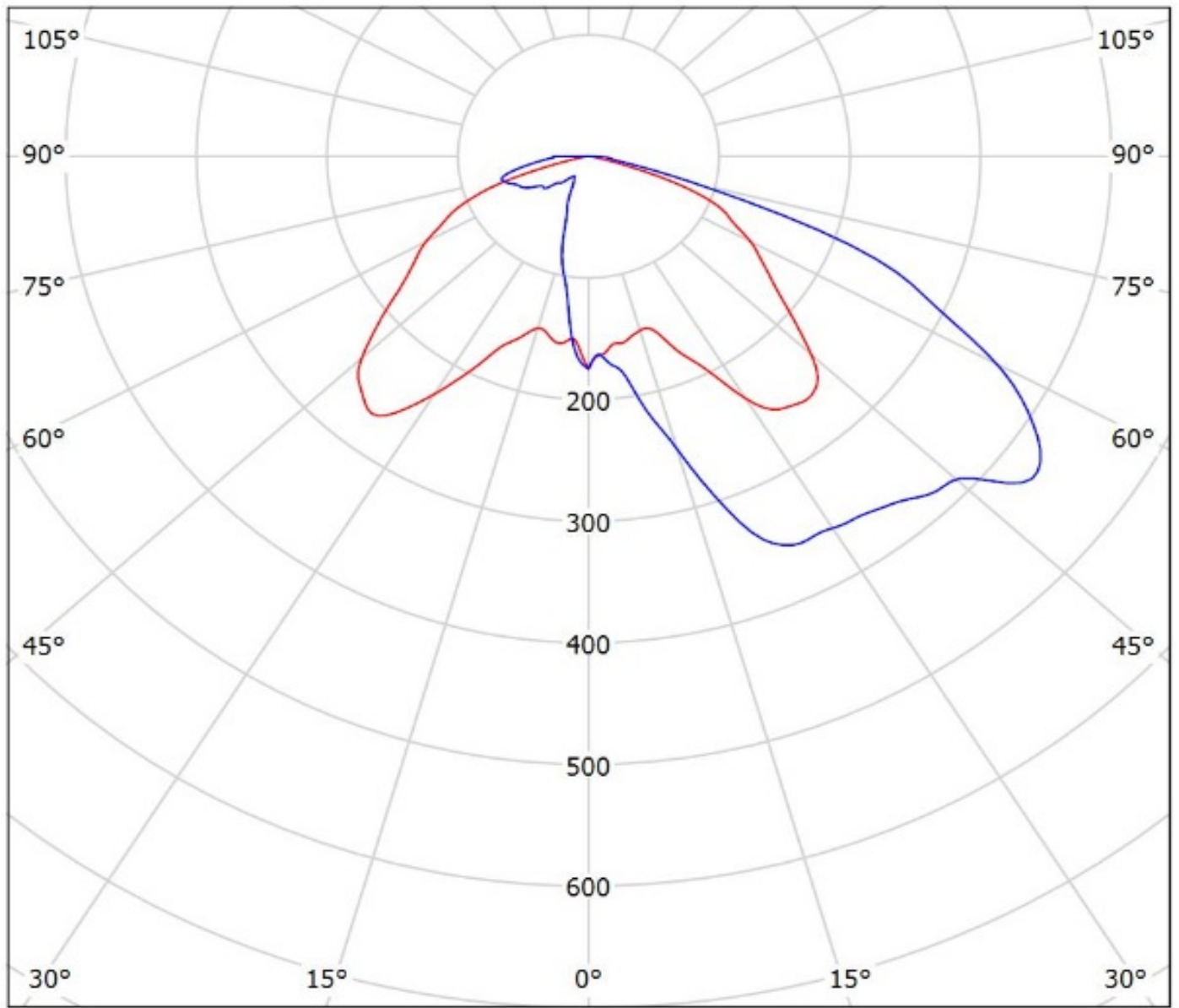

cd/klm

— C0 - C180 — C90 - C270

$\eta = 93\%$

Luminaire: Ledil Oy C13805_STRADA-2X2-T4_OSRAM_DURIS_P9_SIMULATED
Lamps: 1 x OSRAM DURIS P9

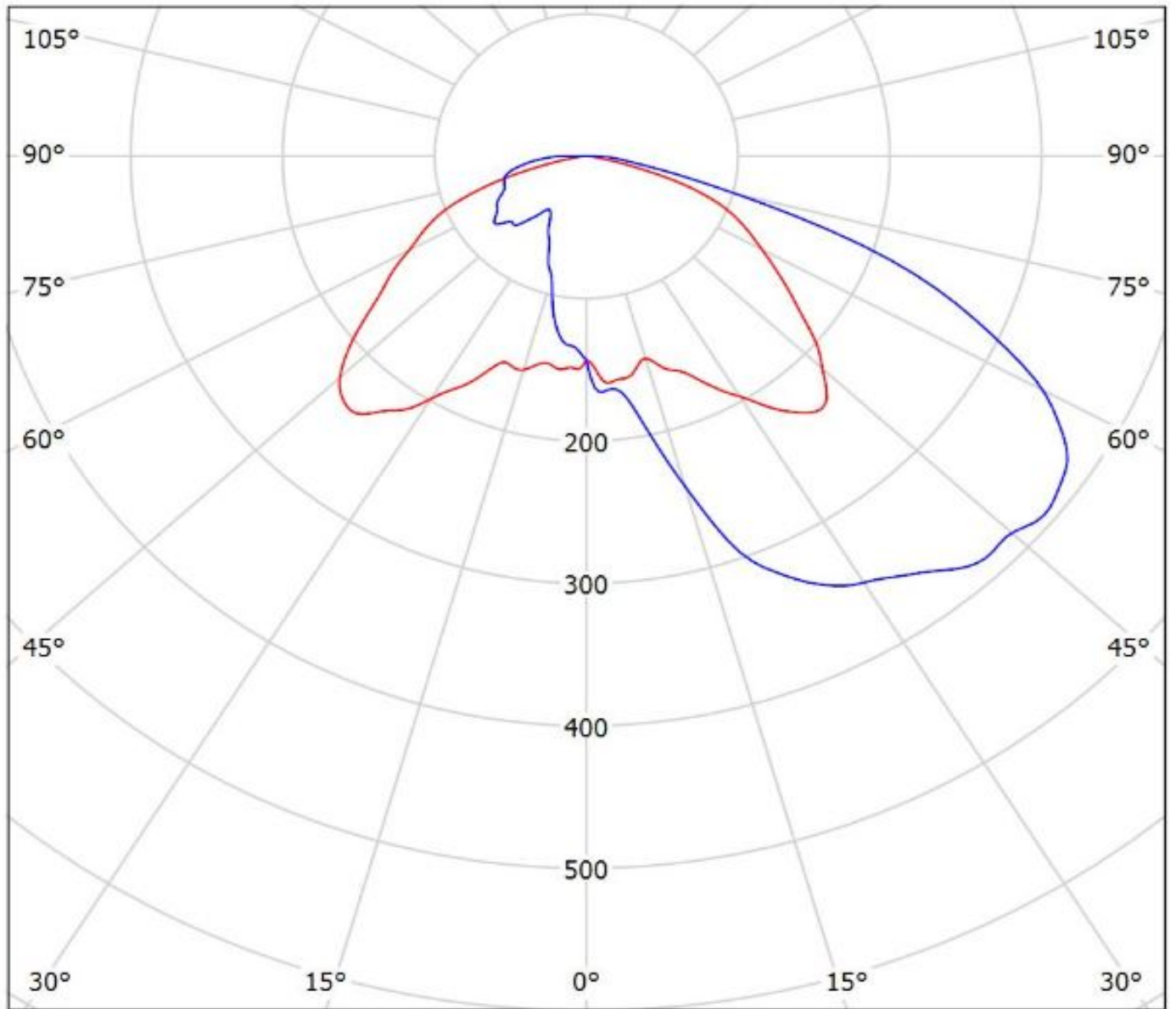

cd/klm
— C0 - C180 — C90 - C270

$\eta = 95\%$

Luminaire: Ledil Oy C13805_STRADA-2X2-T4_(Duris S5 (2chip))_SIMULATED
Lamps: 1 x Osram Duris S5 2chip

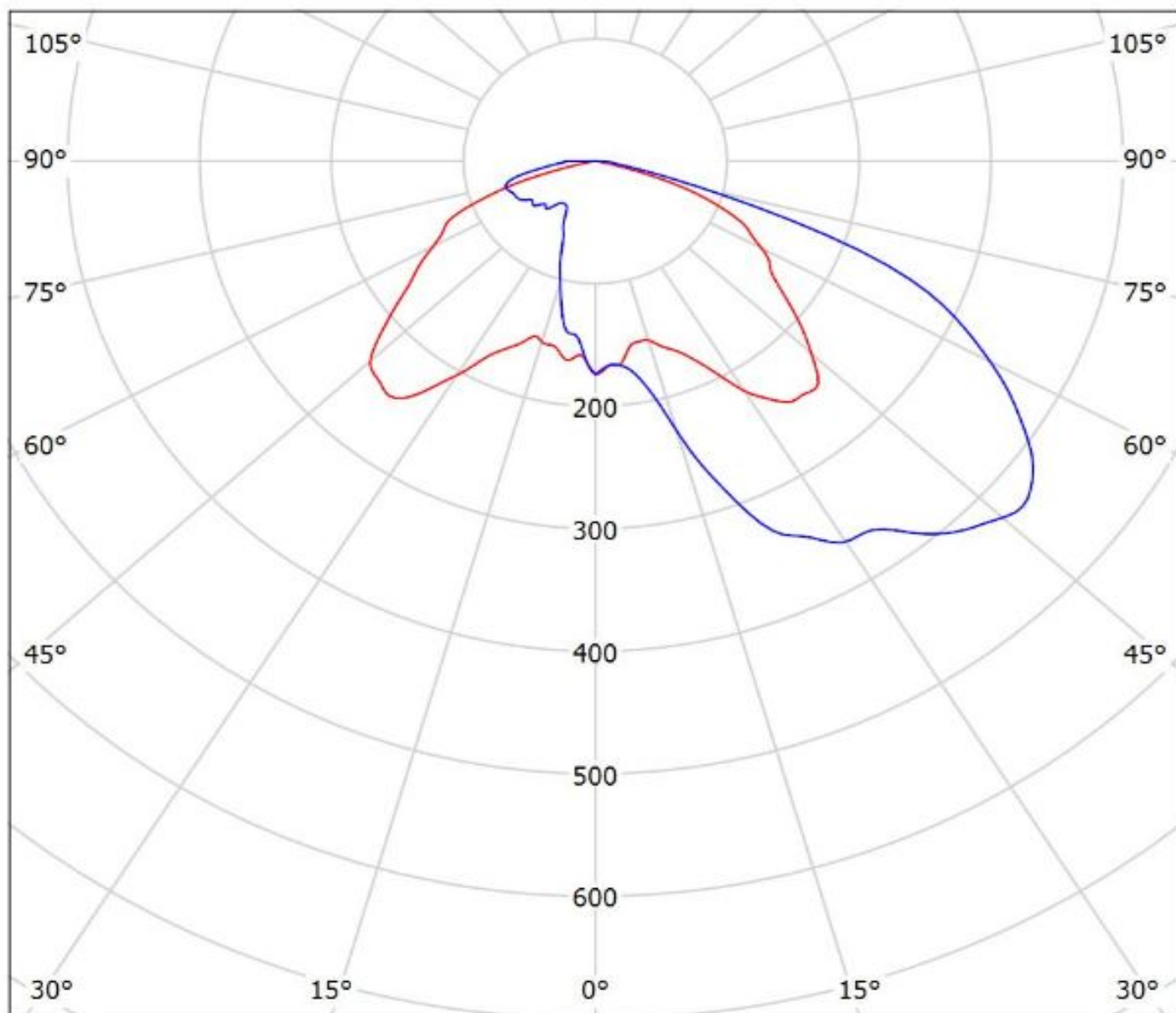

cd/klm

— C0 - C180 — C90 - C270

$\eta = 96\%$

Luminaire: Ledil C13805_STRADA-2X2-T4_(Fortimo_FastFlex_LED_board_2x8/740_DA_G3)
Lamps: 1 x Fortimo_FastFlex_LED_board_2x8/740_DA_G3_1828.23lm@250mA_P=11.667W_I=0.25A

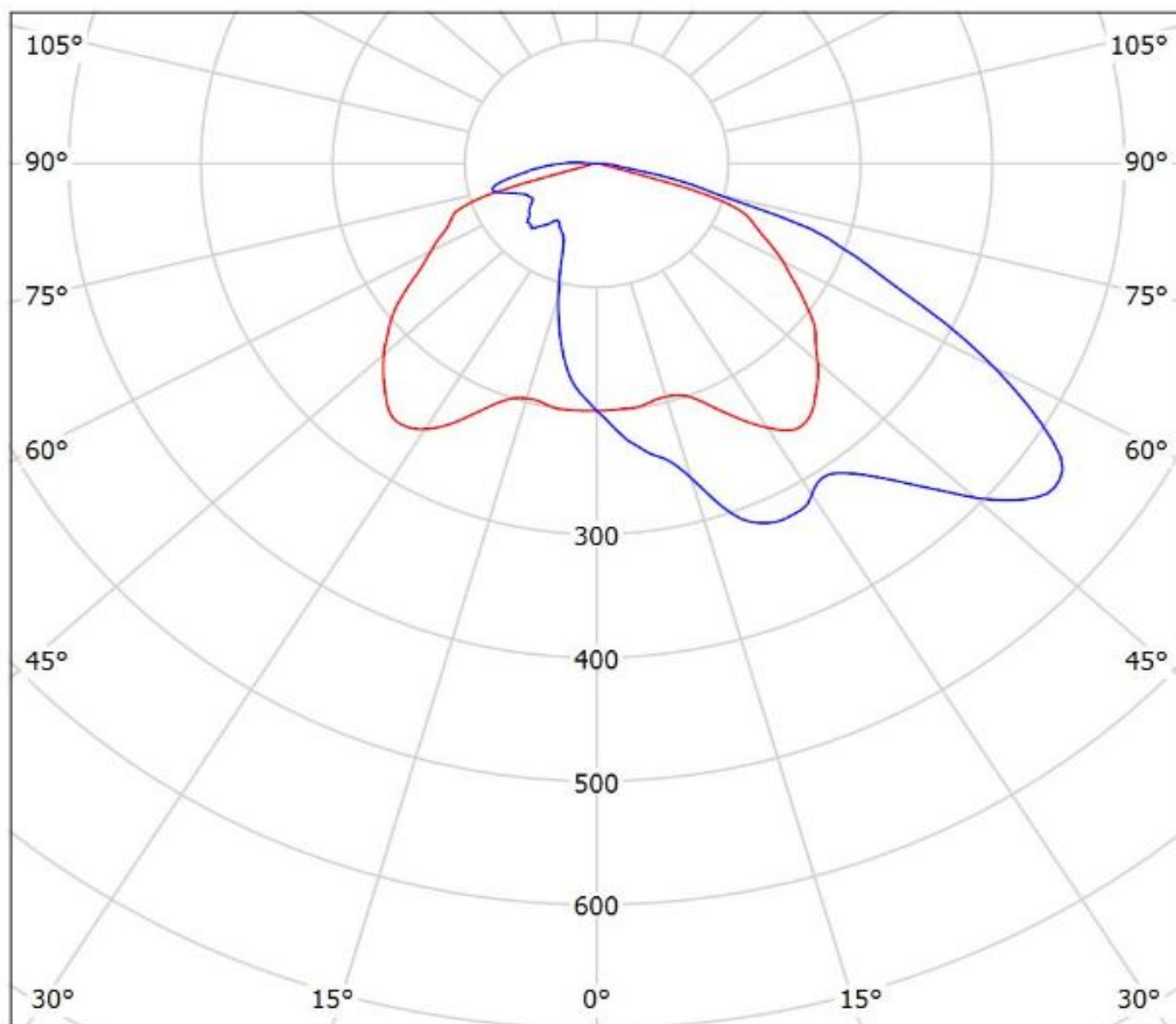

cd/klm
— C0 - C180 — C90 - C270

η = 97%

Luminaire: Ledil C13805_STRADA-2X2-T4_(Fortimo FastFlex LED board 2x8 DAX G4)
Lamps: 1 x Fortimo FastFlex LED board 2x8 DAX G4

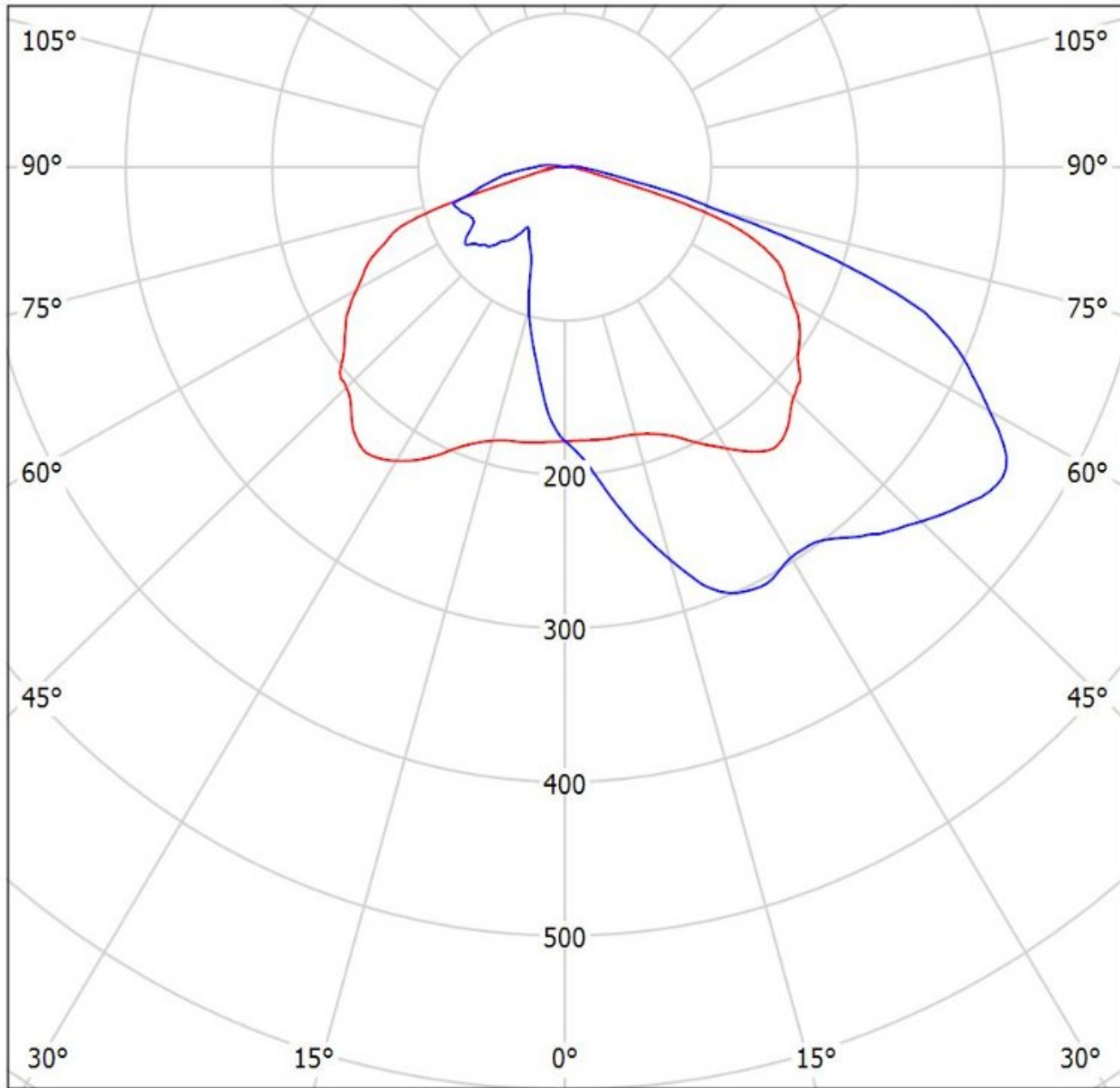

cd/klm

$\eta = 97\%$

— C0 - C180 — C90 - C270

Luminaire: Ledil C13805_STRADA-2X2-T4_(LH351B)

Lamps: 1 x Samsung_LH351B_2x2_444.178lm@250mA_P=2.8535W_I=0.25A

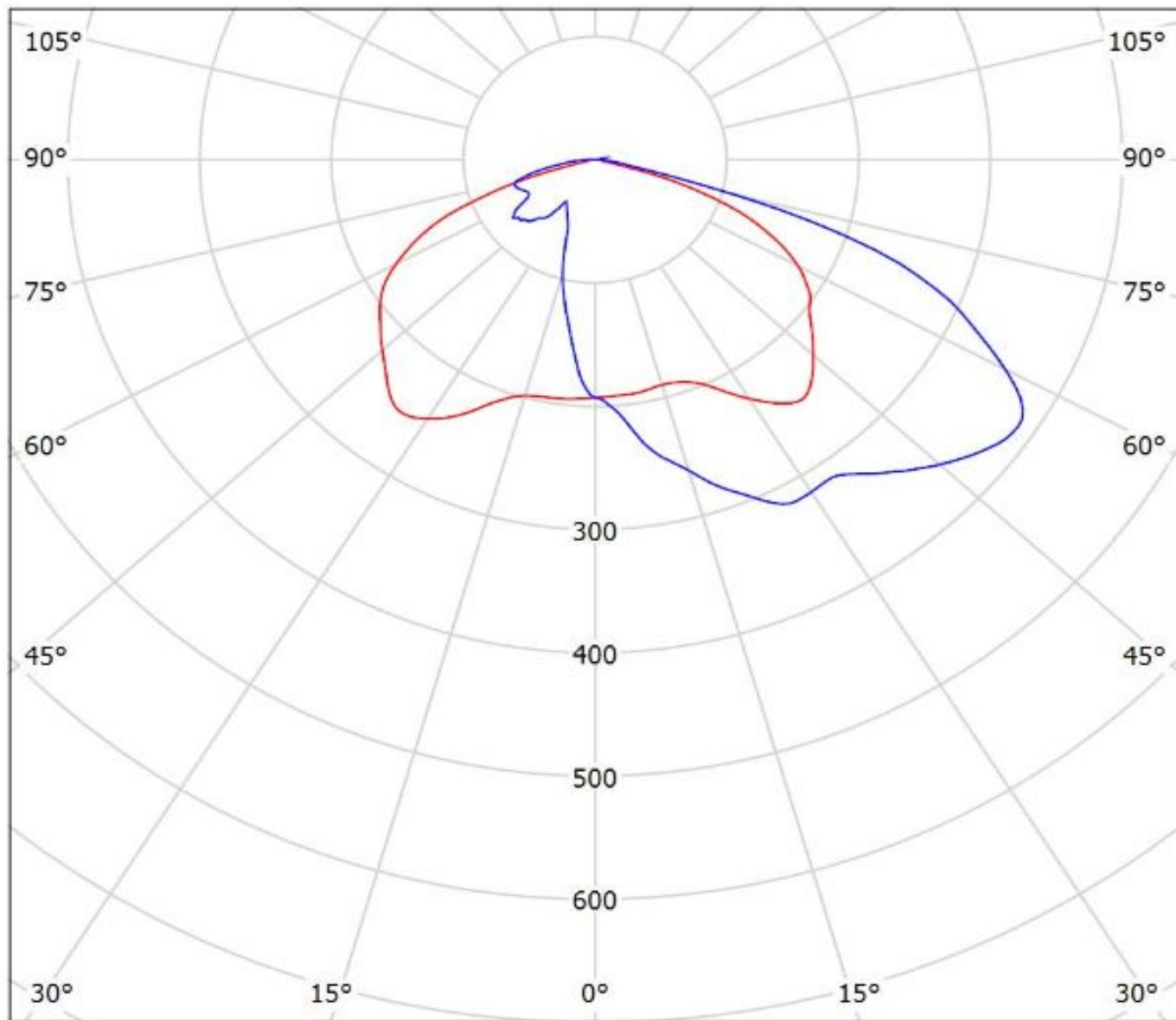

cd/klm

— C0 - C180 — C90 - C270

$\eta = 97\%$

Luminaire: Ledil C13805_STRADA-2X2-T4_(Z8Y22plus)

Lamps: 1 x Seoul_Z8Y22plus_(W6E2G)_513.996lm@250mA_P=2.754W_I=0.250A

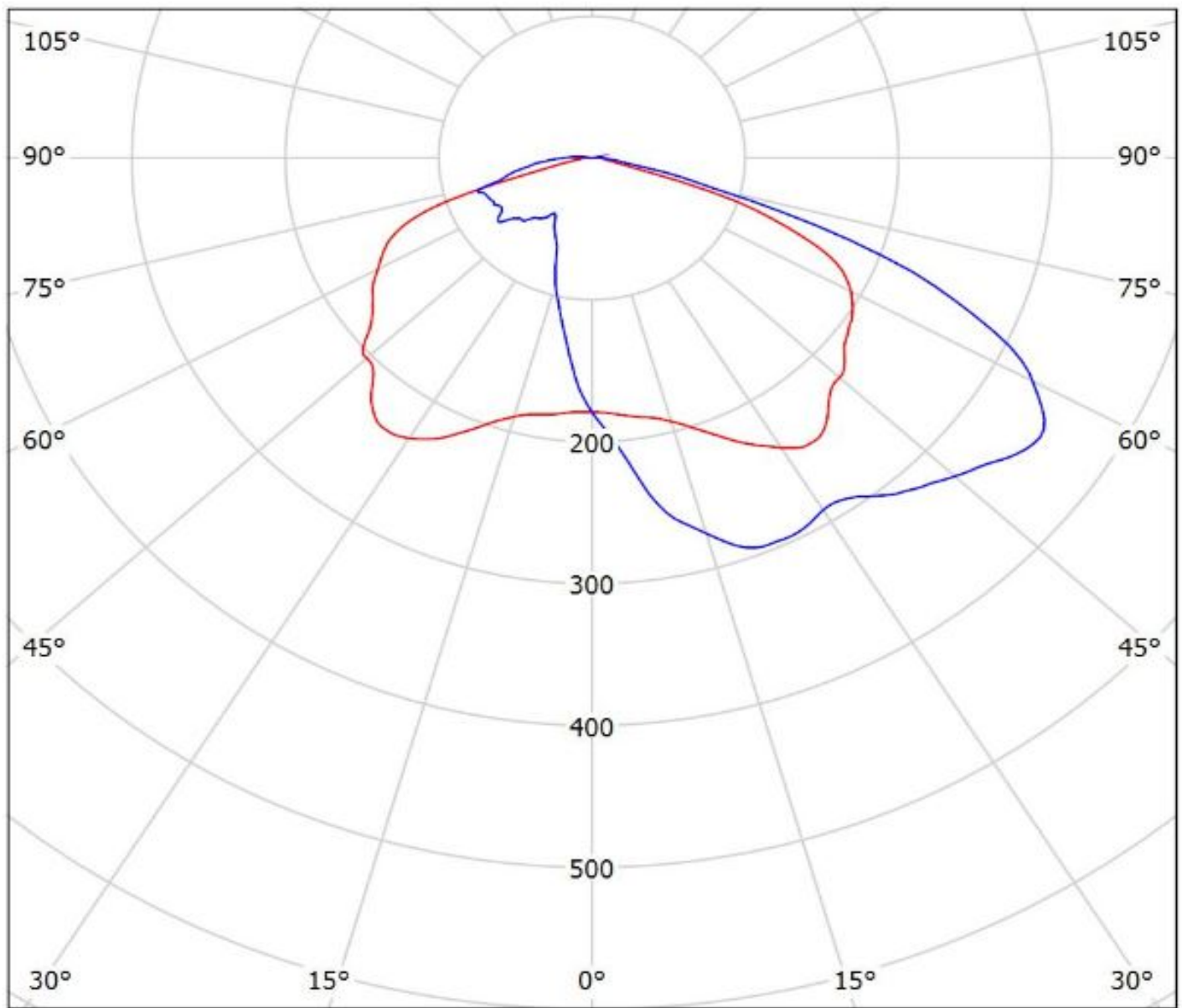

cd/klm

— C0 - C180 — C90 - C270

$\eta = 97\%$

Luminaire: LEDiL Oy C13805_STRADA-2X2-T4_(Z8Y22)

Lamps: 1 x Seoul_Wicop_Z8Y22_497.373lm@250mA_P=2.80076W_U=11.211V

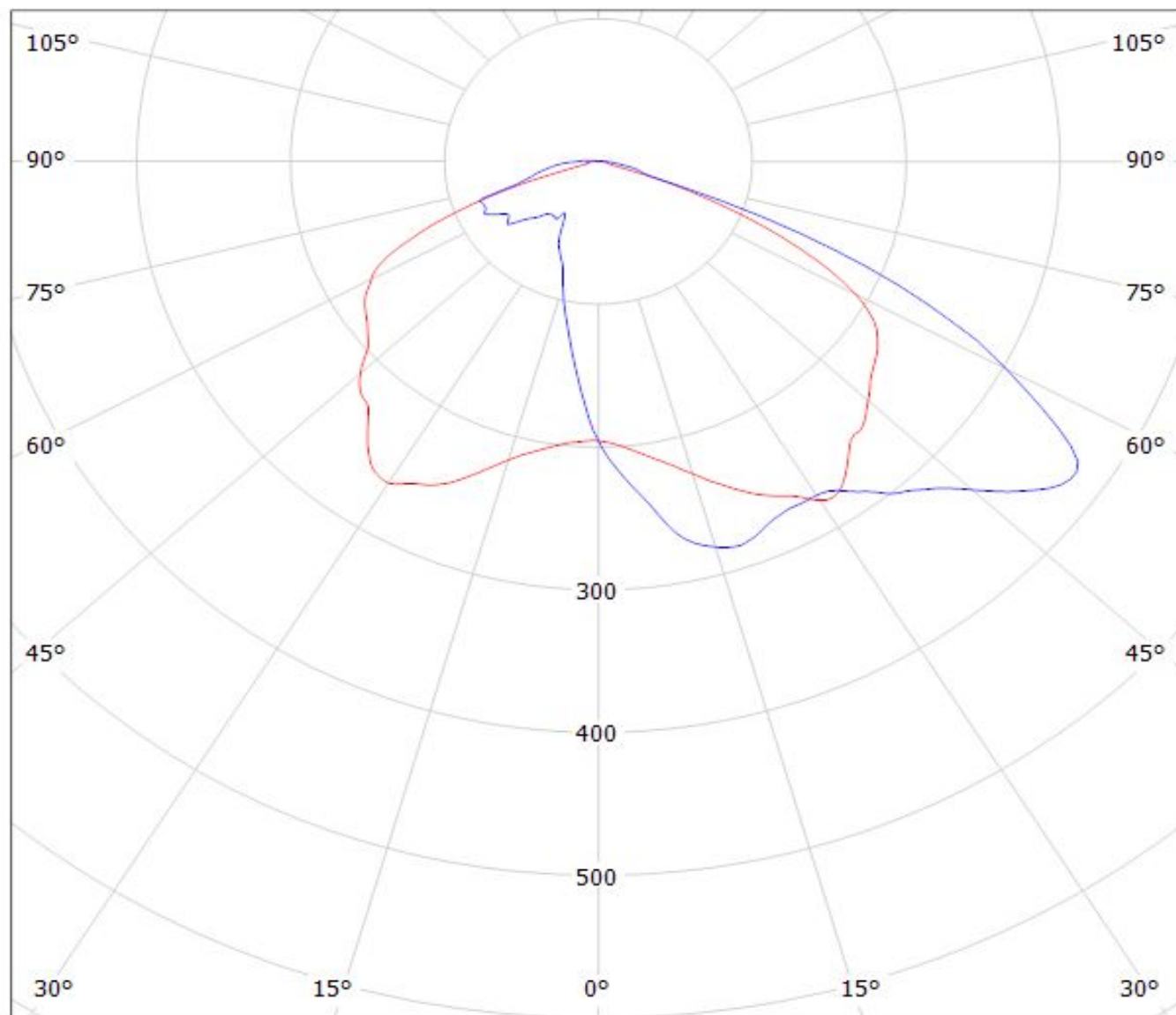

cd/klm

— C0 - C180

— C90 - C270

$\eta = 97\%$

Ledil C13805_STRADA-2X2-T4_(TL1L4) / LDC (Polar)

Luminaire: Ledil C13805_STRADA-2X2-T4_(TL1L4)

Lamps: 1 x Toshiba_TL1L4_2x2_(TL1L4-DW0)_472.639lm@250mA_CCT=6500K_P=2.9W_I=0.25A

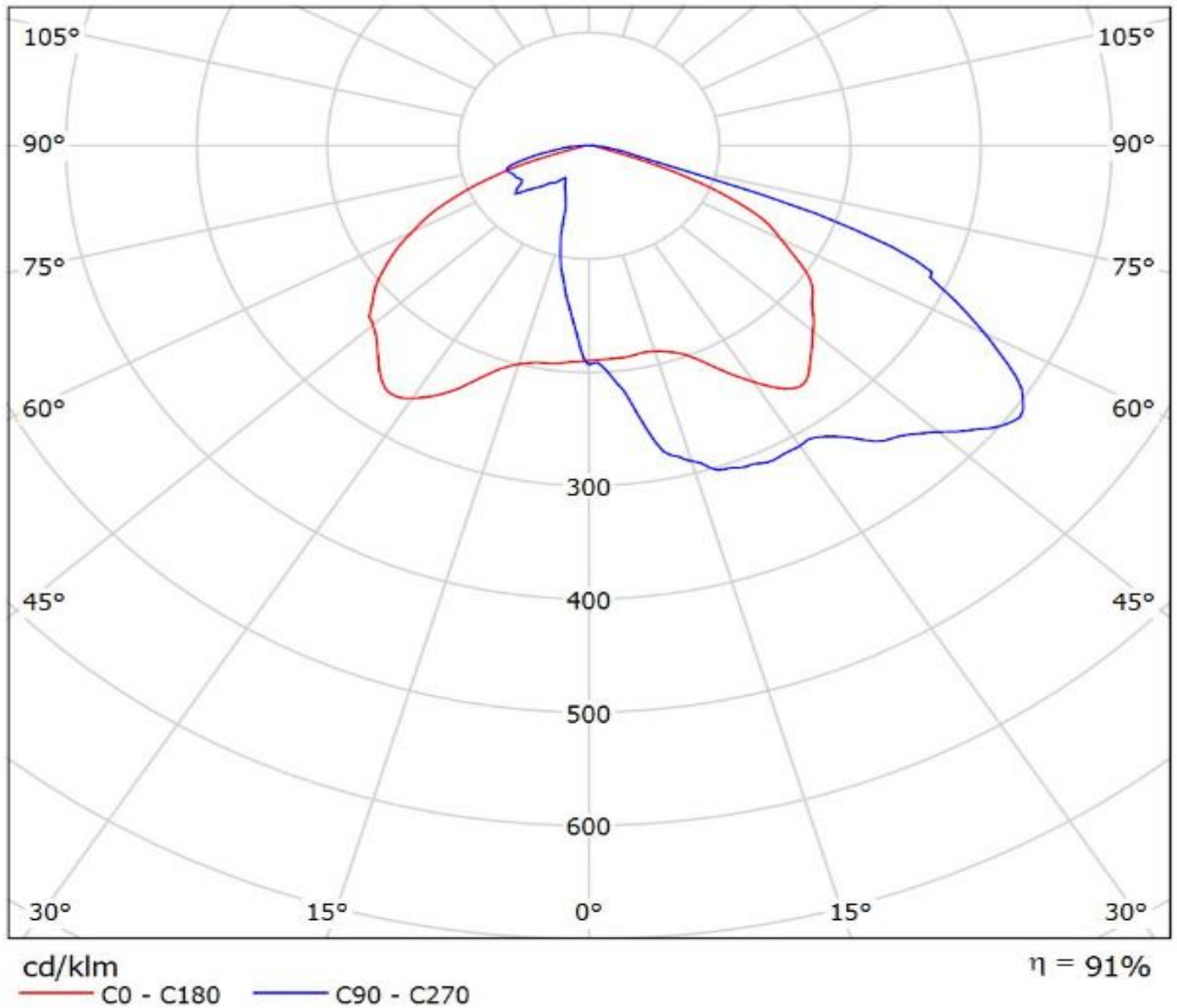

Luminaire: LEDiL Oy C13805_STRADA-2X2-T4_(Tridonic_Module_RLE_G1)
Lamps: 1 x Tridonic_Module_RLE_G1_4576.03lm@700mA_P=32.0681W_I=0.700A

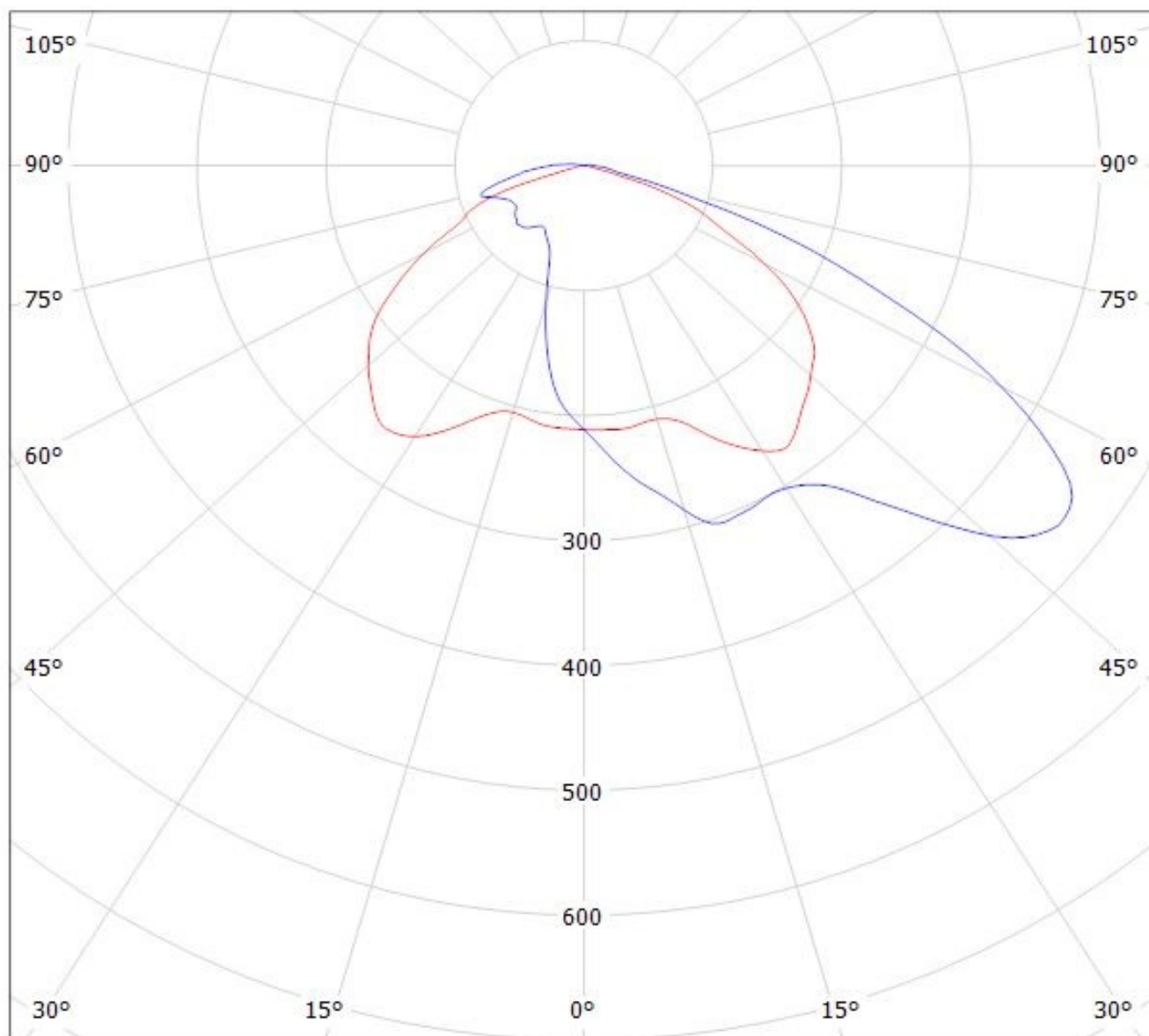

cd/klm

$\eta = 94\%$

— C0 - C180 — C90 - C270

Luminaire: LEDiL Oy C13805_STRADA-2X2-T4_(Tridonic_Module_RLE_G1)
Lamps: 1 x Tridonic_Module_RLE_G1_4576.03lm@700mA_P=32.0681W_I=0.700A

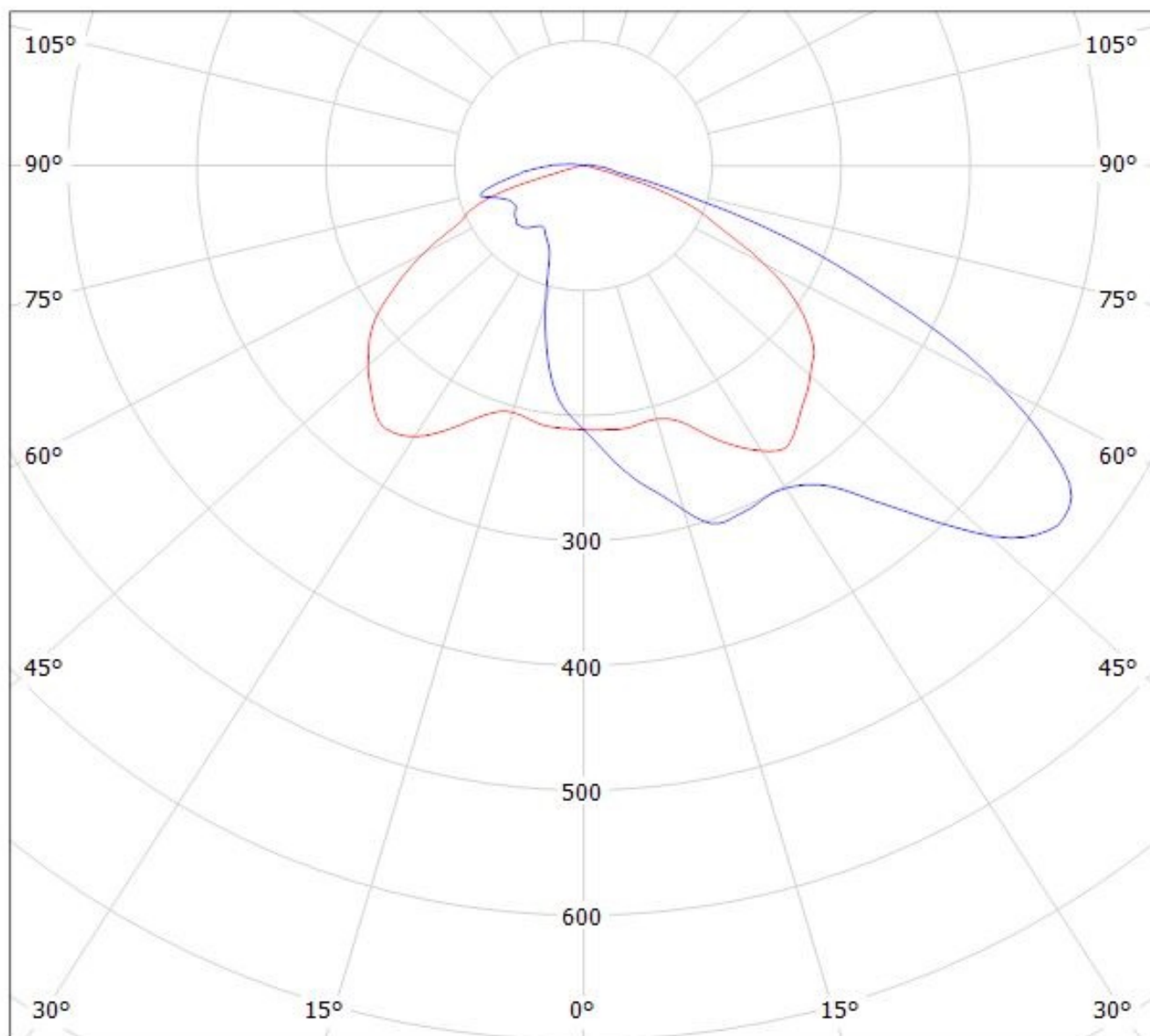

cd/klm

$\eta = 94\%$

— C0 - C180 — C90 - C270

Luminaire: LEDiL Oy C13805_STRADA-2X2-T4_(Tridonic_Module_RLE_G1)
Lamps: 1 x Tridonic_Module_RLE_G1_2288lm@700mA_P=16W_I=0.700A

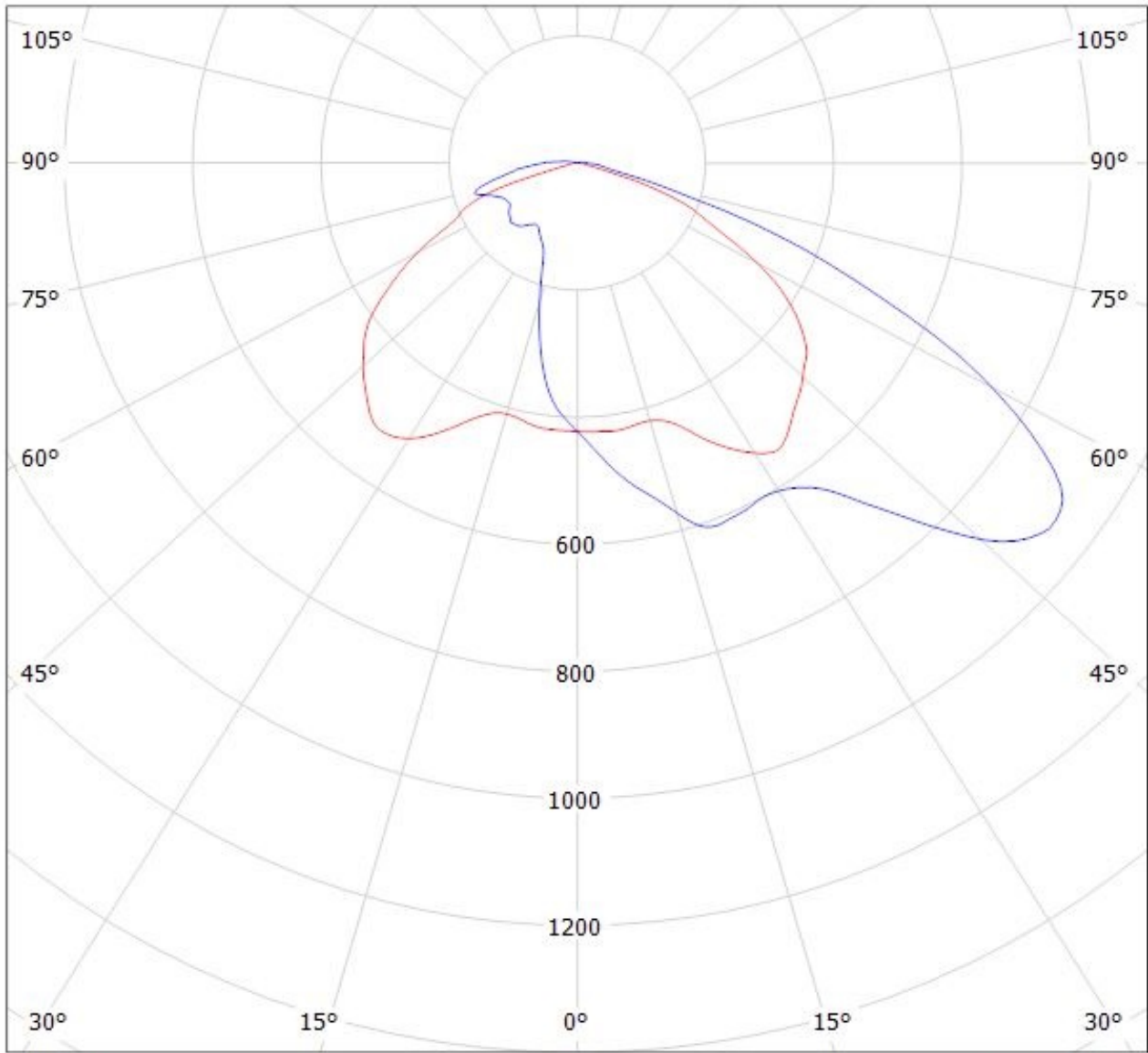

cd/klm

— C0 - C180 — C90 - C270

$\eta = 94\%$

Luminaire: LEDiL Oy C13805_STRADA-2X2-T4_(Tridonic_Module_RLE_G1)
Lamps: 1 x Tridonic_Module_RLE_G1_2288lm@700mA_P=16W_I=0.700A

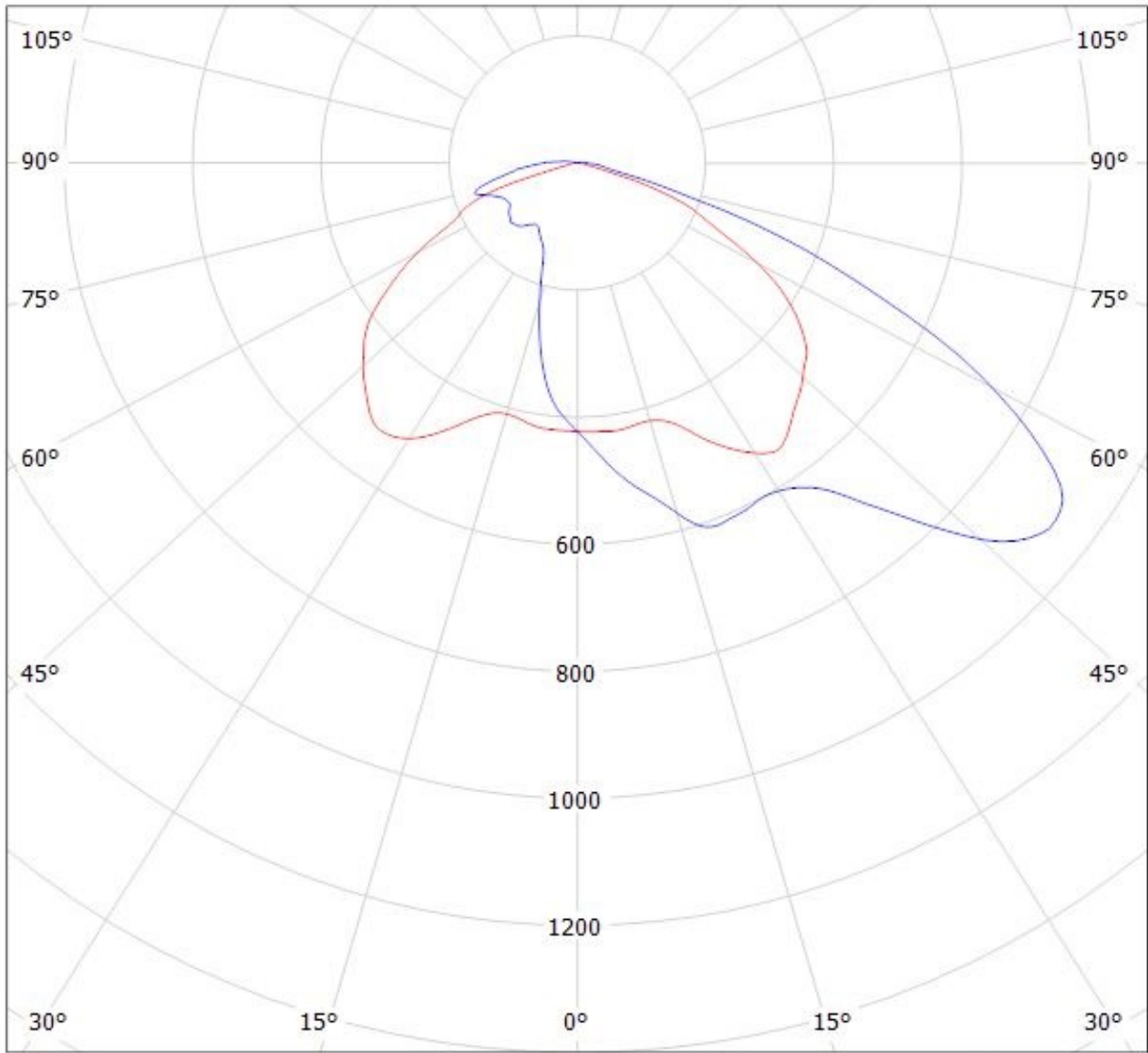

cd/klm

— C0 - C180 — C90 - C270

$\eta = 94\%$

NOTE: The typical divergence will be changed by different color, chip size and chip position tolerance. The typical total divergence is the full angle measured where the luminous intensity is half of the peak value.