

CS-300

Clock Smoother



Features

- Output frequencies up to 800 MHz
- Ultra Low Jitter PECL Output
- Locks to Input Frequency (i.e. 622.08 MHz)
- 3.3 Vdc or 5.0 Vdc supply
- Lock / Loss of Signal Alarm
- 1" x 0.8" x 0.25", Surface Mount (FR4 base)

Applications

- Clock Smoothing
- SONET / SDH / ATM / DWDM / SFI-5
- FEC (Forward Error Correction)
- 622.08 MHz to 622.08 MHz

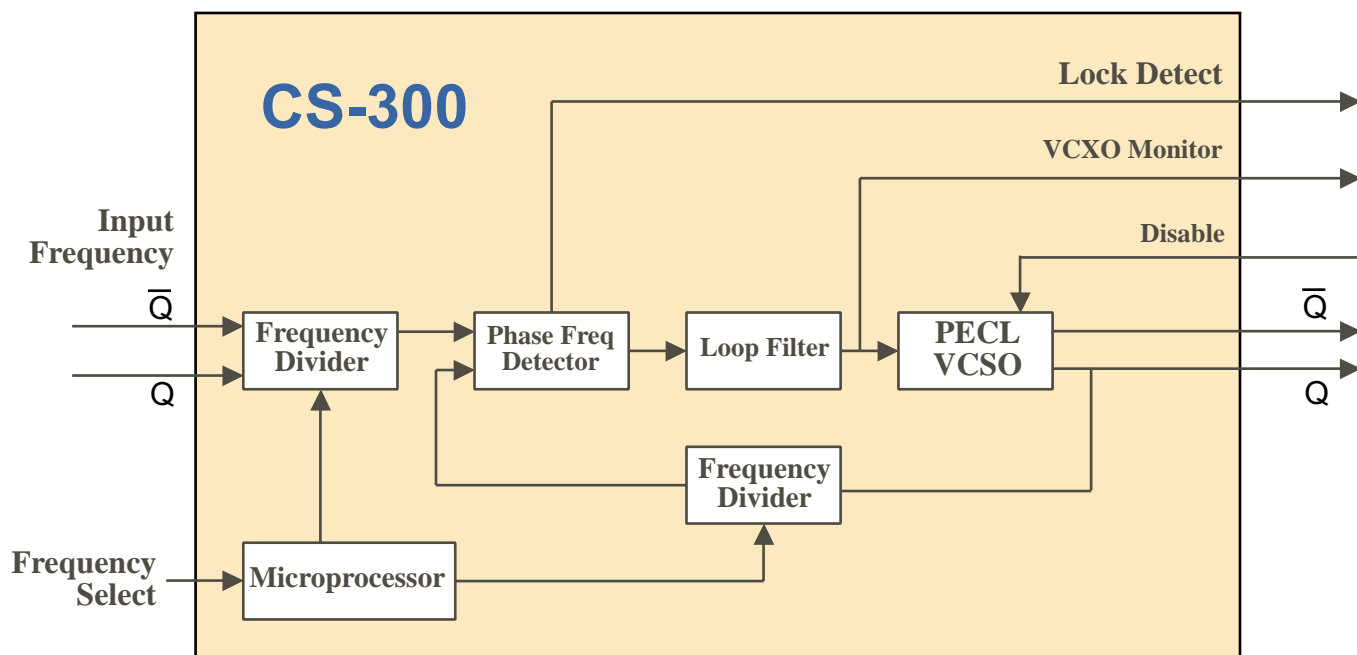

CS-300 Clock Smoother

Description

Vectron's CS-300 is a SAW based Clock Smoother and Frequency Translator which is used to "clean up" noisy input frequencies. This series can accept any input frequency from 10 MHz to 700 MHz and then "cleans up" up the signal to provide an ultra low jitter output signal. The output jitter of this unit is well below the requirements of OC-192.

The CS-300 also has the ability to translate either one or two different input frequencies between 10 MHz and 700 MHz to one common output frequency, such as input frequencies of 622.08 MHz and 666.5143 MHz translated to an output frequency of 622.08 MHz. This unit is of particular interest to those working with FEC applications or needing to switch between 10G and OC-192.

The "Input Frequency Tracking Capability" is the total amount of frequency deviation on the input signal that the CS-300 is guaranteed to track. As an example, a typical input clock would be 622.08 MHz \pm 20 ppm. The CS-300 is guaranteed to track at least \pm 40 ppm of error over temperature/ aging/ power supply and is more than twice what most applications require.

Performance Characteristics

Parameter	Symbol	Minimum	Typical	Maximum	Units
Supply Voltage, C = 5 Vdc D = 3.3 Vdc	V _{cc} V _{cc}	4.75 3.135	5.00 3.30	5.25 3.465	Vdc Vdc
Supply Current 5 Vdc 3.3 Vdc	I _{cc} I _{cc}		135 115	200 200	mA mA
Input Signal, F = Comp PECL	CLKIN	10 MHz	PECL	700 MHz	---
Output F = Comp PECL	---	155.52 MHz	PECL	800 MHz	---
V _{OL} @ +25°C	V _{OL}	V _{cc} -1.95		V _{cc} -1.63	V
V _{OH} @ +25°C	V _{OH}	V _{cc} -0.98		V _{cc} -0.75	V
Rise / Fall Time (20% to 80% @ 622.08 MHz)	t _R /t _F		250	400	ps
Output Symmetry	Sym	45	49/51	55	%
Jitter Generation, rms (12kHz to 20MHz)			0.23	1.0	ps
Jitter Generation, rms(cycle to cycle method)			3		ps
Jitter Transfer, GR-253-CORE section 5.6.2.1.2				0.1	dB
Input Frequency Tracking Capability (Can translate a Stratum 1,2,3,3E,4 or SONET Min source)	APR	+/-40			ppm
Operating Temperature	Temp Range C = 0°C to +70°C Temp Range F = -40°C to +85°C				
Size	See page 3 for outline Drawings and Dimensions				

CS-300 Clock Smoother

Outline Drawing

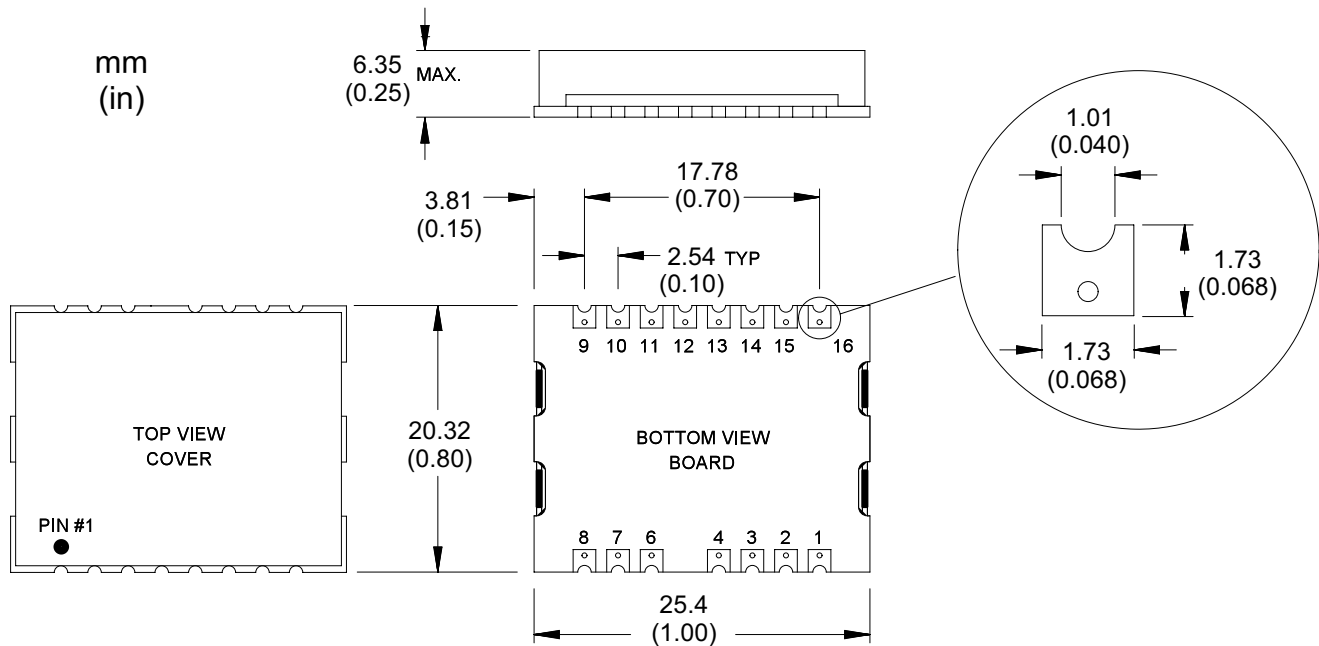

Pin	Symbol	Function
1	CLKIN Q	Input Frequency (Q)
2	CLKIN \bar{Q}	Complementary Input Frequency (\bar{Q})
3	LD (Output)	Lock Detect Logic "1" indicates a locked condition. Logic "0" indicates an out of lock condition.
4	Monitor (Output)	PLL/ VCXO control voltage Under locked conditions, should be >0.3V and <3.0V for the 3.3 volt option or >0.5V and <4.5V for the 5 volt option. Input frequency may be out of range if voltage exceeds these limits.
5	----	Missing
6	NC	No Connection
7	GND	Ground
8	Disable (Input)	Floating = Output enabled Logic "0" = Output disabled
9	OUT	Output (Q)
10	COUT	Complementary Output (\bar{Q})
11	NC	No Connection
12	Freq. Select	"0" = Primary Frequency "1" = Secondary Frequency (Do not Exceed Vdd)
13	NC	No Connection
14	NC	No Connection
15	GND	Ground
16	V _{cc}	5 Vdc or 3.3 Vdc

CS-300 Clock Smoother

Recommended Pad Layout

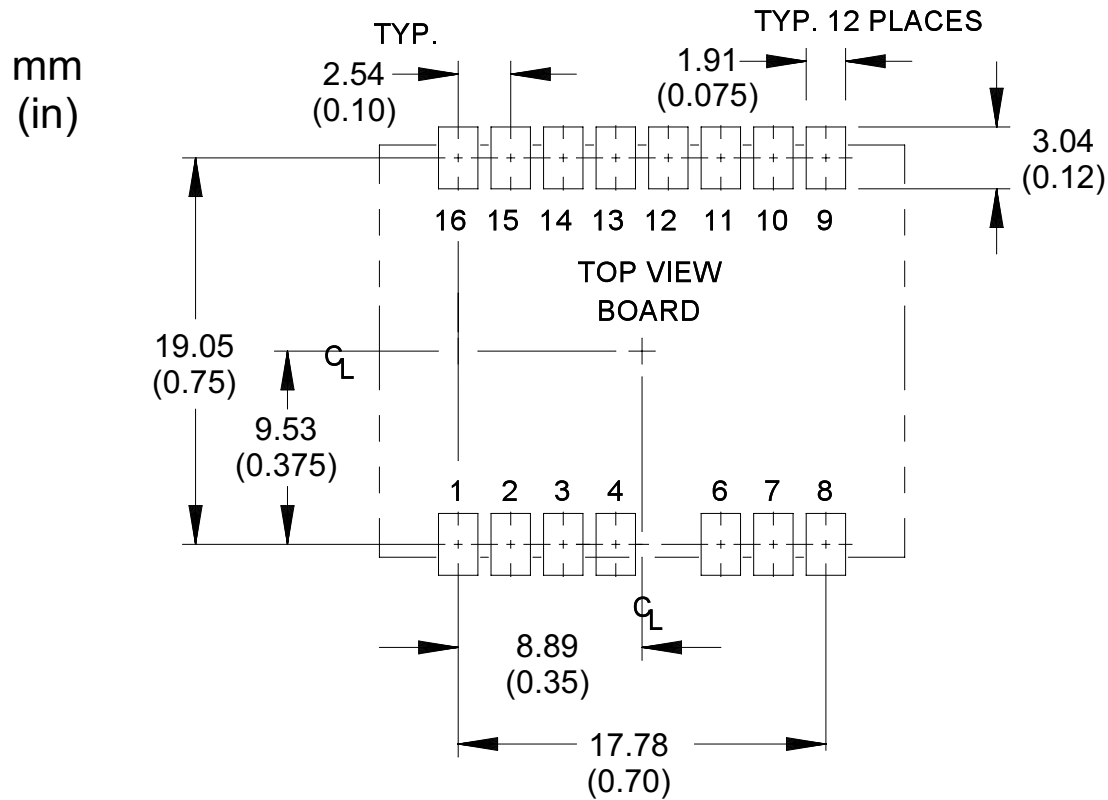

Recommended Reflow Profile

Convection Reflow Profile

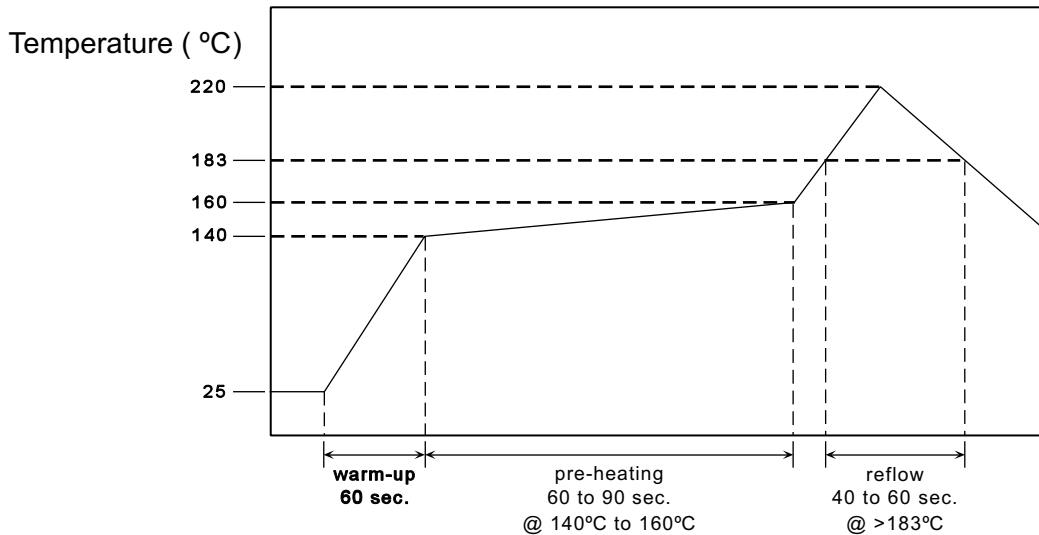

NOTE: The CS-300 should not be subjected to a wash process that will immerse it in solvents. NO CLEAN is the recommended procedure. The CS-300 has been designed for pick and place reflow soldering. The suggested reflow profile is shown above. The CS-300 may be reflowed once, and should not be reflowed in the inverted position.

CS-300 Clock Smoother

Standard Shipping Method

The Standard ship method for volume production of the CS-300 series is in a matrix tray. These trays are 100% recyclable. The trays also offer the added feature that they can be continuously feed into a pick-n-place machine eliminating the down time required with tape-n-reel.

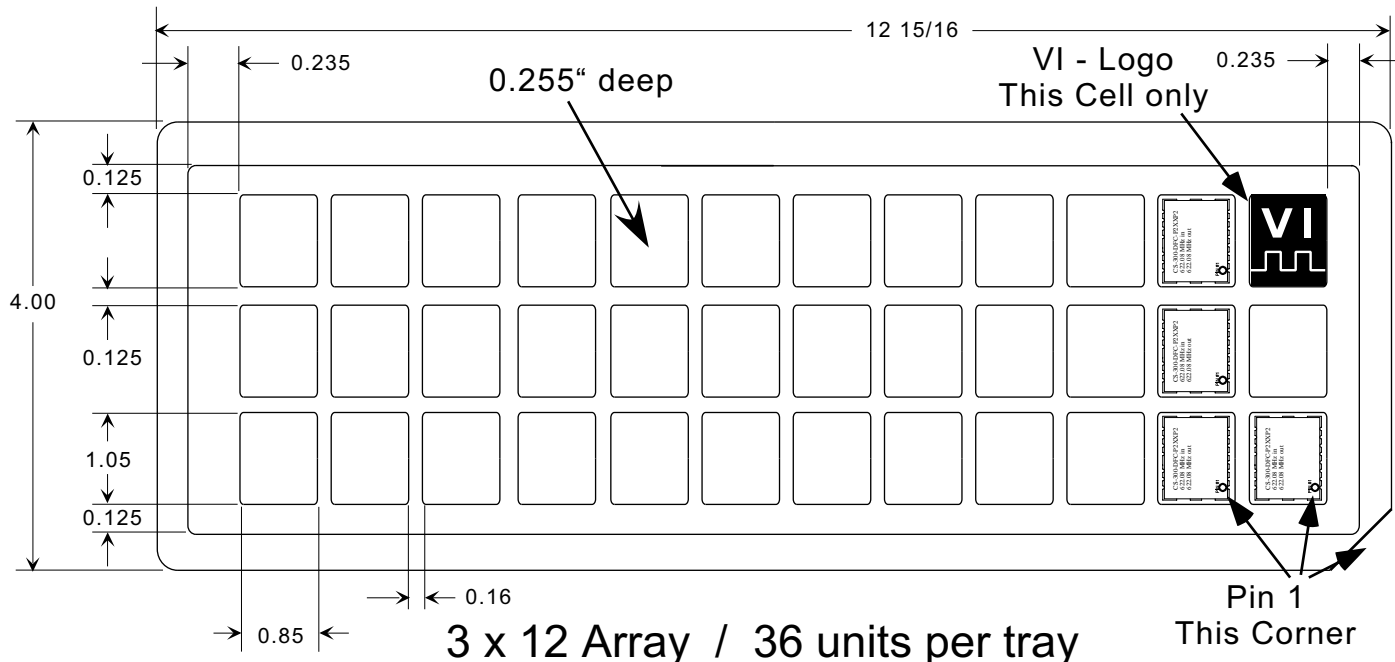

Handling Precautions

Although protection circuitry has been designed into this device, proper precautions should be taken to avoid exposure to electrostatic discharge (ESD) during handling and mounting. VI employs a human-body model (HBM) and a charged-device model (CDM) for ESD-susceptibility testing and protection design evaluation. ESD voltage thresholds are dependent on the circuit parameters used to define the mode.

Although no industry-wide standard has been adopted for the CDM, a standard HBM (resistance = 1500 ohms, capacitance = 100pf) is widely used and therefore can be used for comparison purposes. The HBM ESD threshold presented here was obtained by using these circuit parameters.

ESD Threshold Voltage		
Model	Threshold	Unit
Human-Body (HBM)	500	V min
Charged-Device	500	V min

CS-300 Clock Smoother

Typical Application

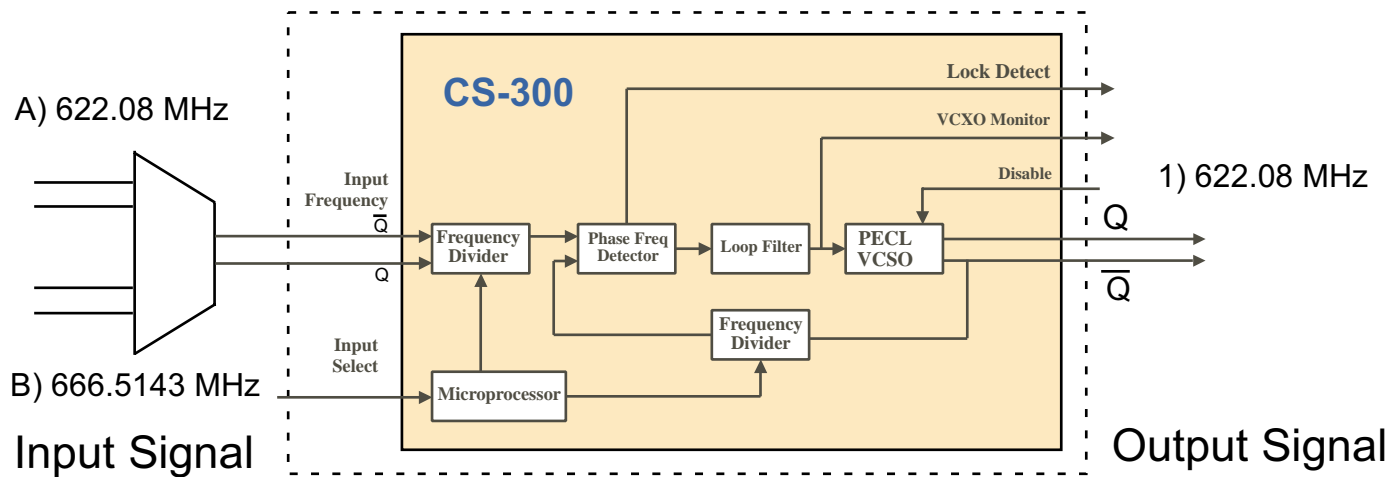

Input Select	Description of Action
0	A to 1 :Translates 622.08 MHz to 622.0800 MHz
1	B to 1 :Translates 666.5143 MHz to 622.08 MHz

All components outside the dotted line box are user supplied components and/or connections. This is just one possible configuration of the CS-300. For additional information about your specific needs please contact our Factory.

Output Load Configuration

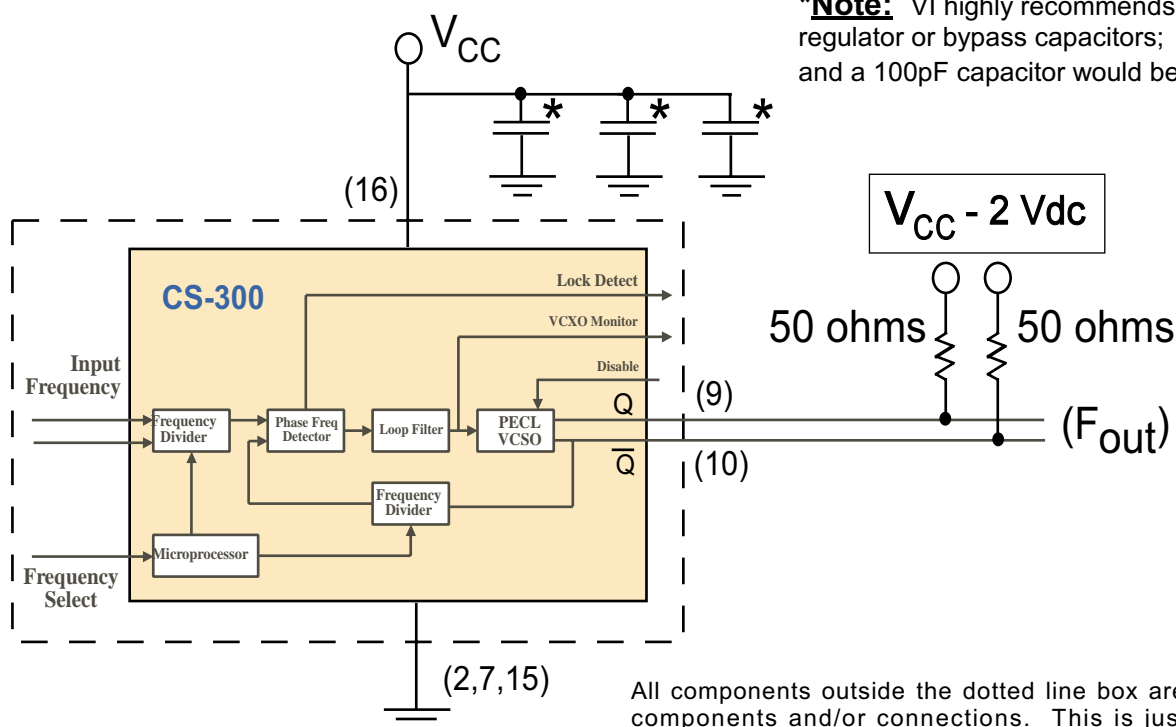

***Note:** VI highly recommends either a linear regulator or bypass capacitors; 10 uF, 0.1 uF and a 100pF capacitor would be typical.

All components outside the dotted line box are user supplied components and/or connections. This is just one possible configuration of the CS-300. For additional information about your specific needs please contact our Factory.

CS-300 Clock Smoother

Evaluation Board

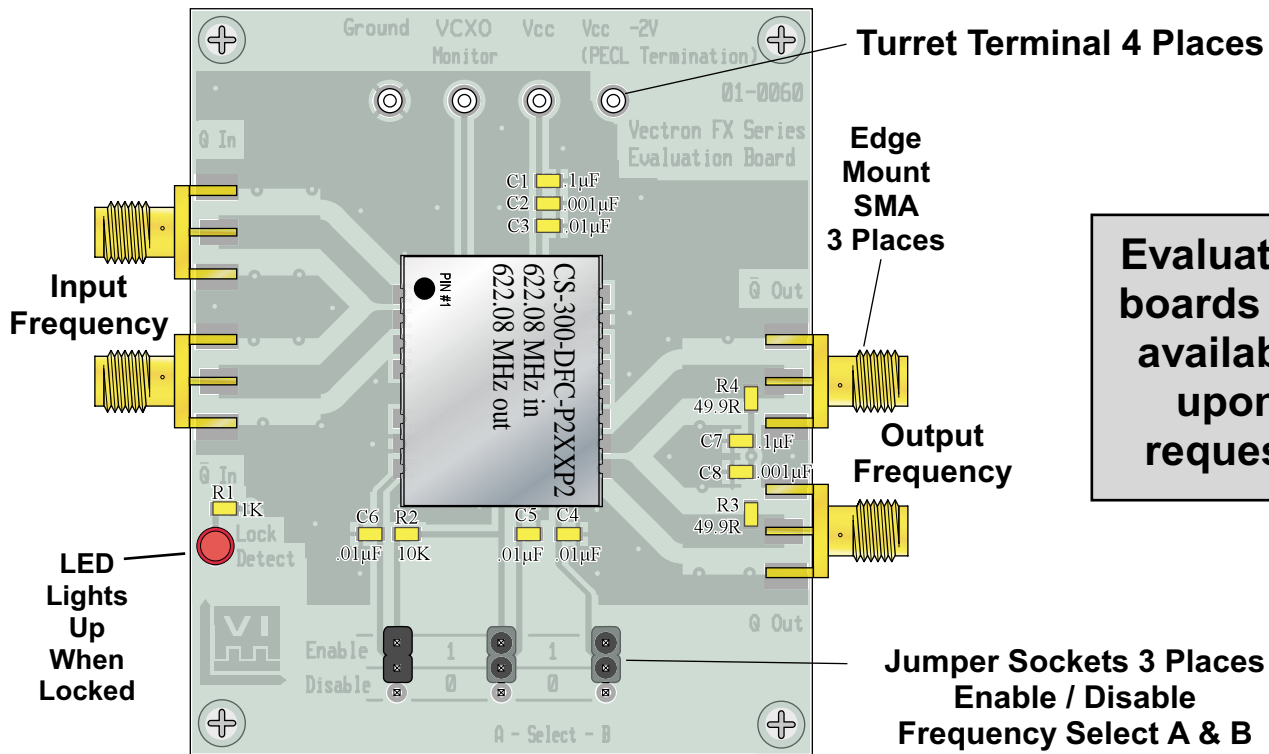

FAQ's

Q1: What are the different input frequencies available?

A: The CS-300 is able to handle any input frequency between 10 MHz and 700 MHz.
(A list of standard frequencies is available on page 8.)

Q2: How many different input frequencies can a specific CS-300 accept?

A: Each CS-300 can be programmed to accept up to 2 different input frequencies.

Q3: If there is only one set of input pins, how can your unit accept 2 different frequencies?

A: The customer is required to supply a multiplexer which would switch between the different input frequencies. The multiplexers' select pin would need to be sync'd to the select pin of the CS-300.

Q4: What is the lock time for the CS-300?

A: The exact lock time will depend on the specific input frequency. It should be noted that in all cases the lock time will be significantly less than 1 second.

Q5: What type of noise on the supply line can the CS-300 suppress?

A: The CS-300 is designed to clean up noise on the Input Clock Signal, it is not designed to clean up noisy power supplies. If excessive noise is present on the supply line it may degrade the output jitter performance. Additional external filtering may be required. Please consult with your power supply vendor on the best way to filter noise of your supply line.

CS-300 Clock Smoother

Standard Frequencies

10.000 MHz	C4	38.8800 MHz	H5	139.264 MHz	L5	669.1281 MHz	R2
12.800 MHz	D2	44.4343 MHz	J2	155.520 MHz	M2	669.3266 MHz	R3
13.000 MHz	D3	44.7360 MHz	J3	156.250 MHz	M3	669.6428 MHz	R1
15.000 MHz	D4	51.8400 MHz	J4	161.1328 MHz	M4	672.1627 MHz	R5
16.384 MHz	D5	61.4400 MHz	J5	166.6286 MHz	M5	690.5692 MHz	R4
19.440 MHz	D6	65.5360 MHz	J6	167.3316 MHz	N2	693.4830 MHz	R6
20.0000 MHz	E2	74.1250 MHz	K1	168.0407 MHz	N3	710.9486 MHz	T2
20.1416 MHz	E3	74.2500 MHz	K7	311.0400 MHz	P1	719.7344 MHz	T3
20.4800 MHz	E4	77.7600 MHz	K2	622.0800 MHz	P2	777.6000 MHz	T4
22.2171 MHz	E5	78.1250 MHz	K3	624.7048 MHz	P6		
26.0000 MHz	F3	78.6432 MHz	K5	625.0000 MHz	P3		
27.0000 MHz	F4	82.9440 MHz	K6	627.3296 MHz	P7		
29.4912 MHz	F5	112.000 MHz	L2	644.5313 MHz	P4	No Second Input Freq	XX
32.7680 MHz	H3	114.000 MHz	L3	666.5143 MHz	P5	Input Freq not listed	SS
37.0560 MHz	H4	125.000 MHz	L4			Output Freq not listed	SS

How to Order

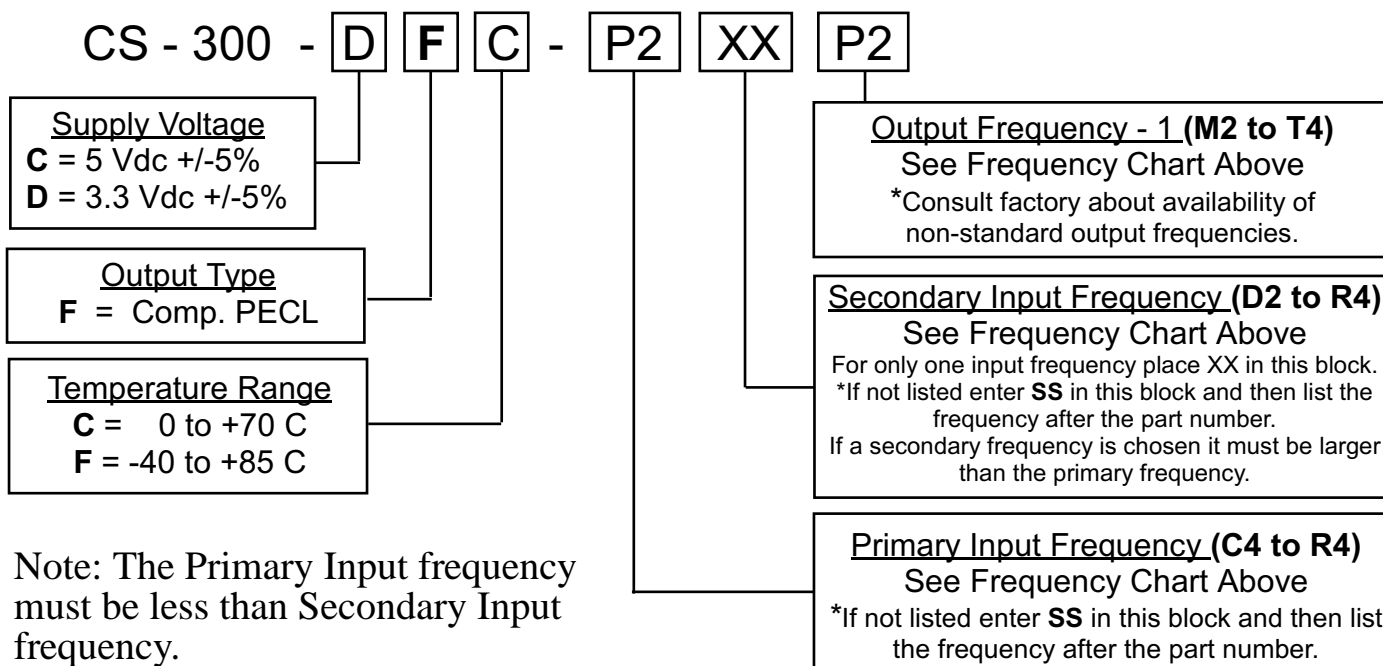

Note: The Primary Input frequency must be less than Secondary Input frequency.

*A special part number will be assigned for these cases.

Visit Our Website at www.vectron.com

For additional information please contact:



USA: Vectron International * 267 Lowell Road, Hudson, NH 03051.... Tel: 1-88-VECTRON-1 * Fax: 1-888-FAX-VECTRON

EUROPE:..... Tel: 49 (0) 3328 4784 17 * Fax: 49 (0) 3328 4784 30

www.vectron.com

ASIA: 28909740 / 41 / 42 Fax: +86 21-28909240 / 28909999