

32-Tap Digital Potentiometer (DP)

Description

The DP7114 is a single digital potentiometer (DP) designed as an electronic replacement for mechanical potentiometers and trim pots. Ideal for automated adjustments on high volume production lines, they are also well suited for applications where equipment requiring periodic adjustment is either difficult to access or located in a hazardous or remote environment.

The DP7114 contains a 32-tap series resistor array connected between two terminals R_H and R_L . An up/down counter and decoder that are controlled by three input pins, determines which tap is connected to the wiper, R_W . The wiper setting, stored in nonvolatile memory, is not lost when the device is powered down and is automatically reinstated when power is returned. The wiper can be adjusted to test new system values without affecting the stored setting. Wiper-control of the DP7114 is accomplished with three input control pins, \overline{CS} , U/\overline{D} , and \overline{INC} . The \overline{INC} input increments the wiper in the direction which is determined by the logic state of the U/\overline{D} input. The \overline{CS} input is used to select the device and also store the wiper position prior to power down.

The digital potentiometer can be used as a three-terminal resistive divider or as a two-terminal variable resistor. DPs bring variability and programmability to a wide variety of applications including control, parameter adjustments, and signal processing.

Features

- 32-position Linear Taper Potentiometer
- Non-volatile EEPROM Wiper Storage
- Low Standby Current
- Single Supply Operation: 2.5 V – 6.0 V
- Increment Up/Down Serial Interface
- Resistance Values: 10 k Ω , 50 k Ω and 100 k Ω
- Available in SOIC, TSSOP, MSOP and Space Saving 2 x 3 mm TDFN Packages
- These Devices are Pb-Free, Halogen Free/BFR Free and are RoHS Compliant

Applications

- Automated Product Calibration
- Remote Control Adjustments
- Offset, Gain and Zero Control
- Tamper-proof Calibrations
- Contrast, Brightness and Volume Controls
- Motor Controls and Feedback Systems
- Programmable Analog Functions



SOIC-8

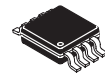

MSOP-8

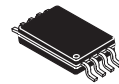

TSSOP-8



TDFN-8

PIN CONFIGURATIONS

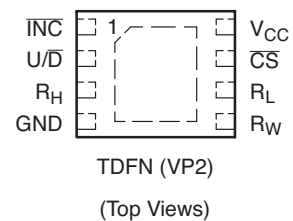
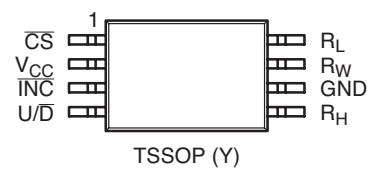
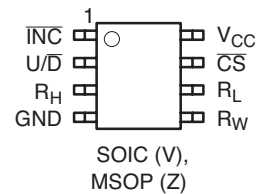

ORDERING INFORMATION

See detailed ordering and shipping information in the package dimensions section on page 15 of this data sheet.

DP7114

DEVICE MARKING INFORMATION

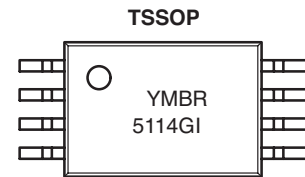
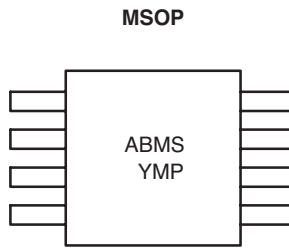
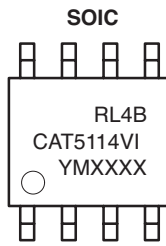

R = Resistance:
 2 = 10 kΩ
 4 = 50 kΩ
 5 = 100 kΩ
 L = Assembly Location
 4 = Lead Finish – NiPdAu
 B = Product Revision (Fixed as “B”)
 CAT5114V = Device Code
 I = Temperature Range (Industrial)
 Y = Production Year (Last Digit)
 M = Production Month
 (1–9, A, B, C or O, N, D)
 XXXX = Last Four Digits of Assembly Lot Number

ABMS = DP7114ZI–10–GT3
 ABMT = DP7114ZI–50–GT3
 ABTH = DP7114ZI –00–GT3
 Y = Production Year (Last Digit)
 M = Production Month
 (1–9, A, B, C or O, N, D)
 P = Product Revision

Y = Production Year (Last Digit)
 M = Production Month
 (1–9, A, B, C or O, N, D)
 B = Product Revision (Fixed as “B”)
 R = Resistance:
 2 = 10 kΩ
 4 = 50 kΩ
 5 = 100 kΩ
 5114G = Device Code
 I = Temperature Range (Industrial)

TDFN

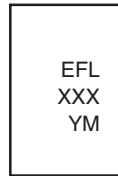

EF = DP7114VP2I-10-GT3
 HF = DP7114VP2I-50-GT3
 GW = DP7114VP2I-00-GT3
 L = Assembly Location
 XXX = Last Three Digits of Assembly Lot Number
 Y = Production Year (Last Digit)
 M = Production Month (1–9, A, B, C or O, N, D)

Functional Diagram

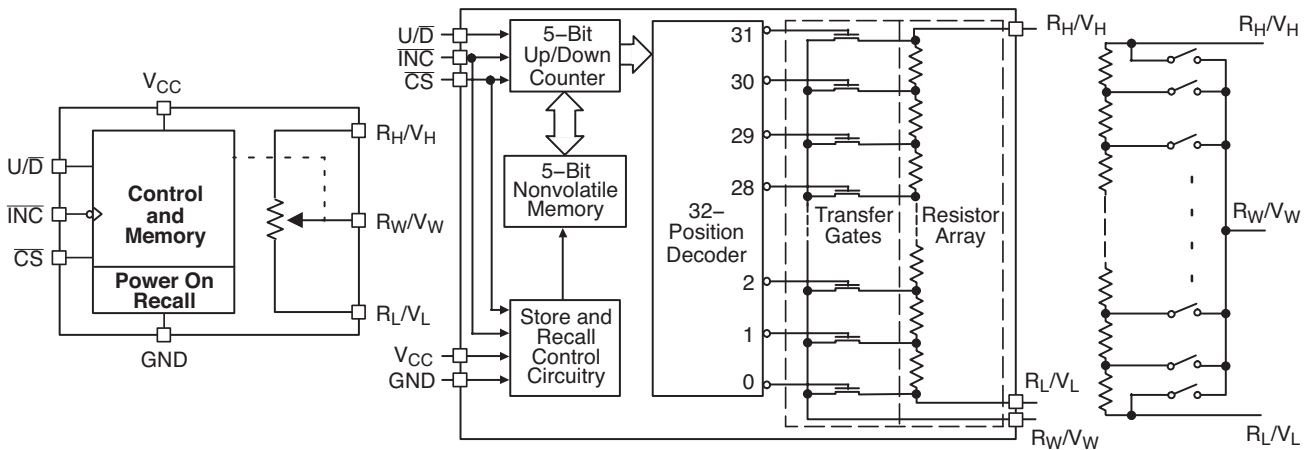

Figure 1. General

Figure 2. Detailed

Figure 3. Electronic Potentiometer Implementation

DP7114

Table 1. PIN DESCRIPTIONS

Name	Function
$\overline{\text{INC}}$	Increment Control
$\text{U}/\overline{\text{D}}$	Up/Down Control
R_H	Potentiometer High Terminal
GND	Ground
R_W	Wiper Terminal
R_L	Potentiometer Low Terminal
$\overline{\text{CS}}$	Chip Select
V_{CC}	Supply Voltage

Pin Function

$\overline{\text{INC}}$: Increment Control Input

The $\overline{\text{INC}}$ input moves the wiper in the up or down direction determined by the condition of the $\text{U}/\overline{\text{D}}$ input.

$\text{U}/\overline{\text{D}}$: Up/Down Control Input

The $\text{U}/\overline{\text{D}}$ input controls the direction of the wiper movement. When in a high state and $\overline{\text{CS}}$ is low, any high-to-low transition on $\overline{\text{INC}}$ will cause the wiper to move one increment toward the R_H terminal. When in a low state and $\overline{\text{CS}}$ is low, any high-to-low transition on $\overline{\text{INC}}$ will cause the wiper to move one increment towards the R_L terminal.

R_H : High End Potentiometer Terminal

R_H is the high end terminal of the potentiometer. It is not required that this terminal be connected to a potential greater than the R_L terminal. Voltage applied to the R_H terminal cannot exceed the supply voltage, V_{CC} or go below ground, GND.

R_W : Wiper Potentiometer Terminal

R_W is the wiper terminal of the potentiometer. Its position on the resistor array is controlled by the control inputs, $\overline{\text{INC}}$, $\text{U}/\overline{\text{D}}$ and $\overline{\text{CS}}$. Voltage applied to the R_W terminal cannot exceed the supply voltage, V_{CC} or go below ground, GND.

R_L : Low End Potentiometer Terminal

R_L is the low end terminal of the potentiometer. It is not required that this terminal be connected to a potential less

than the R_H terminal. Voltage applied to the R_L terminal cannot exceed the supply voltage, V_{CC} or go below ground, GND. R_L and R_H are electrically interchangeable.

$\overline{\text{CS}}$: Chip Select

The chip select input is used to activate the control input of the DP7114 and is active low. When in a high state, activity on the $\overline{\text{INC}}$ and $\text{U}/\overline{\text{D}}$ inputs will not affect or change the position of the wiper.

Device Operation

The DP7114 operates like a digital potentiometer with R_H and R_L equivalent to the high and low terminals and R_W equivalent to the mechanical potentiometer's wiper. There are 32 available tap positions including the resistor end points, R_H and R_L . There are 31 resistor elements connected in series between the R_H and R_L terminals. The wiper terminal is connected to one of the 32 taps and controlled by three inputs, $\overline{\text{INC}}$, $\text{U}/\overline{\text{D}}$ and $\overline{\text{CS}}$. These inputs control a five-bit up/down counter whose output is decoded to select the wiper position. The selected wiper position can be stored in nonvolatile memory using the $\overline{\text{INC}}$ and $\overline{\text{CS}}$ inputs.

With $\overline{\text{CS}}$ set LOW the DP7114 is selected and will respond to the $\text{U}/\overline{\text{D}}$ and $\overline{\text{INC}}$ inputs. HIGH to LOW transitions on $\overline{\text{INC}}$ will increment or decrement the wiper (depending on the state of the $\text{U}/\overline{\text{D}}$ input and five-bit counter). The wiper, when at either fixed terminal, acts like its mechanical equivalent and does not move beyond the last position. The value of the counter is stored in nonvolatile memory whenever $\overline{\text{CS}}$ transitions HIGH while the $\overline{\text{INC}}$ input is also HIGH. When the DP7114 is powered-down, the last stored wiper counter position is maintained in the nonvolatile memory. When power is restored, the contents of the memory are recalled and the counter is set to the value stored.

With $\overline{\text{INC}}$ set low, the DP7114 may be de-selected and powered down without storing the current wiper position in nonvolatile memory. This allows the system to always power up to a preset value stored in nonvolatile memory.

DP7114

Table 2. OPERATION MODES

INC	CS	U/D	Operation
High to Low	Low	High	Wiper toward H
High to Low	Low	Low	Wiper toward L
High	Low to High	X	Store Wiper Position
Low	Low to High	X	No Store, Return to Standby
X	High	X	Standby

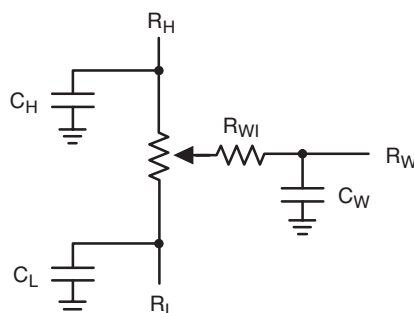

Figure 4. Potentiometer Equivalent Circuit

Table 3. ABSOLUTE MAXIMUM RATINGS

Parameters	Ratings	Units
Supply Voltage V_{CC} to GND	-0.5 to +7	V
Inputs \overline{CS} to GND	-0.5 to $V_{CC} + 0.5$	V
\overline{INC} to GND	-0.5 to $V_{CC} + 0.5$	V
$\overline{U/D}$ to GND	-0.5 to $V_{CC} + 0.5$	V
R_H to GND	-0.5 to $V_{CC} + 0.5$	V
R_L to GND	-0.5 to $V_{CC} + 0.5$	V
R_W to GND	-0.5 to $V_{CC} + 0.5$	V
Operating Ambient Temperature Industrial ('I' suffix)	-40 to +85	°C
Junction Temperature	+150	°C
Storage Temperature	-65 to 150	°C
Lead Soldering (10 s max)	+300	°C

Stresses exceeding Maximum Ratings may damage the device. Maximum Ratings are stress ratings only. Functional operation above the Recommended Operating Conditions is not implied. Extended exposure to stresses above the Recommended Operating Conditions may affect device reliability.

Table 4. RELIABILITY CHARACTERISTICS

Symbol	Parameter	Test Method	Min	Typ	Max	Units
V_{ZAP} (Note 1)	ESD Susceptibility	MIL-STD-883, Test Method 3015	2000			V
I_{LTH} (Notes 1, 2)	Latch-Up	JEDEC Standard 17	100			mA
T_{DR}	Data Retention	MIL-STD-883, Test Method 1008	100			Years
N_{END}	Endurance	MIL-STD-883, Test Method 1003	1,000,000			Stores

1. This parameter is tested initially and after a design or process change that affects the parameter.
2. Latch-up protection is provided for stresses up to 100 mA on address and data pins from -1 V to $V_{CC} + 1$ V.

DP7114

Table 5. DC ELECTRICAL CHARACTERISTICS ($V_{CC} = +2.5\text{ V}$ to $+6\text{ V}$ unless otherwise specified)

Symbol	Parameter	Conditions	Min	Typ	Max	Units
POWER SUPPLY						
V_{CC}	Operating Voltage Range		2.5	–	6.0	V
I_{CC1}	Supply Current (Increment)	$V_{CC} = 6\text{ V}$, $f = 1\text{ MHz}$, $I_W = 0$	–	–	100	μA
		$V_{CC} = 6\text{ V}$, $f = 250\text{ kHz}$, $I_W = 0$	–	–	50	μA
I_{CC2}	Supply Current (Write)	Programming, $V_{CC} = 6\text{ V}$	–	–	1000	μA
		$V_{CC} = 3\text{ V}$	–	–	500	μA
I_{SB1} (Note 4)	Supply Current (Standby)	$\overline{CS} = V_{CC} - 0.3\text{ V}$ U/\overline{D} , $\overline{INC} = V_{CC} - 0.3\text{ V}$ or GND	–	–	1	μA
LOGIC INPUTS						
I_{IH}	Input Leakage Current	$V_{IN} = V_{CC}$	–	–	10	μA
I_{IL}	Input Leakage Current	$V_{IN} = 0\text{ V}$	–	–	–10	μA
V_{IH2}	CMOS High Level Input Voltage	$2.5\text{ V} \leq V_{CC} \leq 6\text{ V}$	$V_{CC} \times 0.7$	–	$V_{CC} + 0.3$	V
V_{IL2}	CMOS Low Level Input Voltage		–0.3	–	$V_{CC} \times 0.2$	V
POTENTIOMETER CHARACTERISTICS						
R_{POT}	Potentiometer Resistance	–10 Device		10		k Ω
		–50 Device		50		
		–00 Device		100		
R_{TOL}	Pot. Resistance Tolerance				± 20	%
V_{RH}	Voltage on R_H pin		0		V_{CC}	V
V_{RL}	Voltage on R_L pin		0		V_{CC}	V
RES	Resolution			3.2		%
INL	Integral Linearity Error	$I_W \leq 2\ \mu\text{A}$		0.5	1	LSB
DNL	Differential Linearity Error	$I_W \leq 2\ \mu\text{A}$		0.25	0.5	LSB
R_{WI}	Wiper Resistance	$V_{CC} = 5\text{ V}$, $I_W = 1\text{ mA}$		70	200	Ω
		$V_{CC} = 2.5\text{ V}$, $I_W = 1\text{ mA}$		150	400	Ω
I_W	Wiper Current		–4.4		4.4	mA
$TC_{R_{POT}}$	TC of Pot Resistance			300		ppm/ $^{\circ}\text{C}$
TC_{RATIO}	Ratiometric TC				20	ppm/ $^{\circ}\text{C}$
V_N	Noise	100 kHz / 1 kHz		8/24		nV/ $\sqrt{\text{Hz}}$
$C_H/C_L/C_W$	Potentiometer Capacitances			8/8/25		pF
fc	Frequency Response	Passive Attenuator, 10 k Ω		1.7		MHz

3. This parameter is tested initially and after a design or process change that affects the parameter.
4. Latch-up protection is provided for stresses up to 100 mA on address and data pins from -1 V to $V_{CC} + 1\text{ V}$.
5. I_W = source or sink.
6. These parameters are periodically sampled and are not 100% tested.

DP7114

Table 6. AC TEST CONDITIONS

V _{CC} Range	2.5 V ≤ V _{CC} ≤ 6 V
Input Pulse Levels	0.2 x V _{CC} to 0.7 x V _{CC}
Input Rise and Fall Times	10 ns
Input Reference Levels	0.5 x V _{CC}

Table 7. AC OPERATING CHARACTERISTICS (V_{CC} = +2.5 V to +6.0 V, V_H = V_{CC}, V_L = 0 V, unless otherwise specified)

Symbol	Parameter	Min	Typ (Note 7)	Max	Units
t _{CI}	\overline{CS} to \overline{INC} Setup	100	–	–	ns
t _{DI}	U/ \overline{D} to \overline{INC} Setup	50	–	–	ns
t _{ID}	U/ \overline{D} to \overline{INC} Hold	100	–	–	ns
t _{IL}	\overline{INC} LOW Period	250	–	–	ns
t _{IH}	\overline{INC} HIGH Period	250	–	–	ns
t _{IC}	\overline{INC} Inactive to \overline{CS} Inactive	1	–	–	μs
t _{CPH}	\overline{CS} Deselect Time (NO STORE)	100	–	–	ns
t _{CPH}	\overline{CS} Deselect Time (STORE)	10	–	–	ms
t _{IW}	\overline{INC} to V _{OUT} Change	–	1	5	μs
t _{CYC}	\overline{INC} Cycle Time	1	–	–	μs
t _R , t _F (Note 8)	\overline{INC} Input Rise and Fall Time	–	–	500	μs
t _{PU} (Note 8)	Power-up to Wiper Stable	–	–	1	ms
t _{WR}	Store Cycle	–	5	10	ms

7. Typical values are for T_A = 25°C and nominal supply voltage.

8. This parameter is periodically sampled and not 100% tested.

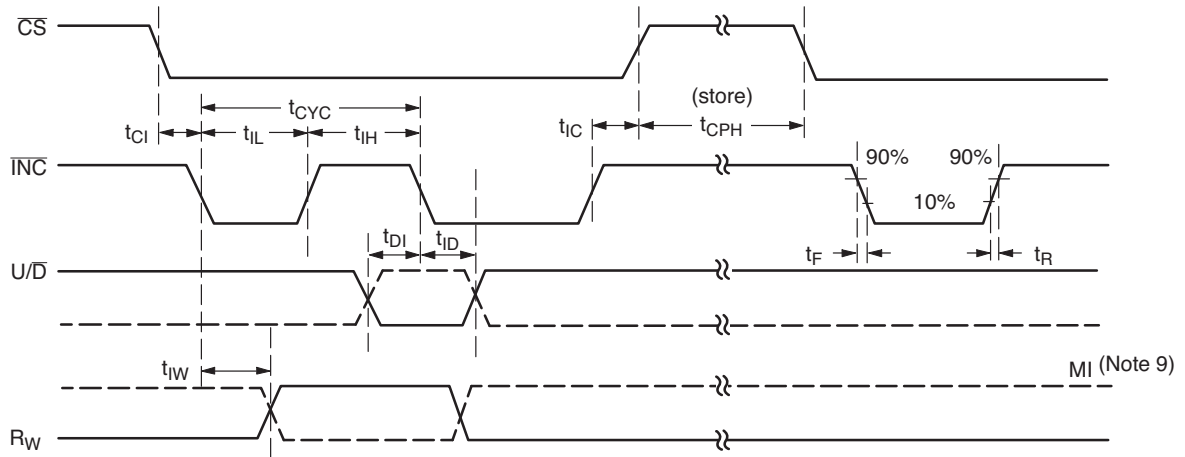

Figure 5. A.C. Timing

9. MI in the A.C. Timing diagram refers to the minimum incremental change in the W output due to a change in the wiper position.

DP7114

Applications Information

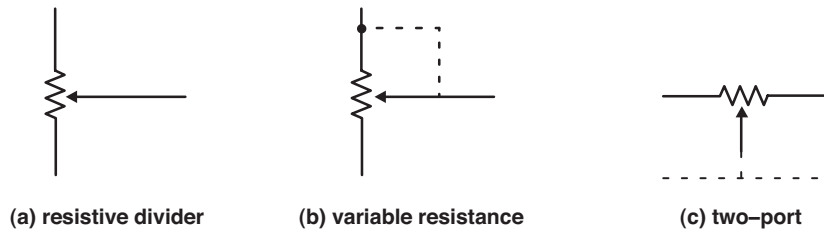

Figure 6. Potentiometer Configuration

Applications

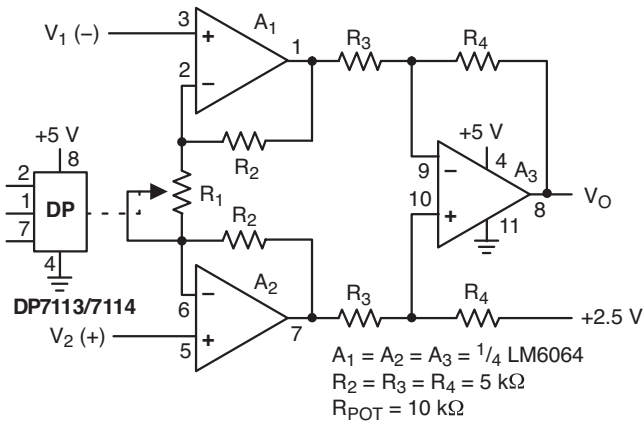

Figure 7. Programmable Instrumentation Amplifier

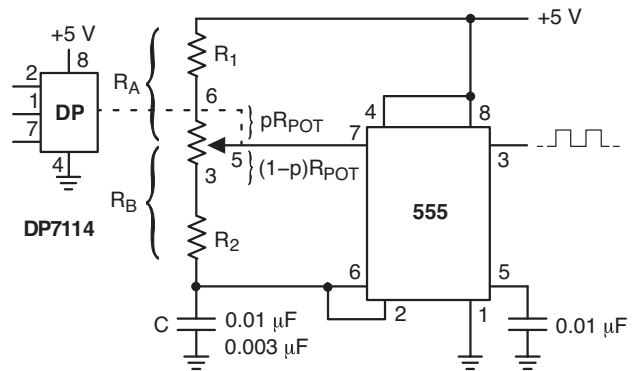

Figure 8. Programmable Sq. Wave Oscillator (555)

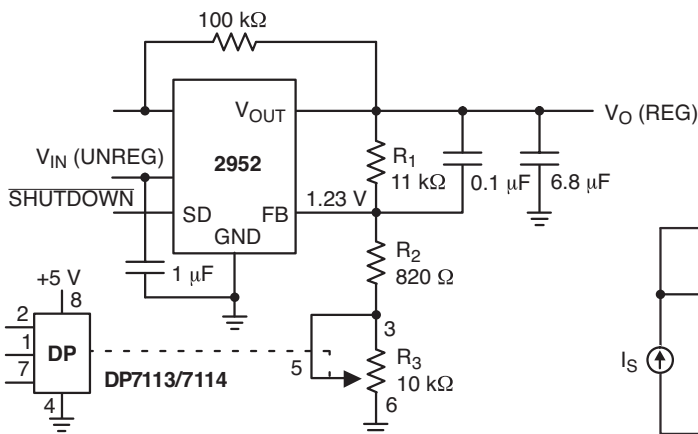

Figure 9. Programmable Voltage Regulator

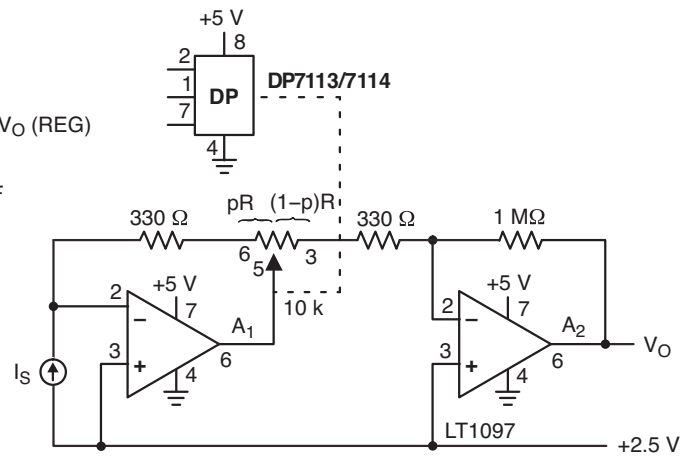

Figure 10. Programmable I to V Convertor

DP7114

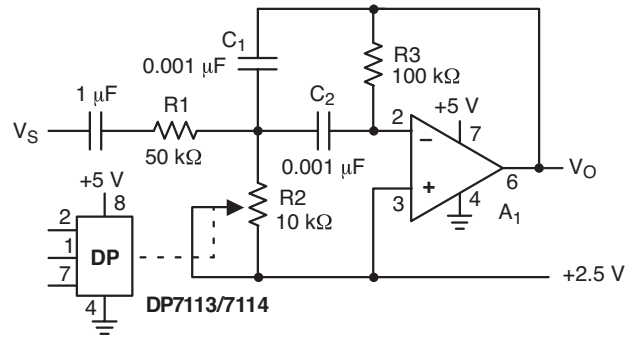

Figure 11. Programmable Bandpass Filter

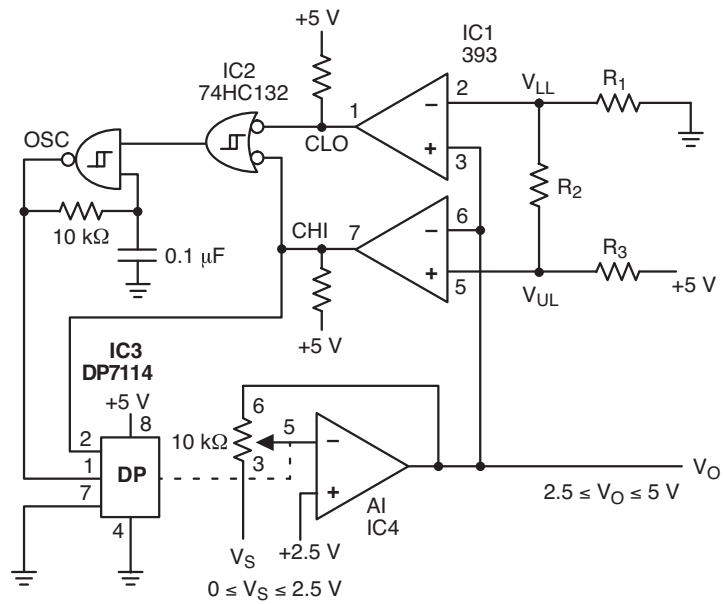
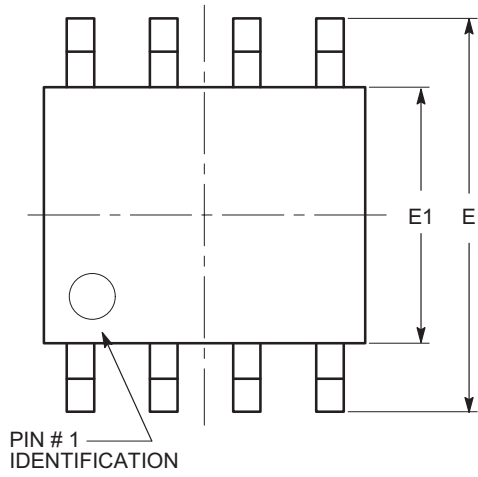

Figure 12. Automatic Gain Control

DP7114

PACKAGE DIMENSIONS

SOIC 8, 150 mils



TOP VIEW

SYMBOL	MIN	NOM	MAX
A	1.35		1.75
A1	0.10		0.25
b	0.33		0.51
c	0.19		0.25
D	4.80		5.00
E	5.80		6.20
E1	3.80		4.00
e	1.27 BSC		
h	0.25		0.50
L	0.40		1.27
θ	0°		8°

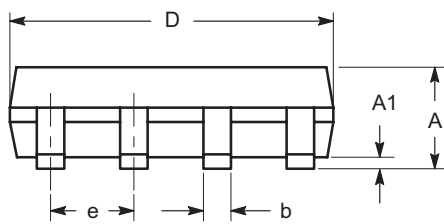

SIDE VIEW

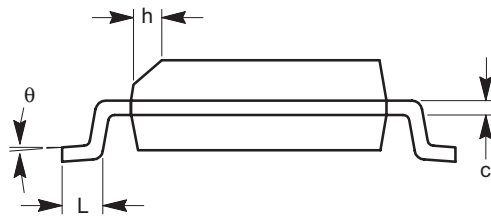

END VIEW

Notes:

- (1) All dimensions are in millimeters. Angles in degrees.
- (2) Complies with JEDEC MS-012.

DP7114

PACKAGE DIMENSIONS

TSSOP8, 4.4x3

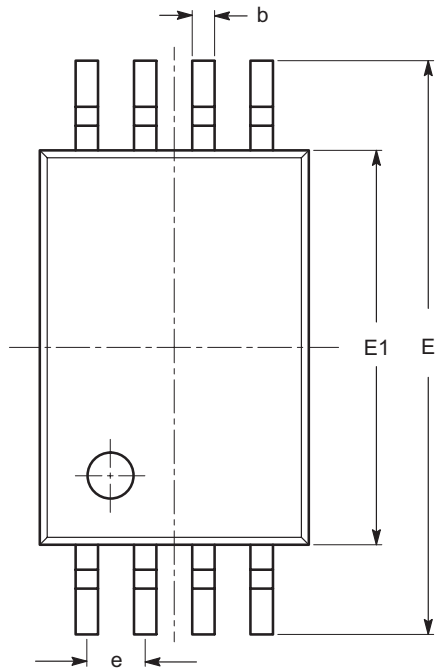

SYMBOL	MIN	NOM	MAX
A			1.20
A1	0.05		0.15
A2	0.80	0.90	1.05
b	0.19		0.30
c	0.09		0.20
D	2.90	3.00	3.10
E	6.30	6.40	6.50
E1	4.30	4.40	4.50
e	0.65 BSC		
L	1.00 REF		
L1	0.50	0.60	0.75
θ	0°		8°

TOP VIEW

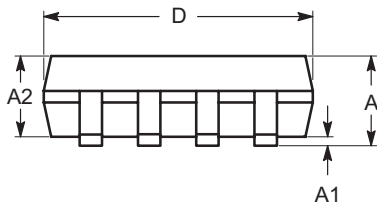

SIDE VIEW

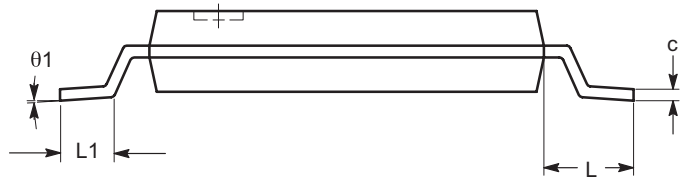

END VIEW

Notes:

- (1) All dimensions are in millimeters. Angles in degrees.
- (2) Complies with JEDEC MO-153.

DP7114

PACKAGE DIMENSIONS

MSOP 8, 3x3

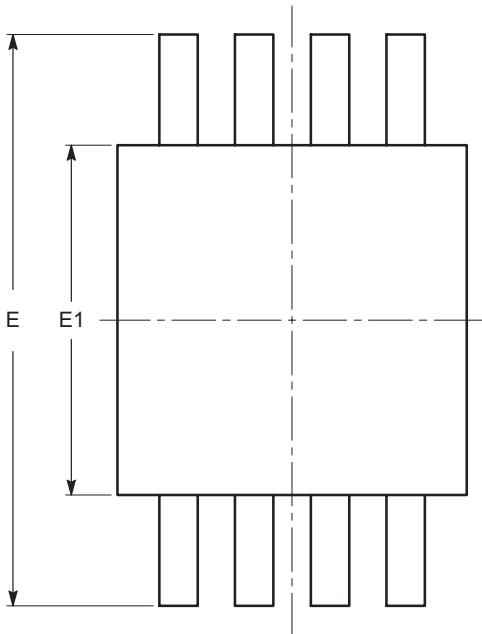

TOP VIEW

SYMBOL	MIN	NOM	MAX
A			1.10
A1	0.05	0.10	0.15
A2	0.75	0.85	0.95
b	0.22		0.38
c	0.13		0.23
D	2.90	3.00	3.10
E	4.80	4.90	5.00
E1	2.90	3.00	3.10
e	0.65 BSC		
L	0.40	0.60	0.80
L1	0.95 REF		
L2	0.25 BSC		
θ	0°		6°

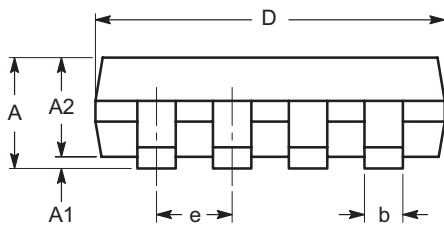

SIDE VIEW

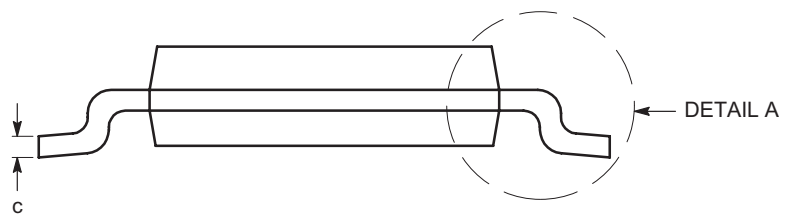

END VIEW

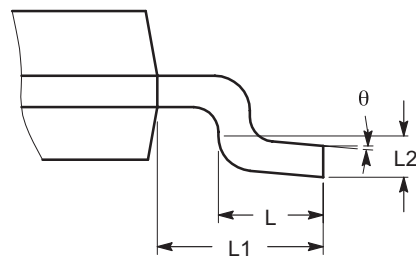

DETAIL A

Notes:

- (1) All dimensions are in millimeters. Angles in degrees.
- (2) Complies with JEDEC MO-187.

DP7114

PACKAGE DIMENSIONS

TDFN8, 2x3

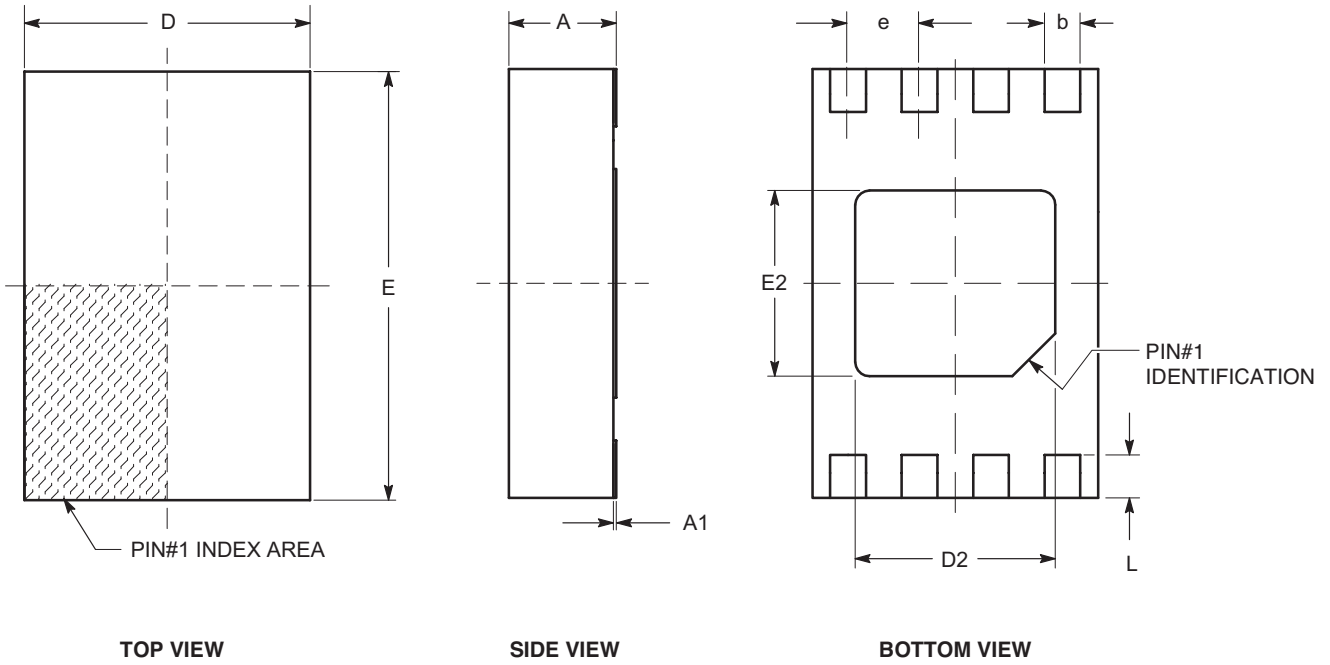

SYMBOL	MIN	NOM	MAX
A	0.70	0.75	0.80
A1	0.00	0.02	0.05
A2	0.45	0.55	0.65
A3	0.20 REF		
b	0.20	0.25	0.30
D	1.90	2.00	2.10
D2	1.30	1.40	1.50
E	2.90	3.00	3.10
E2	1.20	1.30	1.40
e	0.50 TYP		
L	0.20	0.30	0.40

Notes:

- (1) All dimensions are in millimeters.
- (2) Complies with JEDEC MO-229.

DP7114

Table 8. ORDERING INFORMATION

Orderable Part Numbers	Reset Threshold Voltage	Package–Pin	Lead Finish
DP7114VI–10–GT3	10	SOIC–8	NiPdAu
DP7114VI–50–GT3	50		
DP7114VI–00–GT3	100		
DP7114VP2I–10–GT3 (Note 10)	10	TDFN–8 2 x 3 mm	NiPdAu
DP7114VP2I–50–GT3 (Note 10)	50		
DP7114VP2I–00–GT3 (Note 10)	100		
DP7114YI–10–GT3	10	TSSOP–8	NiPdAu
DP7114YI–50–G	50		
DP7114YI–00–GT3	100		
DP7114ZI–10–GT3	10	MSOP–8	NiPdAu
DP7114ZI–50–GT3	50		
DP7114ZI–00–GT3	100		

10. Contact factory for package availability.

DP7114

Example of Ordering Information (Note 14)

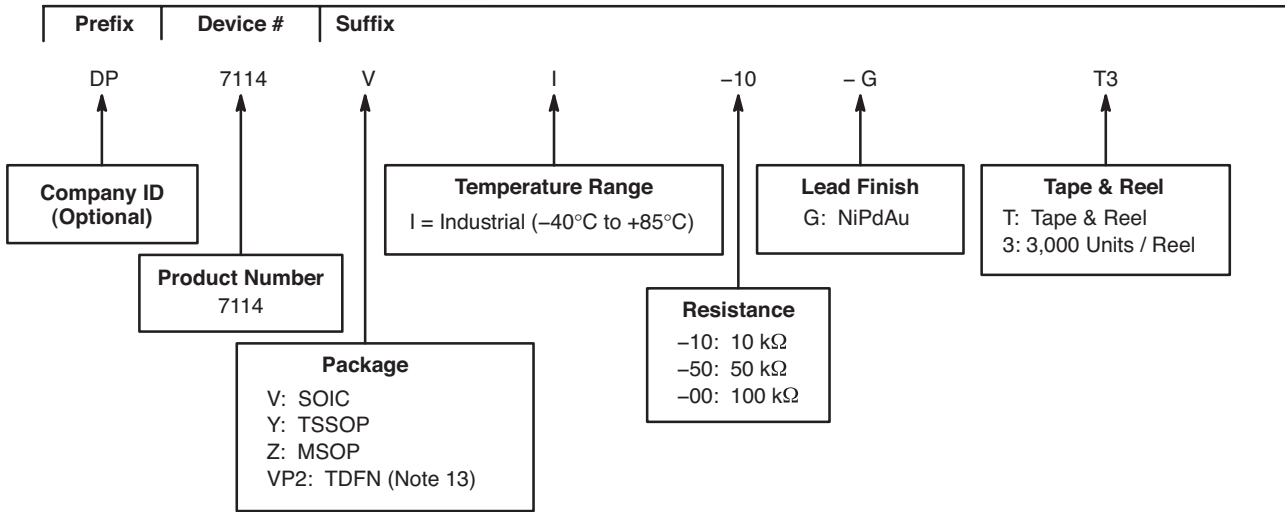

11. All packages are RoHS-compliant (Lead-free, Halogen-free).
12. The standard lead finish is NiPdAu.
13. Contact factory for package availability.
14. The device used in the above example is a DP7114VI-10-GT3 (SOIC, Industrial Temperature, 10 kΩ, NiPdAu, Tape & Reel, 3,000/Reel).

NIDEC COPAL reserves the right to make changes without further notice to any products herein.

NIDEC COPAL makes no warranty, representation or guarantee regarding the suitability of its products for any particular purpose, nor does NIDEC COPAL assume any liability arising out of the application or use of any product or circuit, and specifically disclaims any and all liability, including without limitation special, consequential or incidental damages.

"Typical" parameters which may be provided in NIDEC COPAL data sheets and/or specifications can and do vary in different applications and actual performance may vary over time. All operating parameters, including "Typicals" must be validated for each customer application by customer's technical experts.

NIDEC COPAL does not convey any license under its patent rights nor the rights of others.

NIDEC COPAL products are not designed, intended, or authorized for use as components in systems intended for surgical implant into the body, or other applications intended to support or sustain life, or for any other application in which the failure of the NIDEC COPAL product could create a situation where personal injury or death may occur.

Should Buyer purchase or use NIDEC COPAL products for any such unintended or unauthorized application, Buyer shall indemnify and hold NIDEC COPAL and its officers, employees, subsidiaries, affiliates, and distributors harmless against all claims, costs, damages, and expenses, and reasonable attorney fees arising out of, directly or indirectly, any claim of personal injury or death associated with such unintended or unauthorized use, even if such claim alleges that NIDEC COPAL was negligent regarding the design or manufacture of the part.