

NOTE: UNLESS OTHERWISE SPECIFIED.

1. DIMENSIONS SHALL BE INTERPRETED PER ANSI Y14.5M-1994.
 2. SPEC. ARE SHOWN ON DRAWING "307-0100-322".
 3. MATERIAL ARE SHOWN ON DRAWING "307-0100-324".
- △ PRODUCT No. MATRIX :

H M 35 ** * -***

MODIFICATION CODE
(SEE DWG. "307-0000-375")
PLATING CODE
(SEE DWG. "307-0100-324")
No. OF SINGLE ROW POS.

5. PLEASE CONTACT FOXCONN SALES REPRESENTATIVE TO VERIFY PRODUCT DETAILS&AVAILABILITY.
6. HARMFUL MATERIAL CONTROL PLEASE FOLLOW FOXCONN'S DOC. "EPI12".

REV.	ECN No.	APPD.
A	IC023412	Yhsin Chen 12/9/05
B	HC048369	Ady Zhou 5/17/02
C	HC051098	Ady Zhou 9/28/04
D	HC053753	Ady Zhou 2/22/05

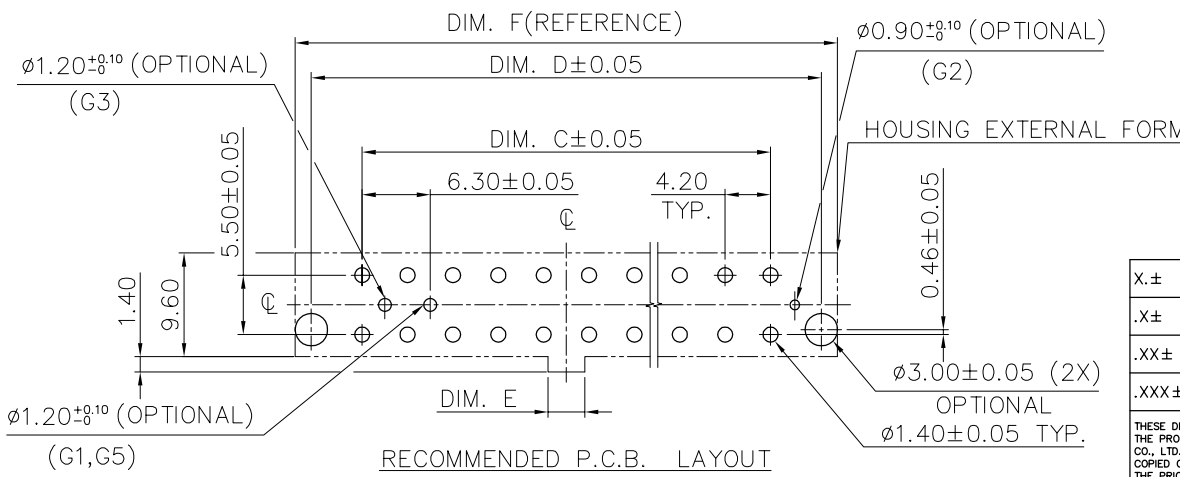
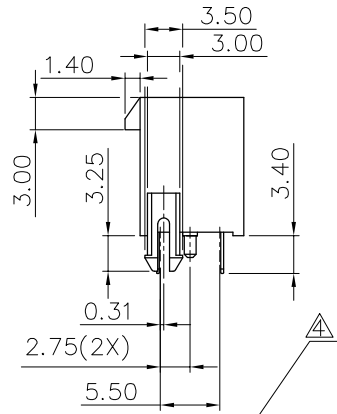
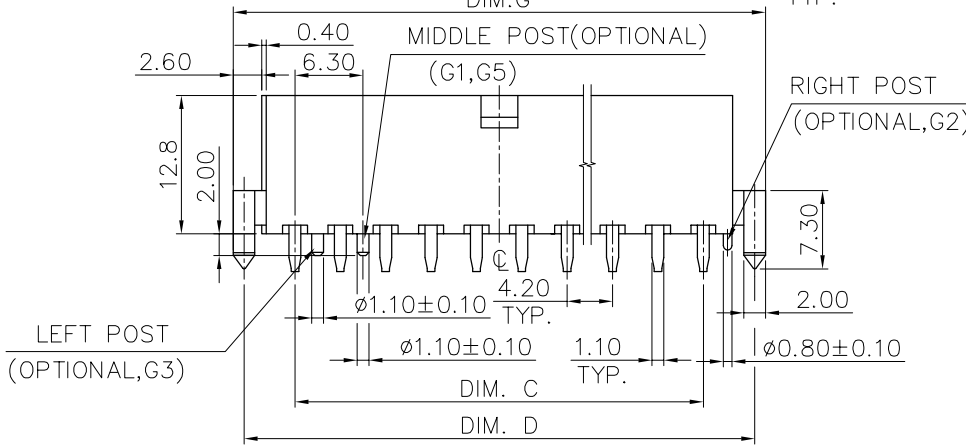
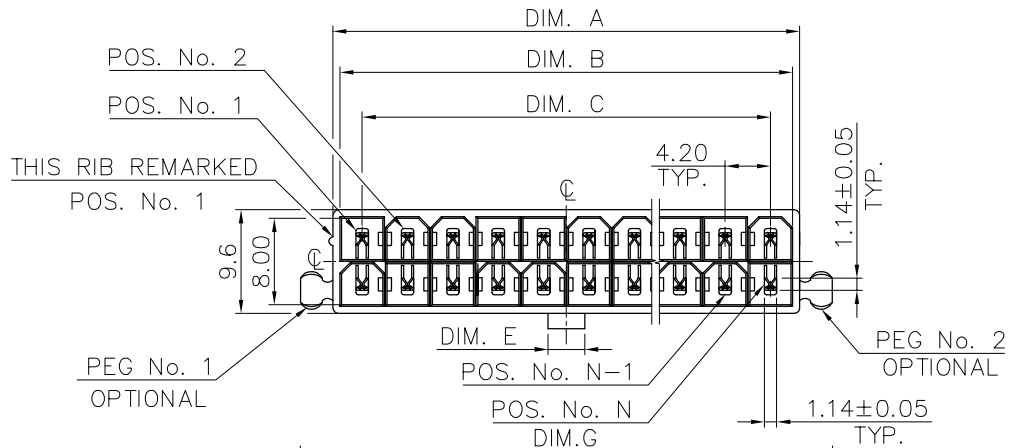

HM3512*-***	12/24	51.60	50.00	46.20	55.60	57.60	57.60
HM3511*-***	11/22	47.40	45.80	42.00	51.40	53.40	53.40
HM3510*-***	10/20	43.20	41.60	37.80	47.20	49.20	49.20
HM3509*-***	9/18	39.00	37.40	33.60	43.00	45.00	45.00
HM3508*-***	8/16	34.80	33.20	29.40	38.80	40.80	40.80
HM3507*-***	7/14	30.60	29.00	25.20	34.60	36.60	36.60
HM3506*-***	6/12	26.40	24.80	21.00	30.40	32.40	32.40
HM3505*-***	5/10	22.20	20.60	16.80	26.20	28.20	28.20
HM3504*-***	4/8	18.00	16.40	12.60	22.00	24.00	24.00
HM3503*-***	3/6	13.80	12.20	8.40	17.80	19.80	19.80
HM3502*-***	2/4	9.60	8.00	4.20	13.60	15.60	15.60
PART No.	No. OF POS.	DIM. A	DIM. B	DIM. C	DIM. D	DIM. F	DIM. G

X.±	X'.±	UNITS	NAME(INTENDED USE)	FOXCONN
.X± 0.38	.X'±	mm	POWER CONN.	HON HAI PRECISION IND. CO.,LTD. TAIPEI, TAIWAN, R.O.C.
.XX± 0.25	.XX'±	MAT'L	PART No.(INTENDED USE)	TITLE: CUSTOMER DRAWING
.XXX±	.XXX'±		HM35 SERIES	PLUG,SHROUDED,VERTICAL,T/H
THESE DRAWINGS AND SPECIFICATIONS ARE THE PROPERTY OF HON HAI PRECISION IND. CO., LTD. AND SHALL NOT BE REPRODUCED, COPIED OR USED IN ANY MANNER WITHOUT THE PRIOR WRITTEN CONSENT OF HON HAI PRECISION IND. CO., LTD.			APPD: Yhsin Chen	DWG No.: 307-0100-319
			Q'TY	CHKD: Wolfe Liu
				DR: Betty Xie7/15/09
				SCALE SHEET REV. N/A 1/2 DX7

REV.	ECN No.	APPD.

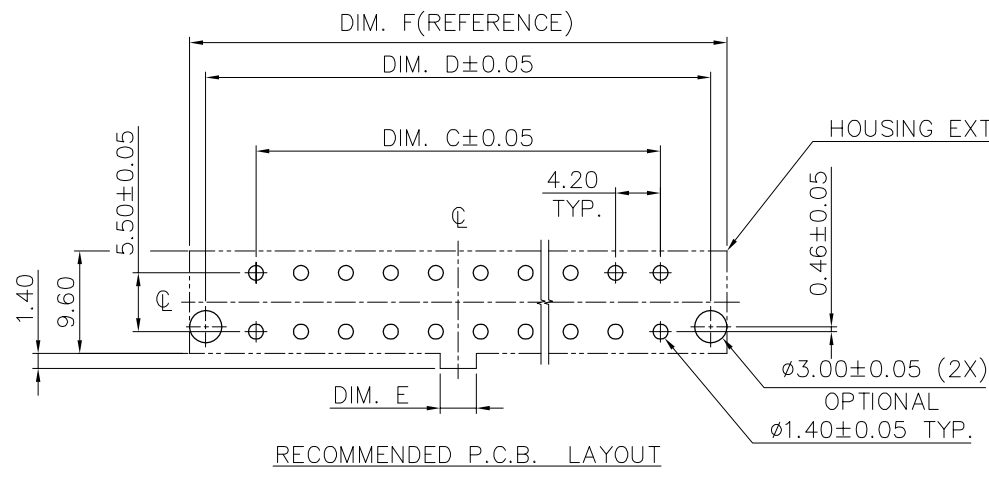
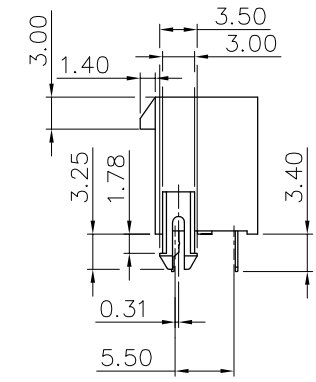
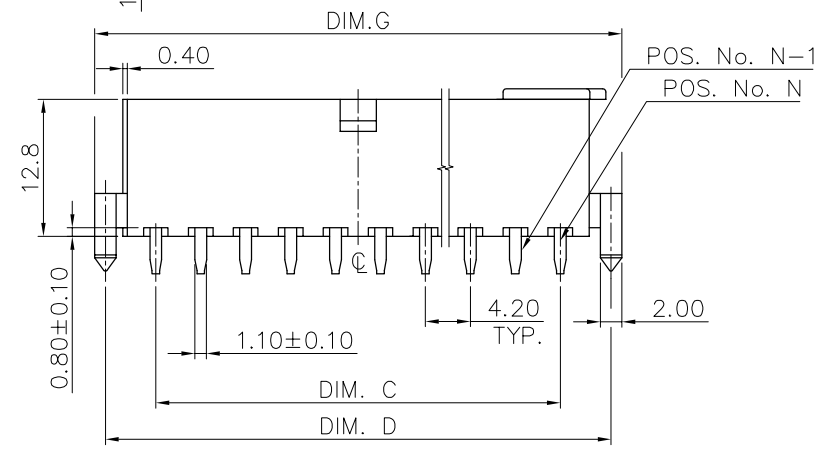
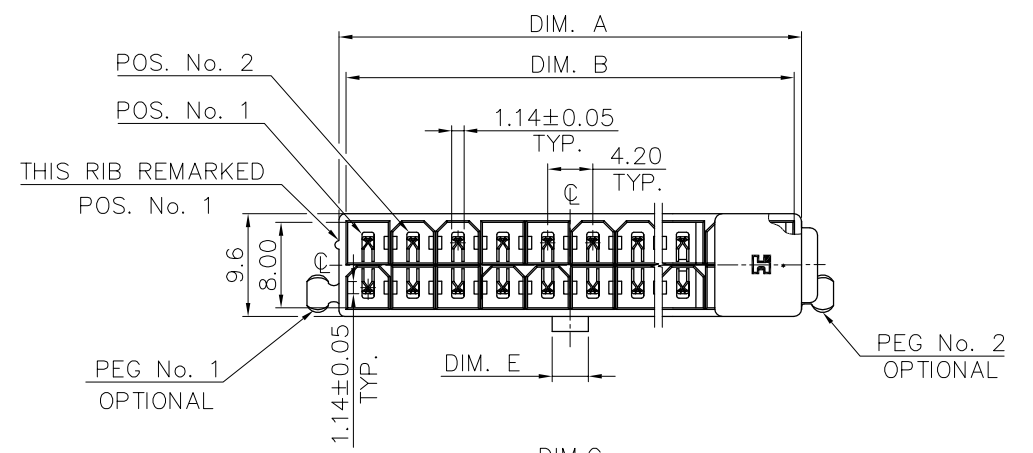

HOUSING EXTERNAL FORM

HM3512*-***	12/24	51.6	50.00	46.20	55.6	57.6	57.6
PART No.	No. OF POS.	DIM. A	DIM. B	DIM. C	DIM. D	DIM. F	DIM. G

X.±	X.±	UNITS	mm	NAME(INTENDED USE)	FOXCONN HON HAI PRECISION IND. CO.,LTD. TAIPEI, TAIWAN, R.O.C.
.X± 0.38	.X±	MAT'L		POWER CONN.	
.XX± 0.25	.XX±			PART No.(INTENDED USE)	TITLE:
.XXX±	.XXX±	FINISH		HM35 SERIES	CUSTOMER DRAWING PLUG,SHROUDED,VERTICAL,T/H
THESE DRAWINGS AND SPECIFICATIONS ARE THE PROPERTY OF HON HAI PRECISION IND. CO., LTD. AND SHALL NOT BE REPRODUCED, COPIED OR USED IN ANY MANNER WITHOUT THE PRIOR WRITTEN CONSENT OF HON HAI PRECISION IND. CO., LTD.				APPD: Yihsin Chen	DWG No.:
				CHKD: Wolfe Liu	307-0100-319
				DR: Betty Xie7/15'09	SCALE SHEET REV.
					N/A 2/2 DX7

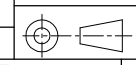

ITEM	DESC.	Q'TY	MATERIAL	TREATMENT	REMARK
1	HOUSING	1	PA6T UL94 V-0	COLOR IVORY	
2	CONTACT	SEE NOTES BELOW	BRASS	A) 50u" MIN. NICKEL UNDER PLATING. B) GOLD FLASH OR 100u" MIN. TIN PLATING OVER NICKEL.	
3	COVER	1	PBT, UL94 V-0	COLOR BLACK	ONLY FOR HM3512*-F**

NOTES :

1. HARMFUL MATERIAL CONTROL PLEASE FOLLOW FOXCONN'S DOC. "EPI12".

2. PRODUCT No. MATRIX:

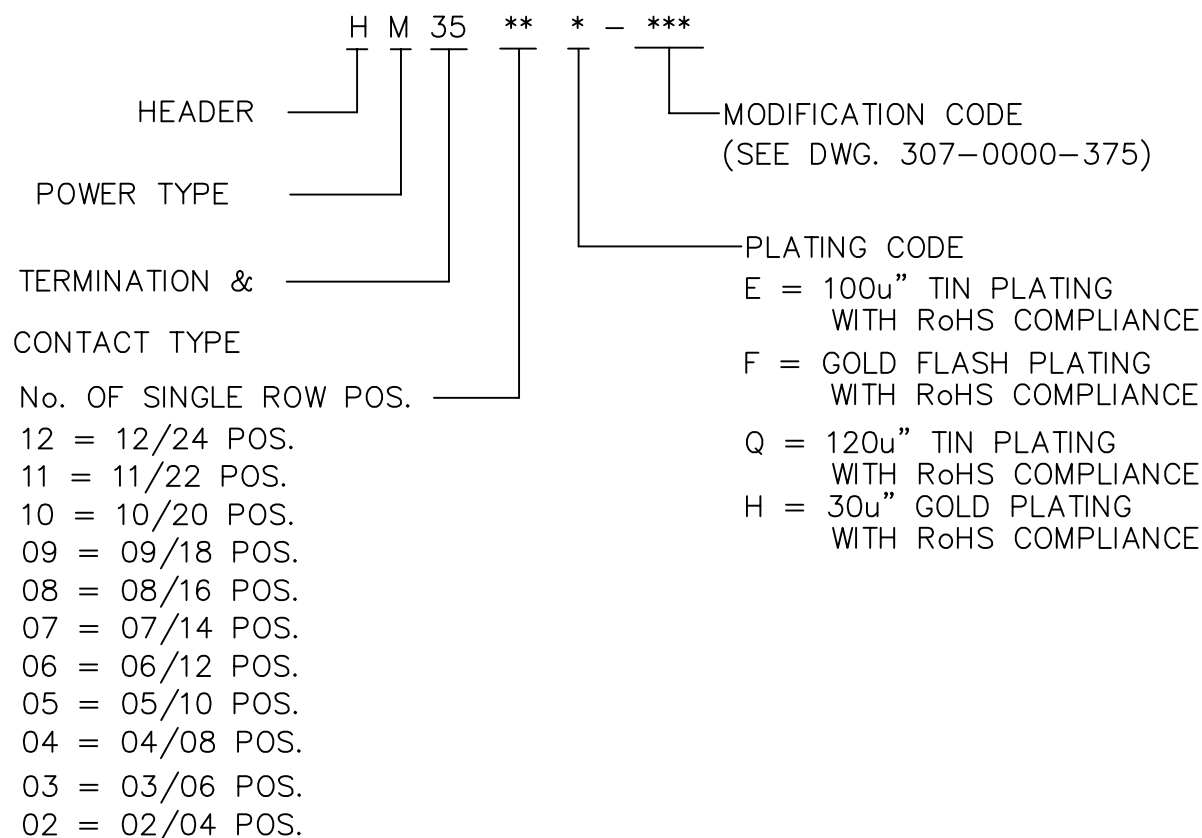

3. PLEASE CONTACT FOXCONN SALES REPRESENTATIVE TO VERIFY
PRODUCT DETAILS&AVAILABILITY.

E	BC077040388	Yusan
D	BC077011122	Yusan
C	BC06743773	Yusan 7/27'06
B	HC0513520	Ady Zhou 12/9'05
A	IC023412	Dick Lee 6/24'98
REV.	ECN No.	APPD.

FOXCONN HON HAI PRECISION IND. CO.,LTD. TAIPEI, TAIWAN, R.O.C.	
APPD. : Yihsin Chen	TITLE : MATERIAL LIST PLUG,VERTICAL,T/H
CHKD. : Wolfe Liu	PROD. SERIES : HM35 SERIES
DR. : Chuck Zhang	DWG. No. : 307-0100-324
12/24'10	REV. : EX2 SHEET : 1/1

REV.	ECN. NO.	APPD.
A	HC982447	Dick Lee 10.3'98
B	HC990023	Dick Lee 1/4'99
C	HC991494	Dick Lee 5/7'99
D	MC000668	Y.K.Liu 3/11/00
E	MC012543	Yihsin Chen 9/17'01
F	IC027608	Yihsin Chen 10/21,02
G	HC048095	Ady Zhou 9/6'04
H	HC0410461	Ady Zhou 11/20'04
J	HC057399	Yusang 7/27'05
K	BC077052105	Yusan
L	BC077082703	Yusan
M	BC087045287	Jake W.Yuan
N	BC087068504	Jake W.Yuan
P	BC097001984	Yusan
Q	BC097080070	Yusan

H M ** * * - (*) * * * *

SEE REMARK
 COLOR OPTIONAL
 NONE: NATURE COLOR
 B: BLACK COLOR
 A: COOL GRAY COLOR

INTERNAL CODE
 NONE=RoHS PROUDCT
 H=RoHS & HALOGEN FREE
 MATERIAL OPTIONAL
 NONE: HALOGEN MATERIAL
 L: HIGH TEMPERATURE
 HALOGEN FREE MATERIAL
 B: THERMOPLASTIC
 HALOGEN FREE MATERIAL

CODE	DESCRIPTION			
	PEG	PEG WIDTH	POST	PIN MISSING
NONE	NONE	N/A	NONE	FULL PIN
P1	PEG #1	3.50mm	NONE	FULL PIN
P2	PEG #1 & PEG #2	3.50mm	NONE	FULL PIN
P3	PEG #1 & PEG #2	3.15mm	NONE	FULL PIN
P4	PEG #1	3.15mm	NONE	FULL PIN
P5	PEG #1 & PEG #2	3.00mm	NONE	FULL PIN
P6	PEG #1	3.00mm	NONE	FULL PIN
P7	PEG #2	3.15mm	NONE	FULL PIN
S1	PEG #2	3.50mm	NONE	19th PIN OMITTED
S3	NONE	N/A	NONE	19th PIN OMITTED
S5	NONE	N/A	NONE	1st, 2nd&11th PINS OMITTED
S6	PEG #1 & PEG #2	3.50mm	NONE	1st, 2nd&11th PINS OMITTED
S7	PEG #2	3.50mm	NONE	FULL PIN
S8	NONE	N/A	NONE	20th PIN OMITTED
G1	NONE	N/A	MIDDLE POST	FULL PIN
G2	NONE	N/A	RIGHT POST	FULL PIN
G3	NONE	N/A	LEFT POST	FULL PIN

REMARK:

H : CONTACT CURRENT RATING,HIGH CURRENT RATING,DIM.E = 3.40
 E : WITH LATCH, DIM.E = DIM.C
 K : WITH LATCH, DIM.E = 7.60
 F : WITH LATCH, DIM.E = 24.30; HOUSING COVERED WITH CAP
 D : WITH LATCH,DIM.E=24.30,HOUSING COVERED WITHOUT CAP
 N : CHAMFER TYPE II
 T : HIGH CURRENT RATING,WITH LATCH, DIM.E = DIM.C
 J : HOUSING COERED WITH CAP, WITH LATCH, DIM.E = DIM.C
 NONE: STANDARD PRODUCT , DIM.E = 3.40
 PLEASE CONTACT FOXCONN SALES REPRESENTATIVE TO VERIFY PRODUCT DETAIL&AVAILABILITY.
 THE CONCENTRATIONS OF Br&Cl CAN SATISFY THE REQUIREMENTS OF
 HALOGEN-FREE IN FOXCONN'S DOC "EPI12".

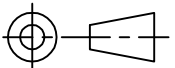
X.±	X°±	UNITS	NAME(INTENDED USE)	FOXCONN			
.X±	.X°±	MAT'L	POWER CONN.	HON HAI PRECISION IND. CO.,LTD. TAIPEI, TAIWAN, R.O.C.			
.XX±	.XX°±		PART NO.(INTENDED USE)	TITLE: CUSTOMER DRAWING			
.XXX±	.XXX°±	FINISH	HM SERIES	DWG NO.: 307-0000-375			
THESE DRAWINGS AND SPECIFICATIONS ARE THE PROPERTY OF HON HAI PRECISION IND. CO., LTD. AND SHALL NOT BE REPRODUCED, COPIED OR USED IN ANY MANNER WITHOUT THE PRIOR WRITTEN CONSENT OF HON HAI PRECISION IND. CO., LTD.			Q'TY	APPD: MAX S.H. YANG		SCALE	SHEET
			CHKD: Wolfe Liu	N/A		1/1	QX1
			DR: JustinFeng12/09'09				

PRODUCT SPECIFICATIONS :

1. MATERIAL AND FINISH :

- 1-1. HOUSING :
PA6T , UL94V-0 .
- 1-2. CONTACT :
BRASS
- 1-3. COVER (ONLY FOR HM3512*-F**) :
PBT, UL94V-0 , COLOR BLACK .

2. ELECTRICAL CHARACTERISTICS RATINGS :

- 2-1. CONTACT CURRENT RATING & APPLICABLE WIRES (UNIT: AMPS) .
THE SECOND TABLE ONLY FOR HIGH CURRENT RATING

Wire \ POS.	2&3	4-6	7-10	12-24
AWG#16	9	8	7	6
AWG#18	9	8	7	6
AWG#20	7	6	5	5
AWG#22	5	4	4	4
AWG#24	4	3	3	3
AWG#26	3	2	2	2
AWG#28	2	1	1	1

Wire \ POS.	2&3	4-6	7-10	12-24
AWG#16	12	11	10	9
AWG#18	12	11	10	9
AWG#20	9	9	8	8

- 2-2. DIELECTRIC WITHSTANDING VOLTAGE: 1500 VAC AT SEA LEVEL.
- 2-3. OPERATING VOLTAGE: 600V RMS.
- 2-4. INSULATION RESISTANCE: 1000 MEGOHMS MIN. .
- 2-5. LOW LEVEL CONTACT RESISTANCE : 30 MILLIOHMS MAX. INTIAL,
AFTER LIFE TEST 40 MILLIGOHMS MAX..

3. MECHANICAL CHARACTERISICS:

- 3-1. INSERTION FORCE: 0.70Kgf MAX. PER CONTACT.
- 3-2. WITHDRAWAL FORCE: 0.20Kgf MIN. PER CONTACT.
- 3-3. CONTACT RETENTION FORCE: 10N MIN. PER CONTACT.
- 3-4. DURABILITY: 50 CYCLES

4. ENVIRONMENTAL:

- 4-1. SOLDERABILITY: PASS MIL-STD-208F, METHOD 208.
- 4-2. OPERATING TEMPERATURE : -40°C TO +105°C.
- 4-3. HARMFUL MATERIAL CONTROL PLEASE FOLLOW FOXCONN'S
DOC. "EPI12".

5. PLEASE CONTACT FOXCONN SALES REPRESENTATIVE TO VERIFY PRODUCT DETAIL&AVAILABILITY.

E	BC097002522	Yusan
D	BC077048206	Yusan
C	HC067885	Yusan 6/29'06
B	HC0512836	Ady Zhou 12/9'05
A	IC023412	Yihsin Chen 5/17'05
REV.	ECN NO	APPD.

FOXCONN HON HAI PRECISION IND. CO.,LTD.
TAIPEI, TAIWAN, R.O.C.

APPD. : Yusan	TITLE : SPECIFICATION POWER HEADER, VERTICAL, T/H
CHKD. : Jake W.Yuan	PROD. SERIES : HM35 SERIES
DR. : Betty Xie 1/7'09	DWG. NO : 307-0100-322
	REV. : E SHEET : 1/1