

4

3

2

1

DO NOT SCALE DRAWING

THE INFORMATION CONTAINED HEREIN IS THE EXCLUSIVE PROPERTY OF VIRGINIA PANEL CORPORATION AND IS SUBMITTED FOR USE BY THE CUSTOMER ONLY. THE DATA SHALL NOT BE DUPLICATED, USED, OR DISCLOSED IN WHOLE OR IN PART FOR ANY PURPOSE OTHER THAN TO MAINTAIN THE EQUIPMENT PROVIDED. CONSULT WITH VIRGINIA PANEL CORPORATION ENGINEERING IF MORE DETAIL IS REQUIRED.

REVISIONS			
REV	DESCRIPTION	DATE	ENGR
A	ORIGINAL RELEASE ECN #06-310-0071	11/2/06	R HERRON

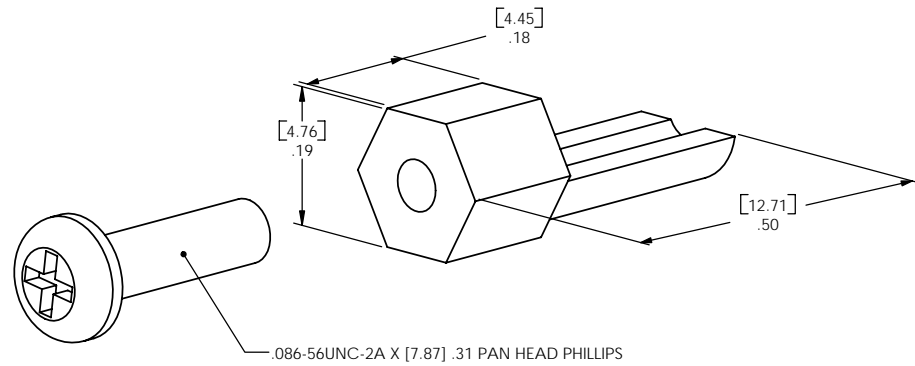

3. MATERIALS:  
 KEY: ALUMINUM ALLOY  
 HARDWARE: STAINLESS STEEL

2. PROVIDED IN 1 SET OF 2

1. FOR APPLICATION USE & CARE INFORMATION CONSULT VPC USERS GUIDE @WWW.VPC.COM

NOTES:

<b>CUSTOMER DRAWING</b>			
<b>VIRGINIA PANEL CORPORATION</b> WWW.VPC.COM			
<b>KEYING PIN KIT FOR RECEIVER AND ITA</b>			
DIMENSIONS ARE SHOWN AS:	SIZE	CAGE CODE	DWG. NO.
[MILLIMETERS]	C	18117	310113461
[INCHES]			
SCALE: 4:1	310113461	8/31/06	SHEET 1

4

3

2

1

D

C

B

A

D

C

B

A