

## DESCRIPTION

The EV6902-S-00B is an evaluation board for the MP6902DS. It is configured to provide synchronous rectification solution for Flyback/LLC topology.

MP6902DS features a synchronous gate output which enables high efficiency rectification by relating the schottky rectifier with a low Ron MOSFET.

## ELECTRICAL SPECIFICATIONS

Parameter	Symbol	Value	Units
Supply Voltage	V <sub>DD</sub>	8–24	V

## FEATURES

- Works with both Standard and Logic Level FETS
- Compatible with Energy Star, 1W Standby Requirements
- V<sub>DD</sub> Range From 8V to 24V
- Fast Turn-off Total Delay of 20ns
- Max 400kHz Switching Frequency
- <300µA Quiescent Current at Light Load Mode
- Supports CCM, DCM and Quasi-Resonant Topologies
- Supports High-side and Low-side Rectification
- Power Savings of Up to 1.5W in a Typical Notebook Adapter

## APPLICATIONS

- Industrial Power Systems
- Distributed Power Systems
- Battery Powered Systems
- Flyback/LLC Converters

All MPS parts are lead-free and adhere to the RoHS directive. For MPS green status, please visit MPS website under Quality Assurance. "MPS" and "The Future of Analog IC Technology" are Registered Trademarks of Monolithic Power Systems, Inc.

## EV6902DS-00A EVALUATION BOARD



(L x W x H) 1.14" x 1.14" x 0.6"  
2.9cm x 2.9cm x 1.4cm

Board Number	MPS IC Number
EV6902-S-00B	MP6902DS

## EVALUATION BOARD SCHEMATIC

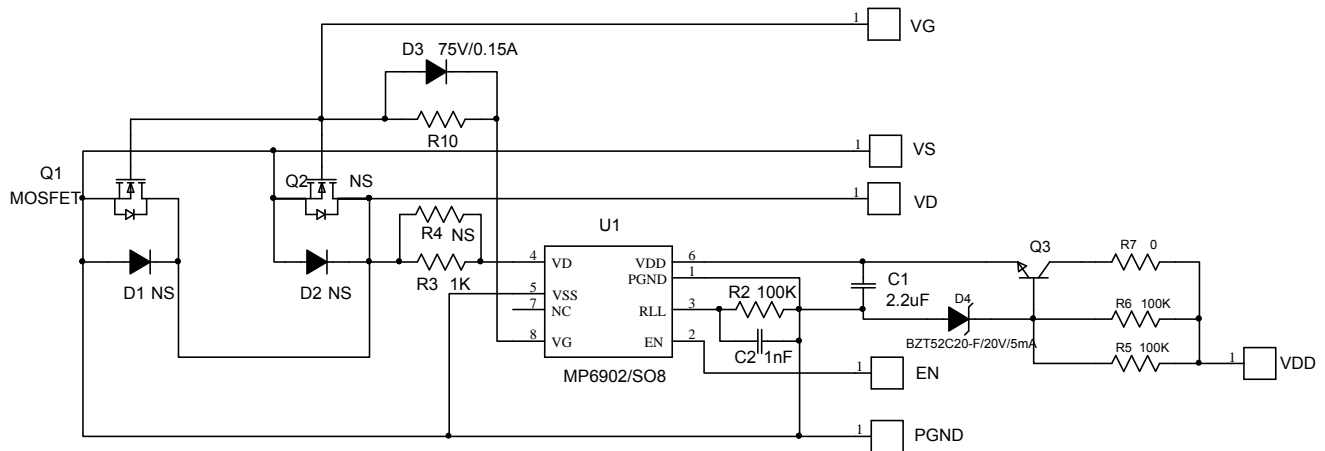

## EV6902-S-00B BILL OF MATERIALS

Qty	RefDes	Value	Description	Package	Manufacturer	Manufacturer P/N
1	C1	2.2 $\mu$ F	Ceramic Cap., 25V, X7R	0805	muRata	GRM21BR71E225KA73L
1	C2	1Nf	Ceramic Cap., 50V, X7R	0603	TDK	C1608X7R1H102K
2	R1,R7	0	Film Res., 5%	0603	Yageo	RC0603JR-070RL
1	R2	100k	Film Res., 1%	0603	Yageo	RC0603FR-07100KL
1	R3	1k	Film Res., 1%	0603	Royaohm	0603F1001T5E
0	R4	NS				
2	R5,R6	100k	Film Res., 5%	0805	Yageo	RC0805JR-07100KL
1	Q1	MOSFET	N-CH 100V 8.8m $\Omega$ N-CH 100V 8m $\Omega$	TO220-AB TO220	Vishay APEC	SUP90N10-8M8P AP85T10GP
0	Q2	NS		PowerPAK-SO8		
1	Q3	MMBTA06LT1G	NPN Transistor, 80V, 0.5A	SOT-23	DIODES	MMBTA06LT1G
0	D1	NS		SMB		
0	D2	NS		TO220		
1	D3	DIODES	75V/0.15A	SOD323		IN4148WS-7-F
1	D4	BZT52C20	ZENER DIODE, 20V	SOT-123	DIODES	BZT52C20-F
1	U1	MP6902DS	MP6902DS	SO-8	MPS	MP6902DS

### PRINTED CIRCUIT BOARD LAYOUT

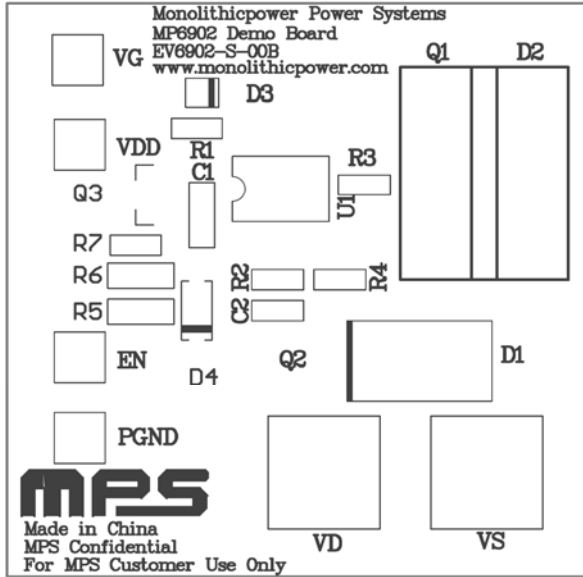

Figure 1—Top Silk Layer

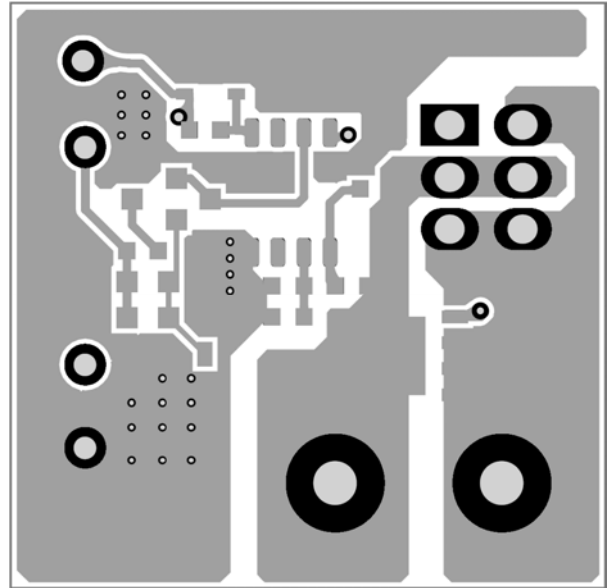

Figure 2—Top Layer

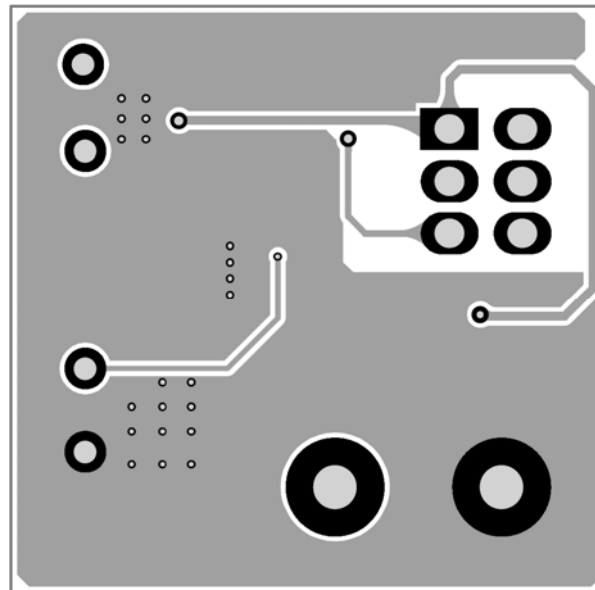

Figure 3—Bottom Layer

## QUICK START GUIDE

### Using external power supply to power the SR IC

1. Connect the positive and negative terminals of the power supply to the VDD and PGND pins, respectively.
2. Preset the power supply output 8V~24V, then turn off the power supply.
3. Connect the Drain and Source and Gate terminals of the synchronous power MOSFET to the VD and VS and VG pins, respectively (There is already a 100V power MOSFET Q1 connected on the board, if the customer do not want to use this MOS as synchronous MOSFET, you can remove this Q1 and use your own MOSFET instead).
4. Turn the power supply on. The IC will automatically startup and drive the synchronous MOSFET Q1 to work as an ideal diode.

### Using drain of the MOSFET or system output to power the SR IC (without external power supply)

1. Connect the VDD terminal of the EVB to the Drain of the synchronous power MOSFET or system output.
2. Connect the Drain and Source and Gate terminals of the synchronous power MOSFET to the VD and VS and VG pins, respectively (There is already a 100V power MOSFET Q1 connected on the board, if the customer do not want to use this MOS as synchronous MOSFET, you can remove this Q1 and use your own MOSFET instead).
3. The IC will automatically startup and drive the synchronous MOSFET Q1 to work as an ideal diode.

**NOTICE:** The information in this document is subject to change without notice. Users should warrant and guarantee that third party Intellectual Property rights are not infringed upon when integrating MPS products into any application. MPS will not assume any legal responsibility for any said applications.