

# CDCVF2505

## 3.3-V CLOCK PHASE-LOCK LOOP CLOCK DRIVER

SCAS640E – JULY 2000 – REVISED MARCH 2005

- Phase-Lock Loop Clock Driver for Synchronous DRAM and General-Purpose Applications
- Spread Spectrum Clock Compatible
- Operating Frequency: 24 MHz to 200 MHz
- Low Jitter (Cycle-cycle):  $<|150\text{ ps}|$  Over the Range 66 MHz–200 MHz
- Distributes One Clock Input to One Bank of Five Outputs (CLKOUT Is Used to Tune the Input-Output Delay)
- Three-States Outputs When There Is no Input Clock
- Operates From Single 3.3-V Supply
- Available in 8-Pin TSSOP and 8-Pin SOIC Packages
- Consumes Less Than 100  $\mu\text{A}$  (Typically) in Power Down Mode
- Internal Feedback Loop Is Used to Synchronize the Outputs to the Input Clock
- 25- $\Omega$  On-Chip Series Damping Resistors
- Integrated RC PLL Loop Filter Eliminates the Need for External Components

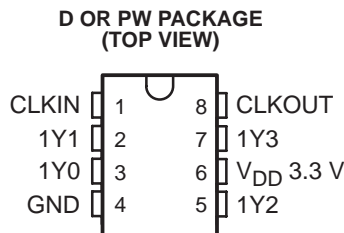

### description

The CDCVF2505 is a high-performance, low-skew, low-jitter, phase-lock loop (PLL) clock driver. It uses a PLL to precisely align, in both frequency and phase, the output clocks (1Y[0–3] and CLKOUT) to the input clock signal (CLKIN). The CDCVF2505 operates at 3.3 V. It also provides integrated series-damping resistors that make it ideal for driving point-to-point loads.

One bank of five outputs provides low-skew, low-jitter copies of CLKIN. Output duty cycles are adjusted to 50 percent, independent of duty cycle at CLKIN. The device automatically goes in power-down mode when no input signal is applied to CLKIN.

Unlike many products containing PLLs, the CDCVF2505 does not require an external RC network. The loop filter for the PLLs is included on-chip, minimizing component count, space, and cost.

Because it is based on the PLL circuitry, the CDCVF2505 requires a stabilization time to achieve phase lock of the feedback signal to the reference signal. This stabilization is required following power up and application of a fixed-frequency, fixed-phase signal at CLKIN, and following any changes to the PLL reference.

The CDCVF2505 is characterized for operation from  $-40^{\circ}\text{C}$  to  $85^{\circ}\text{C}$ .



Please be aware that an important notice concerning availability, standard warranty, and use in critical applications of Texas Instruments semiconductor products and disclaimers thereto appears at the end of this data sheet.

PRODUCTION DATA information is current as of publication date. Products conform to specifications per the terms of Texas Instruments standard warranty. Production processing does not necessarily include testing of all parameters.

 **TEXAS  
INSTRUMENTS**

POST OFFICE BOX 655303 • DALLAS, TEXAS 75265

Copyright © 2000 – 2005, Texas Instruments Incorporated

# CDCVF2505

## 3.3-V CLOCK PHASE-LOCK LOOP CLOCK DRIVER

SCAS640E – JULY 2000 – REVISED MARCH 2005

FUNCTION TABLE

INPUT	OUTPUTS	
CLKIN	1Y (0:3)	CLKOUT
L	L	L
H	H	H
<10 MHz†	Z	Z

† Typically, below 2 MHz the device goes in power-down mode in which the PLL is turned off and the outputs enter into Hi-Z mode. If a >10-MHz signal is applied at CLKIN the PLL turns on, reacquires lock, and stabilizes after approximately 100 μs. The outputs will then be enabled.

### functional block diagram

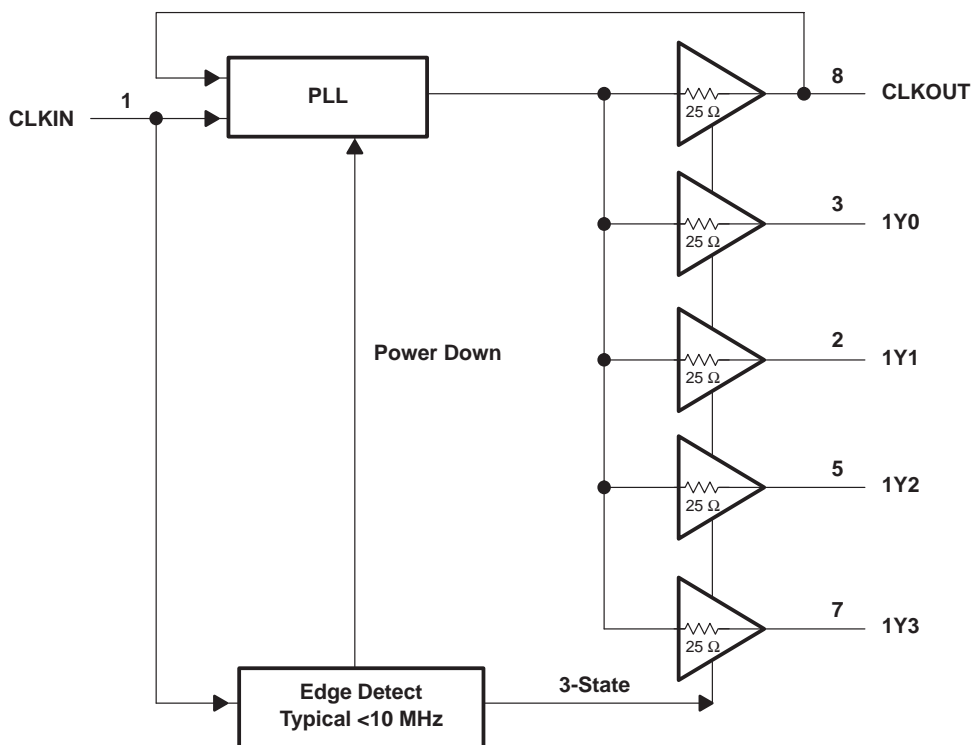

# CDCVF2505

## 3.3-V CLOCK PHASE-LOCK LOOP CLOCK DRIVER

SCAS640E – JULY 2000 – REVISED MARCH 2005

### Terminal Functions

TERMINAL NAME	NO.	I/O	DESCRIPTION
1Y[0–3]	2, 3, 5, 7	O	Clock outputs. These outputs are low-skew copies of CLKIN. Each output has an integrated 25- $\Omega$ series damping resistor.
CLKIN	1	I	Clock input. CLKIN provides the clock signal to be distributed by the CDCVF2505 clock driver. CLKIN is used to provide the reference signal to the integrated PLL that generates the clock output signals. CLKIN must have a fixed frequency and fixed phase for the PLL to obtain phase lock. Once the circuit is powered up and a valid signal is applied, a stabilization time (100 $\mu$ s) is required for the PLL to phase lock the feedback signal to CLKIN.
CLKOUT	8	O	Feedback output. CLKOUT completes the internal feedback loop of the PLL. This connection is made inside the chip and an external feedback loop should NOT be connected. CLKOUT can be loaded with a capacitor to achieve zero delay between CLKIN and the Y outputs.
GND	4	Power	Ground
V <sub>DD3.3V</sub>	6	Power	3.3-V Supply

### absolute maximum ratings over operating free-air temperature (unless otherwise noted)†

Supply voltage range, V <sub>DD</sub>	–0.5 V to 4.3 V
Input voltage range, V <sub>I</sub> (see Notes 1 and 2)	–0.5 V to V <sub>DD</sub> + 0.5 V
Output voltage range, V <sub>O</sub> (see Notes 1 and 2)	–0.5 V to V <sub>DD</sub> + 0.5 V
Input clamp current, I <sub>IK</sub> (V <sub>I</sub> < 0 or V <sub>I</sub> > V <sub>DD</sub> )	±50 mA
Output clamp current, I <sub>OK</sub> (V <sub>O</sub> < 0 or V <sub>O</sub> > V <sub>DD</sub> )	±50 mA
Continuous total output current, I <sub>O</sub> (V <sub>O</sub> = 0 to V <sub>DD</sub> )	±50 mA
Package thermal impedance, $\theta_{JA}$ (see Note 3): D package	165.5°C/W
PWR package	230.5°C/W
Storage temperature range, T <sub>stg</sub>	–65°C to 150°C

† Stresses beyond those listed under “absolute maximum ratings” may cause permanent damage to the device. These are stress ratings only, and functional operation of the device at these or any other conditions beyond those indicated under “recommended operating conditions” is not implied. Exposure to absolute-maximum-rated conditions for extended periods may affect device reliability.

- NOTES:
1. The input and output negative-voltage ratings may be exceeded if the input and output clamp-current ratings are observed.
  2. This value is limited to 4.3 V maximum.
  3. The package thermal impedance is calculated in accordance with JESD 51.

### recommended operating conditions

	MIN	NOM	MAX	UNIT
Supply voltage, V <sub>DD</sub>	3	3.3	3.6	V
High-level input voltage, V <sub>IH</sub>	0.7 V <sub>DD</sub>			V
Low-level input voltage, V <sub>IL</sub>	0.3 V <sub>DD</sub>			V
Input voltage, V <sub>I</sub>	0	V <sub>DD</sub>		V
High-level output current, I <sub>OH</sub>	–12			mA
Low-level output current, I <sub>OL</sub>	12			mA
Operating free-air temperature, T <sub>A</sub>	–40	85		°C



# CDCVF2505

## 3.3-V CLOCK PHASE-LOCK LOOP CLOCK DRIVER

SCAS640E – JULY 2000 – REVISED MARCH 2005

### timing requirements over recommended ranges of supply voltage and operating free-air temperature

		MIN	NOM	MAX	UNIT
$f_{clk}$	Clock frequency	24		200	MHz
	Input clock duty cycle	24 MHz – 85 MHz (see Note 4)		30%	85%
		86 MHz – 200 MHz		40%	50% 60%
Stabilization time (see Note 5)				100	$\mu$ s

NOTES: 4. Ensured by design but not 100% production tested.

5. Time required for the integrated PLL circuit to obtain phase lock of its feedback signal to its reference signal. For phase lock to be obtained, a fixed-frequency, fixed-phase reference signal must be present at CLKIN. Until phase lock is obtained, the specifications for propagation delay, skew, and jitter parameters given in the switching characteristics table are not applicable. This parameter does not apply for input modulation under SSC application.

### electrical characteristics over recommended operating free-air temperature range (unless otherwise noted)

PARAMETER		TEST CONDITIONS	$V_{DD}$	MIN	TYP†	MAX	UNIT
$V_{IK}$	Input voltage	$I_I = -18$ mA	3 V			-1.2	V
$V_{OH}$	High-level output voltage	$I_{OH} = -100$ $\mu$ A	MIN to MAX	$V_{DD}-0.2$			V
		$I_{OH} = -12$ mA	3 V	2.1			
		$I_{OH} = -6$ mA	3 V	2.4			
$V_{OL}$	Low-level output voltage	$I_{OL} = 100$ $\mu$ A	MIN to MAX			0.2	V
		$I_{OL} = 12$ mA	3 V			0.8	
		$I_{OL} = 6$ mA	3 V			0.55	
$I_{OH}$	High-level output current	$V_O = 1$ V	3 V			-27	mA
		$V_O = 1.65$ V	3.3 V			-36	
$I_{OL}$	Low-level output current	$V_O = 2$ V	3 V			27	mA
		$V_O = 1.65$ V	3.3 V			40	
$I_I$	Input current	$V_I = 0$ V or $V_{DD}$				$\pm 5$	$\mu$ A
$C_i$	Input capacitance	$V_I = 0$ V or $V_{DD}$	3.3 V		4.2		pF
$C_o$	Output capacitance	$Y_n$	$V_I = 0$ V or $V_{DD}$	3.3 V	2.8		pF
		CLKOUT			5.2		

† All typical values are at respective nominal  $V_{DD}$  and 25°C.

### switching characteristics over recommended ranges of supply voltage and operating free-air temperature, $C_L = 25$ pF, $V_{DD} = 3.3$ V $\pm$ 0.3 V (see Note 5)

PARAMETER		TEST CONDITIONS	MIN	TYP†	MAX	UNIT
$t_{pd}$	Propagation delay (normalized (see Figure 3))	CLKIN to $Y_n$ , $f = 66$ MHz to 200 MHz	-150		150	ps
$t_{sk(o)}$	Output skew (see Note 6)	$Y_n$ to $Y_n$			150	ps
$t_{c(jit\_cc)}$	Jitter (cycle to cycle) (see Figure 5)	$f = 66$ MHz to 200 MHz		70	150	ps
		$f = 24$ MHz to 50 MHz		200	400	
odc	Output duty cycle (see Figure 4)	$f = 24$ MHz to 200 MHz at 50% $V_{DD}$	45%		55%	
$t_r$	Rise time	$V_O = 0.4$ V to 2 V	0.5		2	ns
$t_f$	Fall time	$V_O = 2$ V to 0.4 V	0.5		2	ns

† All typical values are at respective nominal  $V_{DD}$  and 25°C.

NOTE 6: The  $t_{sk(o)}$  specification is only valid for equal loading of all outputs.



# CDCVF2505

## 3.3-V CLOCK PHASE-LOCK LOOP CLOCK DRIVER

SCAS640E – JULY 2000 – REVISED MARCH 2005

### ESD information

ESD MODELS		LIMIT
Human Body Model (HBM)		2.0 kV
Machine Model (MM)		300 V
Charge Device Model (CDM)		1 kV

### thermal information

CDCVF2505 8-PIN SOIC			THERMAL AIR FLOW (CFM)				UNIT
			0	150	250	500	
R <sub>θJA</sub>	High K		97	87	83	77	°C/W
R <sub>θJA</sub>	Low K		165	126	113	97	°C/W
R <sub>θJC</sub>	High K	39					°C/W
R <sub>θJC</sub>	Low K	42					°C/W

CDCVF2505 8-PIN TSSOP			THERMAL AIR FLOW (CFM)				UNIT
			0	150	250	500	
R <sub>θJA</sub>	High K		149	142	138	132	°C/W
R <sub>θJA</sub>	Low K		230	185	170	150	°C/W
R <sub>θJC</sub>	High K	65					°C/W
R <sub>θJC</sub>	Low K	69					°C/W

### TYPICAL CHARACTERISTICS

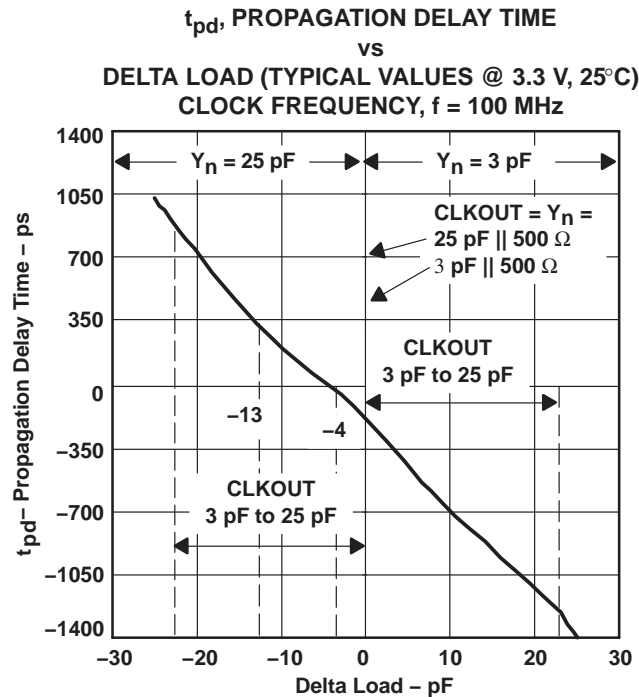

Figure 1

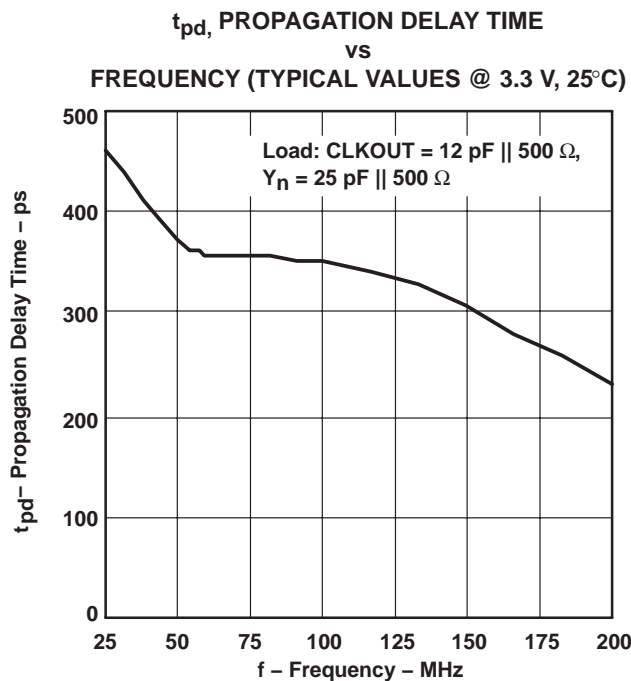

Figure 2

NOTE: Delta Load = CLKOUT Load – Yn Load



# CDCVF2505

## 3.3-V CLOCK PHASE-LOCK LOOP CLOCK DRIVER

SCAS640E – JULY 2000 – REVISED MARCH 2005

### TYPICAL CHARACTERISTICS

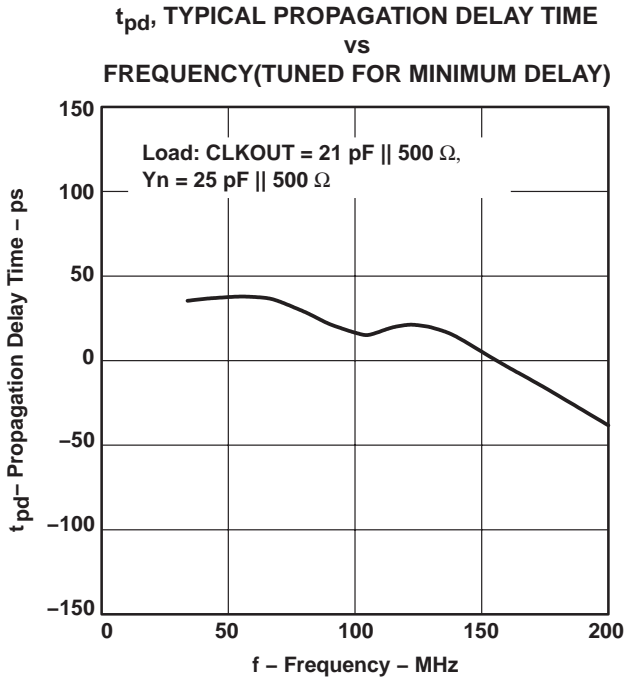

Figure 3

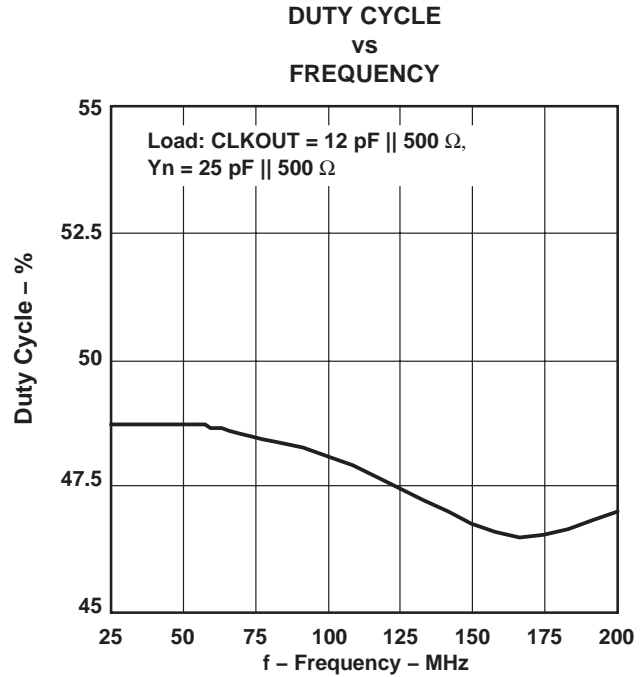

Figure 4

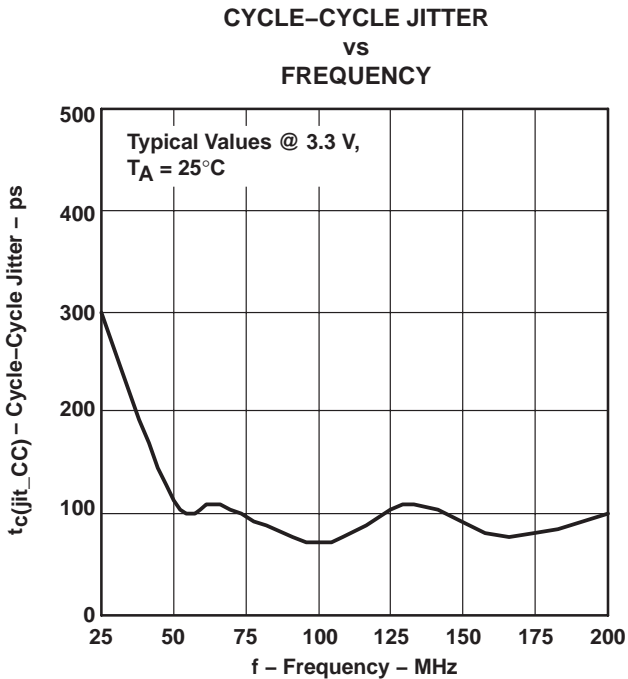

Figure 5

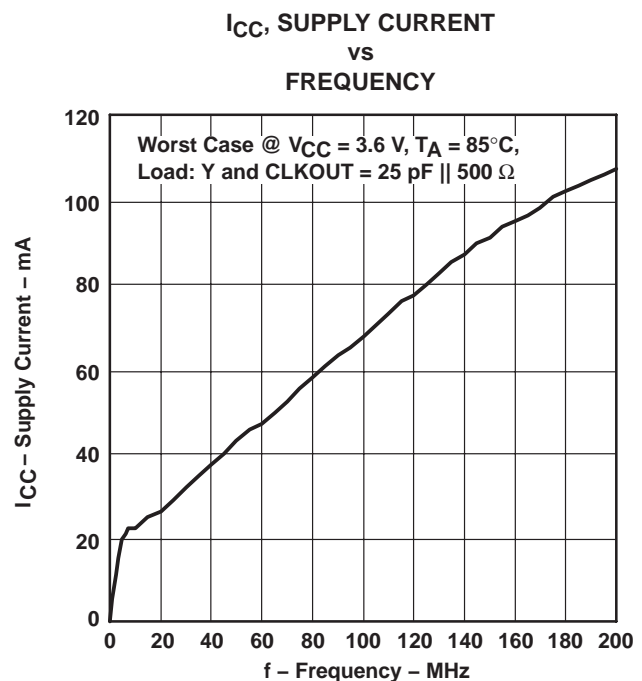
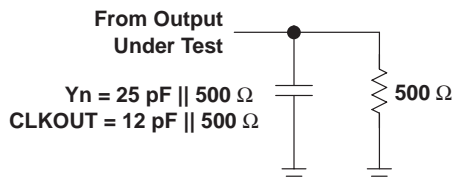
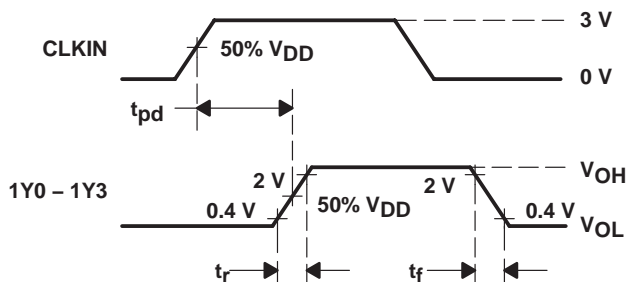

Figure 6

**PARAMETER MEASUREMENT INFORMATION**



**Figure 7. Test Load Circuit**



**Figure 8. Voltage Threshold for Measurements, Propagation Delay ( $t_{pd}$ )**

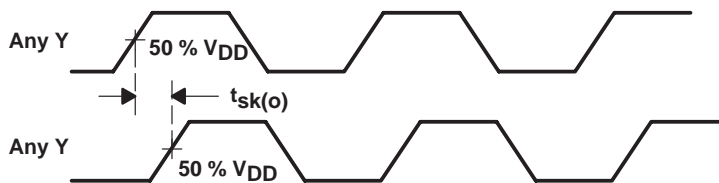

**Figure 9. Output Skew**

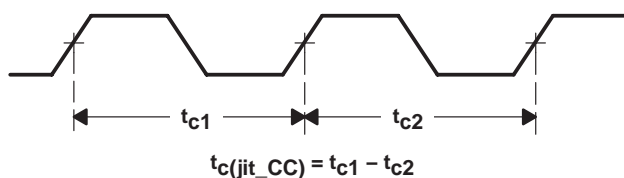

**Figure 10. Cycle-to-Cycle Jitter**

**PACKAGING INFORMATION**

Orderable Device	Status <sup>(1)</sup>	Package Type	Package Drawing	Pins	Package Qty	Eco Plan <sup>(2)</sup>	Lead/ Ball Finish	MSL Peak Temp <sup>(3)</sup>	Samples (Requires Login)
CDCVF2505D	ACTIVE	SOIC	D	8	75	Green (RoHS & no Sb/Br)	CU NIPDAU	Level-1-260C-UNLIM	<a href="#">Request Free Samples</a>
CDCVF2505DG4	ACTIVE	SOIC	D	8	75	Green (RoHS & no Sb/Br)	CU NIPDAU	Level-1-260C-UNLIM	<a href="#">Request Free Samples</a>
CDCVF2505DR	ACTIVE	SOIC	D	8	2500	Green (RoHS & no Sb/Br)	CU NIPDAU	Level-1-260C-UNLIM	<a href="#">Purchase Samples</a>
CDCVF2505DRG4	ACTIVE	SOIC	D	8	2500	Green (RoHS & no Sb/Br)	CU NIPDAU	Level-1-260C-UNLIM	<a href="#">Purchase Samples</a>
CDCVF2505PW	ACTIVE	TSSOP	PW	8	150	Green (RoHS & no Sb/Br)	CU NIPDAU	Level-1-260C-UNLIM	<a href="#">Request Free Samples</a>
CDCVF2505PWR	ACTIVE	TSSOP	PW	8	2000	Green (RoHS & no Sb/Br)	CU NIPDAU	Level-1-260C-UNLIM	<a href="#">Purchase Samples</a>
CDCVF2505PWRG4	ACTIVE	TSSOP	PW	8	2000	Green (RoHS & no Sb/Br)	CU NIPDAU	Level-1-260C-UNLIM	<a href="#">Purchase Samples</a>

<sup>(1)</sup> The marketing status values are defined as follows:

**ACTIVE:** Product device recommended for new designs.

**LIFEBUY:** TI has announced that the device will be discontinued, and a lifetime-buy period is in effect.

**NRND:** Not recommended for new designs. Device is in production to support existing customers, but TI does not recommend using this part in a new design.

**PREVIEW:** Device has been announced but is not in production. Samples may or may not be available.

**OBSOLETE:** TI has discontinued the production of the device.

<sup>(2)</sup> Eco Plan - The planned eco-friendly classification: Pb-Free (RoHS), Pb-Free (RoHS Exempt), or Green (RoHS & no Sb/Br) - please check <http://www.ti.com/productcontent> for the latest availability information and additional product content details.

**TBD:** The Pb-Free/Green conversion plan has not been defined.

**Pb-Free (RoHS):** TI's terms "Lead-Free" or "Pb-Free" mean semiconductor products that are compatible with the current RoHS requirements for all 6 substances, including the requirement that lead not exceed 0.1% by weight in homogeneous materials. Where designed to be soldered at high temperatures, TI Pb-Free products are suitable for use in specified lead-free processes.

**Pb-Free (RoHS Exempt):** This component has a RoHS exemption for either 1) lead-based flip-chip solder bumps used between the die and package, or 2) lead-based die adhesive used between the die and leadframe. The component is otherwise considered Pb-Free (RoHS compatible) as defined above.

**Green (RoHS & no Sb/Br):** TI defines "Green" to mean Pb-Free (RoHS compatible), and free of Bromine (Br) and Antimony (Sb) based flame retardants (Br or Sb do not exceed 0.1% by weight in homogeneous material)

<sup>(3)</sup> MSL, Peak Temp. -- The Moisture Sensitivity Level rating according to the JEDEC industry standard classifications, and peak solder temperature.

**Important Information and Disclaimer:** The information provided on this page represents TI's knowledge and belief as of the date that it is provided. TI bases its knowledge and belief on information provided by third parties, and makes no representation or warranty as to the accuracy of such information. Efforts are underway to better integrate information from third parties. TI has taken and

continues to take reasonable steps to provide representative and accurate information but may not have conducted destructive testing or chemical analysis on incoming materials and chemicals. TI and TI suppliers consider certain information to be proprietary, and thus CAS numbers and other limited information may not be available for release.

In no event shall TI's liability arising out of such information exceed the total purchase price of the TI part(s) at issue in this document sold by TI to Customer on an annual basis.

**OTHER QUALIFIED VERSIONS OF CDCVF2505 :**

- Automotive: [CDCVF2505-Q1](#)

NOTE: Qualified Version Definitions:

- Automotive - Q100 devices qualified for high-reliability automotive applications targeting zero defects

**TAPE AND REEL INFORMATION**
**REEL DIMENSIONS**

**TAPE DIMENSIONS**

A0	Dimension designed to accommodate the component width
B0	Dimension designed to accommodate the component length
K0	Dimension designed to accommodate the component thickness
W	Overall width of the carrier tape
P1	Pitch between successive cavity centers

**TAPE AND REEL INFORMATION**

\*All dimensions are nominal

Device	Package Type	Package Drawing	Pins	SPQ	Reel Diameter (mm)	Reel Width W1 (mm)	A0 (mm)	B0 (mm)	K0 (mm)	P1 (mm)	W (mm)	Pin1 Quadrant
CDCVF2505DR	SOIC	D	8	2500	330.0	12.4	6.4	5.2	2.1	8.0	12.0	Q1
CDCVF2505PWR	TSSOP	PW	8	2000	330.0	12.4	7.0	3.6	1.6	8.0	12.0	Q1

**TAPE AND REEL BOX DIMENSIONS**



\*All dimensions are nominal

Device	Package Type	Package Drawing	Pins	SPQ	Length (mm)	Width (mm)	Height (mm)
CDCVF2505DR	SOIC	D	8	2500	367.0	367.0	35.0
CDCVF2505PWR	TSSOP	PW	8	2000	367.0	367.0	35.0

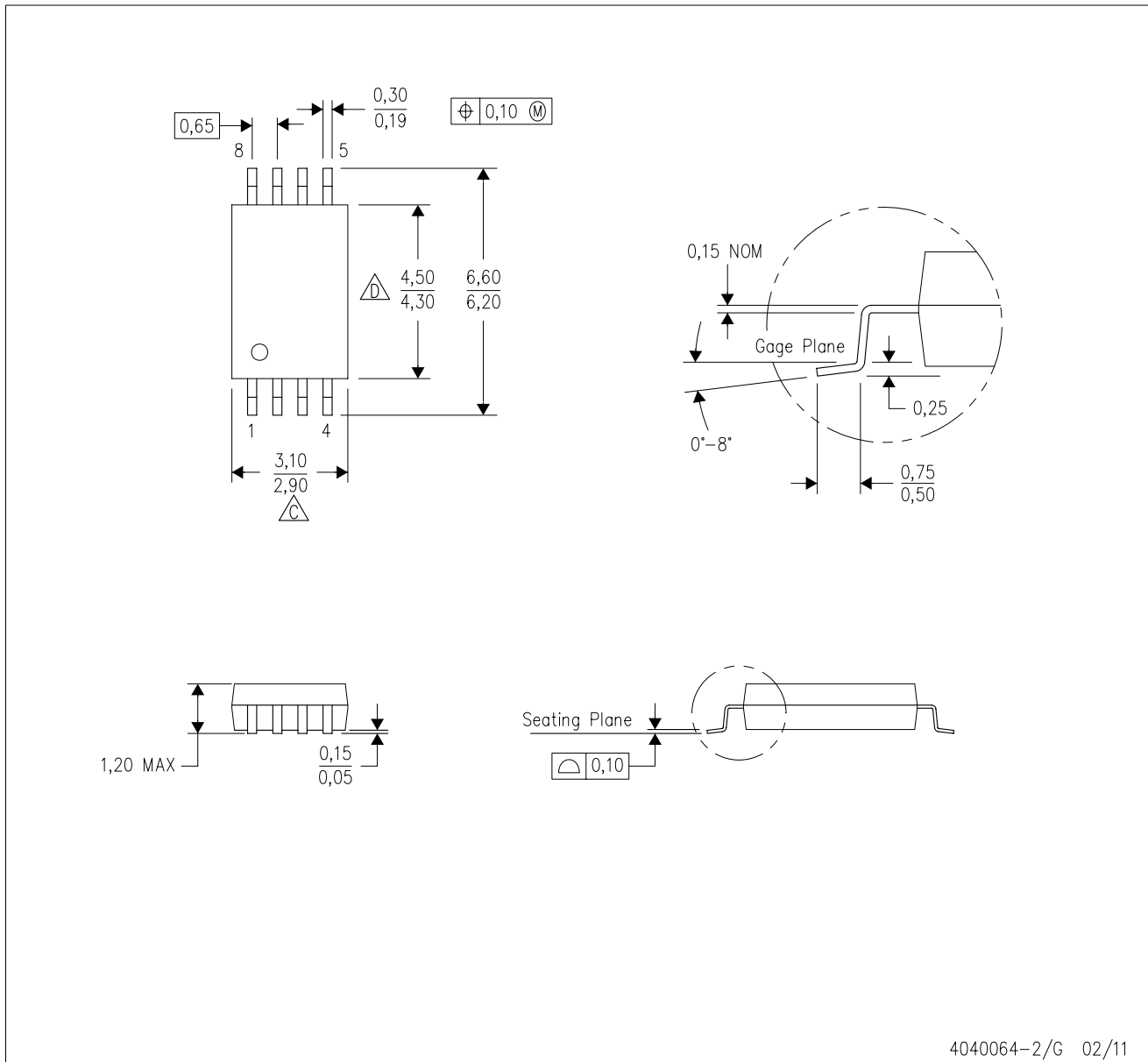

PW (R-PDSO-G8)

PLASTIC SMALL OUTLINE



4040064-2/G 02/11

- NOTES:
- A. All linear dimensions are in millimeters. Dimensioning and tolerancing per ASME Y14.5M-1994.
  - B. This drawing is subject to change without notice.
  -  Body length does not include mold flash, protrusions, or gate burrs. Mold flash, protrusions, or gate burrs shall not exceed 0,15 each side.
  -  Body width does not include interlead flash. Interlead flash shall not exceed 0,25 each side.
  - E. Falls within JEDEC MO-153

## IMPORTANT NOTICE

Texas Instruments Incorporated and its subsidiaries (TI) reserve the right to make corrections, enhancements, improvements and other changes to its semiconductor products and services per JESD46C and to discontinue any product or service per JESD48B. Buyers should obtain the latest relevant information before placing orders and should verify that such information is current and complete. All semiconductor products (also referred to herein as "components") are sold subject to TI's terms and conditions of sale supplied at the time of order acknowledgment.

TI warrants performance of its components to the specifications applicable at the time of sale, in accordance with the warranty in TI's terms and conditions of sale of semiconductor products. Testing and other quality control techniques are used to the extent TI deems necessary to support this warranty. Except where mandated by applicable law, testing of all parameters of each component is not necessarily performed.

TI assumes no liability for applications assistance or the design of Buyers' products. Buyers are responsible for their products and applications using TI components. To minimize the risks associated with Buyers' products and applications, Buyers should provide adequate design and operating safeguards.

TI does not warrant or represent that any license, either express or implied, is granted under any patent right, copyright, mask work right, or other intellectual property right relating to any combination, machine, or process in which TI components or services are used. Information published by TI regarding third-party products or services does not constitute a license to use such products or services or a warranty or endorsement thereof. Use of such information may require a license from a third party under the patents or other intellectual property of the third party, or a license from TI under the patents or other intellectual property of TI.

Reproduction of significant portions of TI information in TI data books or data sheets is permissible only if reproduction is without alteration and is accompanied by all associated warranties, conditions, limitations, and notices. TI is not responsible or liable for such altered documentation. Information of third parties may be subject to additional restrictions.

Resale of TI components or services with statements different from or beyond the parameters stated by TI for that component or service voids all express and any implied warranties for the associated TI component or service and is an unfair and deceptive business practice. TI is not responsible or liable for any such statements.

Buyer acknowledges and agrees that it is solely responsible for compliance with all legal, regulatory and safety-related requirements concerning its products, and any use of TI components in its applications, notwithstanding any applications-related information or support that may be provided by TI. Buyer represents and agrees that it has all the necessary expertise to create and implement safeguards which anticipate dangerous consequences of failures, monitor failures and their consequences, lessen the likelihood of failures that might cause harm and take appropriate remedial actions. Buyer will fully indemnify TI and its representatives against any damages arising out of the use of any TI components in safety-critical applications.

In some cases, TI components may be promoted specifically to facilitate safety-related applications. With such components, TI's goal is to help enable customers to design and create their own end-product solutions that meet applicable functional safety standards and requirements. Nonetheless, such components are subject to these terms.

No TI components are authorized for use in FDA Class III (or similar life-critical medical equipment) unless authorized officers of the parties have executed a special agreement specifically governing such use.

Only those TI components which TI has specifically designated as military grade or "enhanced plastic" are designed and intended for use in military/aerospace applications or environments. Buyer acknowledges and agrees that any military or aerospace use of TI components which have **not** been so designated is solely at the Buyer's risk, and that Buyer is solely responsible for compliance with all legal and regulatory requirements in connection with such use.

TI has specifically designated certain components which meet ISO/TS16949 requirements, mainly for automotive use. Components which have not been so designated are neither designed nor intended for automotive use; and TI will not be responsible for any failure of such components to meet such requirements.

### Products

Audio	<a href="http://www.ti.com/audio">www.ti.com/audio</a>
Amplifiers	<a href="http://amplifier.ti.com">amplifier.ti.com</a>
Data Converters	<a href="http://dataconverter.ti.com">dataconverter.ti.com</a>
DLP® Products	<a href="http://www.dlp.com">www.dlp.com</a>
DSP	<a href="http://dsp.ti.com">dsp.ti.com</a>
Clocks and Timers	<a href="http://www.ti.com/clocks">www.ti.com/clocks</a>
Interface	<a href="http://interface.ti.com">interface.ti.com</a>
Logic	<a href="http://logic.ti.com">logic.ti.com</a>
Power Mgmt	<a href="http://power.ti.com">power.ti.com</a>
Microcontrollers	<a href="http://microcontroller.ti.com">microcontroller.ti.com</a>
RFID	<a href="http://www.ti-rfid.com">www.ti-rfid.com</a>
OMAP Mobile Processors	<a href="http://www.ti.com/omap">www.ti.com/omap</a>
Wireless Connectivity	<a href="http://www.ti.com/wirelessconnectivity">www.ti.com/wirelessconnectivity</a>

### Applications

Automotive and Transportation	<a href="http://www.ti.com/automotive">www.ti.com/automotive</a>
Communications and Telecom	<a href="http://www.ti.com/communications">www.ti.com/communications</a>
Computers and Peripherals	<a href="http://www.ti.com/computers">www.ti.com/computers</a>
Consumer Electronics	<a href="http://www.ti.com/consumer-apps">www.ti.com/consumer-apps</a>
Energy and Lighting	<a href="http://www.ti.com/energy">www.ti.com/energy</a>
Industrial	<a href="http://www.ti.com/industrial">www.ti.com/industrial</a>
Medical	<a href="http://www.ti.com/medical">www.ti.com/medical</a>
Security	<a href="http://www.ti.com/security">www.ti.com/security</a>
Space, Avionics and Defense	<a href="http://www.ti.com/space-avionics-defense">www.ti.com/space-avionics-defense</a>
Video and Imaging	<a href="http://www.ti.com/video">www.ti.com/video</a>

**TI E2E Community** [e2e.ti.com](http://e2e.ti.com)