

### 1. PART NO. EXPRESSION :

**SCI0603S-1N6KF**

(a) (b) (c) (d) (e)(f)

(a) Series code

(b) Dimension code

(c) Type code : S ( Standard )

(d) Inductance code : 1N6 = 1.6nH

(e) Tolerance code : G = ±2%, J = ±5%, K = ±10%

(f) F : RoHS Compliant

### 2. CONFIGURATION & DIMENSIONS :

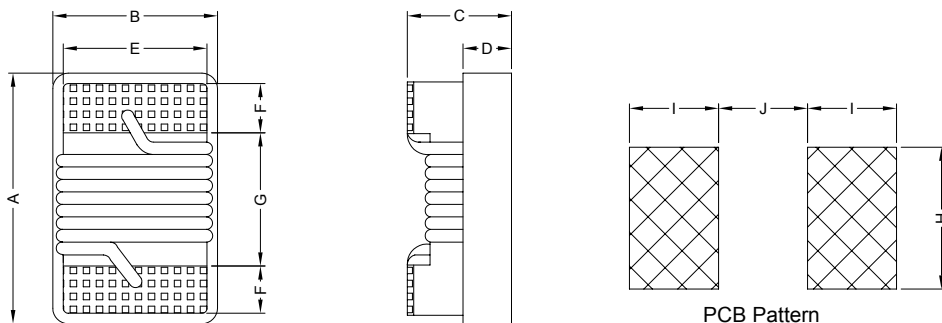

PCB Pattern

Unit:m/m

A	B	C	D	E	F	G	H	I	J
1.80 Max.	1.12 Max.	1.02 Max.	0.38 Ref.	0.76 Ref.	0.33 Ref.	0.86 Ref.	1.02 Ref.	0.64 Ref.	0.64 Ref.

### 3. SCHEMATIC :

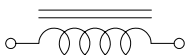

### 4. MATERIALS :

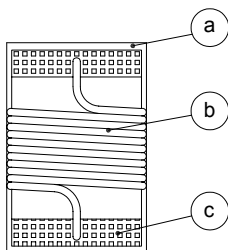

(a) Core : Ceramic U core

(b) Wire : Enamelled Copper Wire

(c) Terminal Metallization : Ag + Ni + Au



**RoHS Compliant**

NOTE : Specifications subject to change without notice. Please check our website for latest information.

28.01.2011



**SUPERWORLD ELECTRONICS (S) PTE LTD**

## 5. GENERAL SPECIFICATION :

- a) Storage temp. : -25°C to +80°C
- b) Operating temp. : -40°C to +125°C
- c) Temperature rise : 40°C Max.
- d) Rated current : Base on temp. rise &  $\Delta L/L0A=10\%$  Max.
- e) Resistance to solder heat : 260°C.10sec

## 6. ELECTRICAL CHARACTERISTICS :

Part No.	Tolerance Available	L ( nH )	Test Freq ( MHz )	Q Min.	SRF ( MHz ) Min.	DCR ( $\Omega$ ) Max.	IDC ( mA ) Max.	900MHz L Typ.	900MHz Q Typ.	1.7GHz L Typ.	1.7GHz Q Typ.
SCI0603S-1N6□F	K, J	1.6	250	16	12500	0.040	700	1.53	35	1.58	55
SCI0603S-1N8□F	K, J	1.8	250	16	12500	0.045	700	1.63	35	1.66	50
SCI0603S-2N2□F	K, J	2.2	250	20	6000	0.100	700	2.18	41	2.20	64
SCI0603S-3N3□F	K, J, G	3.3	250	22	>6000	0.080	700	3.35	47	3.40	65
SCI0603S-3N6□F	K, J, G	3.6	250	22	5800	0.063	700	3.53	49	3.58	65
SCI0603S-3N9□F	K, J, G	3.9	250	22	>6000	0.080	700	3.95	49	3.96	67
SCI0603S-4N3□F	K, J, G	4.3	250	22	5800	0.063	700	4.32	49	4.43	67
SCI0603S-4N7□F	K, J, G	4.7	250	20	5800	0.120	700	4.65	53	4.80	67
SCI0603S-5N1□F	K, J, G	5.1	250	20	5800	0.160	700	5.13	47	5.36	56
SCI0603S-5N6□F	K, J, G	5.6	250	20	5800	0.170	700	5.53	56	5.86	77
SCI0603S-6N8□F	K, J, G	6.8	250	27	5800	0.110	700	6.75	60	7.10	81
SCI0603S-7N5□F	K, J, G	7.5	250	27	4800	0.110	700	7.39	62	7.71	81
SCI0603S-8N2□F	K, J, G	8.2	250	27	4800	0.110	700	8.25	64	8.40	81
SCI0603S-8N7□F	K, J, G	8.7	250	27	4800	0.110	700	8.84	62	9.38	58
SCI0603S-9N5□F	K, J, G	9.5	250	27	4800	0.130	700	9.64	59	10.50	61
SCI0603S-10N□F	K, J, G	10	250	31	4800	0.130	700	10.0	66	10.60	83
SCI0603S-11N□F	K, J, G	11	250	31	4000	0.086	700	11.3	53	12.10	56
SCI0603S-12N□F	K, J, G	12	250	35	4000	0.130	700	12.3	72	13.50	83
SCI0603S-15N□F	K, J, G	15	250	35	4000	0.170	700	15.4	64	16.80	89
SCI0603S-16N□F	K, J, G	16	250	35	3300	0.110	700	16.5	55	18.00	52
SCI0603S-18N□F	K, J, G	18	250	35	3100	0.170	700	18.7	70	21.40	69
SCI0603S-22N□F	K, J, G	22	250	38	3000	0.190	700	22.8	73	26.10	71
SCI0603S-23N□F	K, J, G	23	250	38	2850	0.190	700	24.1	71	28.00	71
SCI0603S-24N□F	K, J, G	24	250	36	2800	0.130	700	25.7	45	30.90	40
SCI0603S-27N□F	K, J, G	27	250	40	2800	0.220	600	29.2	74	34.60	65



**RoHS Compliant**

NOTE : Specifications subject to change without notice. Please check our website for latest information.

28.01.2011



**SUPERWORLD ELECTRONICS (S) PTE LTD**

## 6. ELECTRICAL CHARACTERISTICS :

Part No.	Tolerance Available	L (nH)	Test Freq (MHz)	Q Min.	SRF (MHz) Min.	DCR ( $\Omega$ ) Max.	IDC (mA) Max.	900MHz L Typ.	900MHz Q Typ.	1.7GHz L Typ.	1.7GHz Q Typ.
SCI0603S-30N□F	K, J, G	30	250	37	2800	0.150	600	31.4	47	39.80	28
SCI0603S-33N□F	K, J, G	33	250	40	2300	0.220	600	36.0	67	49.50	42
SCI0603S-36N□F	K, J, G	36	250	37	2300	0.250	600	39.1	47	48.90	24
SCI0603S-39N□F	K, J, G	39	250	40	2200	0.250	600	42.7	60	60.20	40
SCI0603S-43N□F	K, J, G	43	200	38	2000	0.280	600	46.9	44	60.30	21
SCI0603S-47N□F	K, J, G	47	200	38	2000	0.280	600	52.2	62	77.20	35
SCI0603S-51N□F	K, J, G	51	200	35	1900	0.280	600	55.5	69	82.20	34
SCI0603S-56N□F	K, J, G	56	200	38	1900	0.310	600	62.5	56	97.00	26
SCI0603S-68N□F	K, J, G	68	200	37	1700	0.340	600	80.5	54	168.00	21
SCI0603S-72N□F	K, J, G	72	150	34	1700	0.490	400	82.0	53	135.00	20
SCI0603S-82N□F	K, J, G	82	150	34	1700	0.540	400	96.2	54	177.00	21
SCI0603S-R10□F	K, J, G	100	150	34	1400	0.580	400	124	49	-	-
SCI0603S-R11□F	K, J, G	110	150	32	1350	0.610	300	138	43	-	-
SCI0603S-R12□F	K, J, G	120	150	32	1300	0.650	300	166	39	-	-
SCI0603S-R15□F	K, J, G	150	100	32	1300	0.950	280	230	25	-	-
SCI0603S-R18□F	K, J, G	180	100	25	1250	1.400	250	305	22	-	-
SCI0603S-R22□F	K, J, G	220	100	25	1200	1.600	250	-	-	-	-
SCI0603S-R26□F	K, J, G	260	100	25	1200	2.000	200	-	-	-	-
SCI0603S-R27□F	K, J, G	270	100	25	900	2.100	200	-	-	-	-
SCI0603S-R33□F	K, J, G	330	100	25	900	3.800	100	-	-	-	-
SCI0603S-R39□F	K, J, G	390	100	25	900	4.350	100	-	-	-	-
SCI0603S-R47□F	K, J, G	470	100	23	600	3.600	80	-	-	-	-

Inductance tolerance :

- : G :  $\pm 2\%$
- J :  $\pm 5\%$
- K :  $\pm 10\%$



**RoHS Compliant**

NOTE : Specifications subject to change without notice. Please check our website for latest information.

28.01.2011



**SUPERWORLD ELECTRONICS (S) PTE LTD**

### 7. PACKAGING INFORMATION :

Reel Configuration :

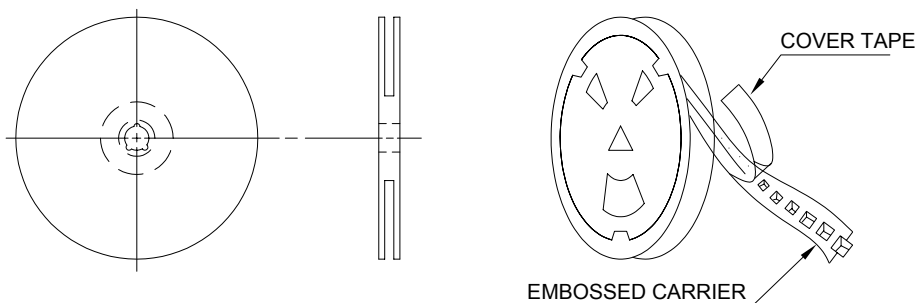

Paper Tape :

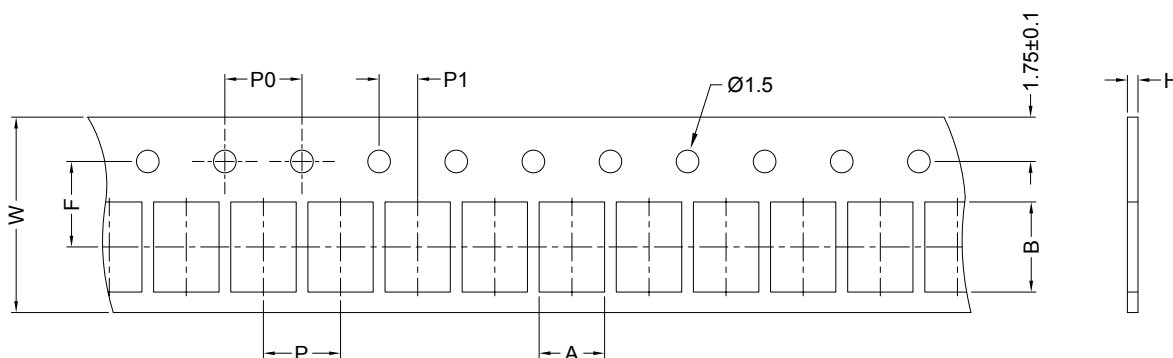

Dimension (unit: mm)

Series	A	B	H	F	P	P0	P1	W	Qty
SCI0402S	0.72	1.19	0.60	3.50	4.00	4.00	2.00	8.00	4000pcs / reel
SCI0603S	1.35	1.95	0.95	3.50	4.00	4.00	2.00	8.00	4000pcs / reel



**RoHS Compliant**

NOTE : Specifications subject to change without notice. Please check our website for latest information.

28.01.2011



**SUPERWORLD ELECTRONICS (S) PTE LTD**

Embossed Carrier Tape :

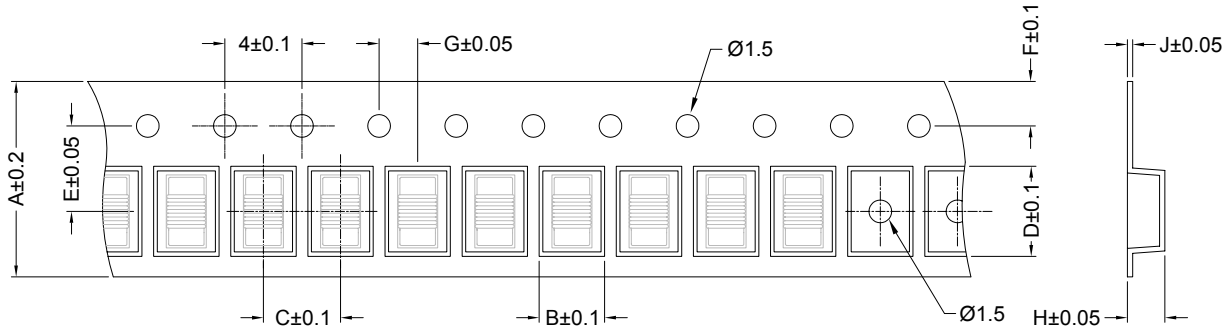

Dimension (unit: mm)

Series	A	B	C	D	E	F	G	H	J	Qty
SCI0805S	8	1.85	4	2.30	3.5	1.75	2	1.45	0.23	2000pcs / reel
SCI0805LP	8	1.80	4	2.30	3.5	1.75	2	0.90	0.23	2000pcs / reel
SCI0805HQ	8	1.85	4	2.30	3.5	1.75	2	1.45	0.23	2000pcs / reel
SCI1008S	8	2.70	4	2.80	3.5	1.75	2	2.00	0.23	2000pcs / reel
SCI1008LP	8	2.70	4	2.80	3.5	1.75	2	1.50	0.23	2000pcs / reel
SCI1008HQ	8	2.70	4	2.80	3.5	1.75	2	2.00	0.23	2000pcs / reel

Leader/Trailer Tape :

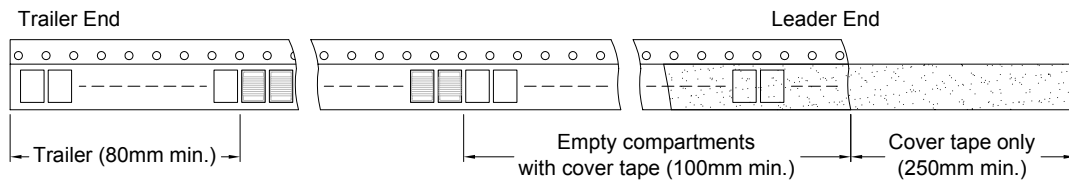

Peel-off Force :

Peel-off force should be in the range of 0.1N~0.7N at a peel-off speed of 300±10mm/min.

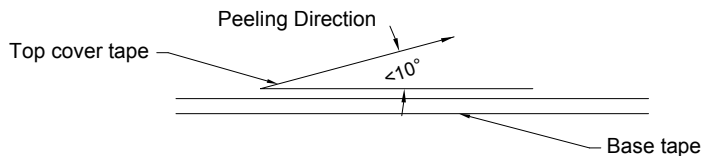

**RoHS Compliant**

NOTE : Specifications subject to change without notice. Please check our website for latest information.

28.01.2011



**SUPERWORLD ELECTRONICS (S) PTE LTD**

### 8. ENVIRONMENTAL CHARACTERISTICS :

Electrical Performance Test :

ITEM		SPECIFICATION	TEST CONDITIONS / TEST METHODS
1	Inductance	Refer to Electrical Characteristics List	HP4291B
2	Q		HP4291B
3	SRF		HP8753D
4	DC Resistance Rdc		Mico-Ohmmeter (GOM-801G)
5	Rated Current IDC		The device should be REFLOW soldered (230±5°C for 10 seconds) to a tinned copper subs rate. A dynamiter
6	Over Load Test	After test, inductors shall have no evidence of electrical and mechanical damage	Applied 2 times of rated allowed DC current to inductor for a period of 5 minute.
7	Withstanding Voltage Test	After test, inductors shall have no evidence of electrical and mechanical damage	AC voltage of 500VAC applied between inductors terminal and case for 1 minute.
8	Insulation Resistance Test	1000 MOhm min.	100VDC applied between inductor terminal and case



**RoHS Compliant**

NOTE : Specifications subject to change without notice. Please check our website for latest information.

28.01.2011



**SUPERWORLD ELECTRONICS (S) PTE LTD**

Mechanical Performance Test :

ITEM		SPECIFICATION	TEST CONDITIONS / TEST METHODS
1	Vibration	Appearance : No damage L change : within $\pm 5\%$ Q change : within $\pm 10\%$	Test device shall be soldered on the substrate Oscillation Frequency : 10 to 55 to 10Hz for 1 min. Amplitude : 1.5mm Time : 2hrs for each axis (X, Y, Z), total 6hrs.
2	Resistance to Soldering Heat	Appearance : No damage L change : within $\pm 5\%$ Q change : within $\pm 10\%$	Pre-heating : 150°C, 1 min Solder Composition : Sn/Pb=63/67 Solder Temperature : 230 $\pm$ 5°C Immersion Time : 20 $\pm$ 2sec Solder Temperature : 260 $\pm$ 5°C Immersion Time : 5 $\pm$ 2sec
3	Component Adhesion (Push Test)	1 lbs. For 0402 2 lbs. For 0603 3 lbs. For the rest	The device should be REFLOW soldered (230 $\pm$ 5°C for 10 seconds) to a tinned copper subs rate. A dynamiter force gauge should be applied to the side of the component. The device must withstand a minimum force of 2 or 4 pounds without a failure of the termination attached to component.
3	Component Adhesion (Push Test)	The electrodes shall be at least 90% covered with new solder coating.	Pre-heating : 150°C, 1min Solder Composition : Sn/Pb=63/67 Solder Temperature : 230 $\pm$ 5°C Immersion Time : 4 $\pm$ 1sec
4	Drop Test	After test, the chip inductor don't fell of broke on the P.C.Board	Drop 1 time for each face and 1 time for each corner. Total drop 10 times. Drop Height : 100cm Drop Weight : 125g
5	Solderability Test	The terminal should at least be 90% covered with solder	after fluxing (alpha 100 or equiv), inductor shall be dipped in a melted solder bath at 232 $\pm$ 5°C for 5 seconds.
6	Resistance to solvent test	There shall be no case of deformation change in appearance of obliteration of marking	MIL-STD202F, METHOD 215D



**RoHS Compliant**

NOTE : Specifications subject to change without notice. Please check our website for latest information.

28.01.2011



**SUPERWORLD ELECTRONICS (S) PTE LTD**

PG. 7

Climatic Test :

ITEM		SPECIFICATION	TEST CONDITIONS / TEST METHODS															
1	Temperature Characteristics	Appearance : No damage L change : within $\pm 10\%$ Q change : within $\pm 20\%$	-40°C ~ +125°C															
2	Humidity Resistance		Temperature : 40 $\pm$ 2°C Relative Humidity : 90~95% Time : 96hrs $\pm$ 2hrs Measured after exposure in the room condition for 2hrs															
3	Low Temperature Storage Test		Temperature : -40 $\pm$ 2°C Time : 48 $\pm$ 2hrs Inductors are to be tested after 1 hour at room temperature.															
4	Thermal Shock Test		One cycle : <table border="1" style="margin-left: 20px;"> <thead> <tr> <th>Step</th> <th>Temperature (°C)</th> <th>Time (min)</th> </tr> </thead> <tbody> <tr> <td>1</td> <td>-25<math>\pm</math>3</td> <td>30</td> </tr> <tr> <td>2</td> <td>25<math>\pm</math>2</td> <td>15</td> </tr> <tr> <td>3</td> <td>85<math>\pm</math>3</td> <td>30</td> </tr> <tr> <td>4</td> <td>25<math>\pm</math>2</td> <td>15</td> </tr> </tbody> </table> Total : 5 cycles	Step	Temperature (°C)	Time (min)	1	-25 $\pm$ 3	30	2	25 $\pm$ 2	15	3	85 $\pm$ 3	30	4	25 $\pm$ 2	15
Step	Temperature (°C)		Time (min)															
1	-25 $\pm$ 3		30															
2	25 $\pm$ 2		15															
3	85 $\pm$ 3	30																
4	25 $\pm$ 2	15																
5	High Temperature Storage Test	Temperature : 125 $\pm$ 2°C Time : 48 $\pm$ 2hrs Load : Allowed DC current																
6	High Temperature Load Life Test	Temperature : 85 $\pm$ 2°C Time : 1000 $\pm$ 12hrs Load : Allowed DC current																
7	Humidity Load Life	Temperature : 40 $\pm$ 2°C Relative Humidity : 90~95% Time : 1000 $\pm$ 12hrs Load : Allowed DC current																



**RoHS Compliant**

NOTE : Specifications subject to change without notice. Please check our website for latest information.

28.01.2011



**SUPERWORLD ELECTRONICS (S) PTE LTD**