

HOW TO ORDER

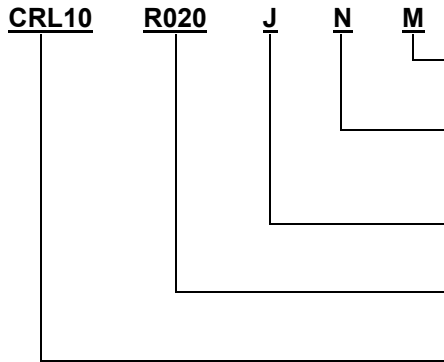

Packaging
M = Tape/Reel B = Bulk

TCR (PPM/°C)
K=±100 L=±200 N=±300
O=±400 Q=±600 M=±500

Tolerance (%)
F = ±1 G = ±2 J = ±5

EIA Resistance Value
Standard decade values

Series Size
CRL05 = 0402 CRL12 = 2010
CRL16 = 0603 CRL01 = 2512
CRL10 = 0805 CR12S = 0612
CRL18 = 1206 CR1S = 3720
CRL14 = 1210 CRL02 = 7520

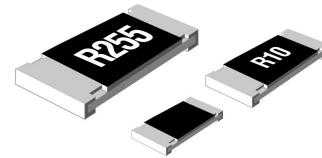

FEATURES

- Current Sensing Resistor
- Reference Standard = IEC 60115-8, JIS C 5201-8

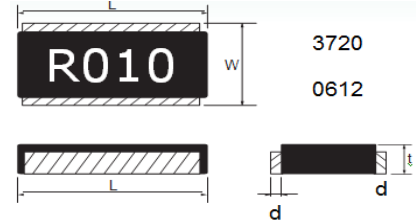
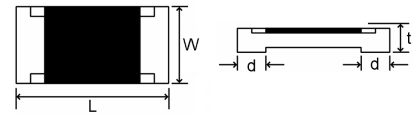

DERATING CURVE

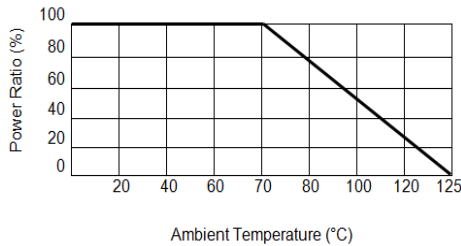

DIMENSIONS (mm)

Size	L	W	D1	D2	Tt
0402	1.00 ± 0.05	0.50 ± 0.05	0.25 ± 0.10	0.20 ± 0.10	0.32 ± 0.05
0603	1.60 ± 0.10	0.80 ± 0.10	0.30 ± 0.20	0.30 ± 0.20	0.45 ± 0.10
0805	2.00 ± 0.15	1.25 ± 0.15	0.30 ± 0.20	0.30 ± 0.20	0.50 ± 0.10
1206	3.10 ± 0.15	1.55 ± 0.15	0.50 ± 0.30	0.40 ± 0.20	0.60 ± 0.10
2010	5.00 ± 0.15	2.50 ± 0.15	0.60 ± 0.30	0.50 ± 0.25	0.60 ± 0.10
2512	6.30 ± 0.15	3.10 ± 0.15	0.60 ± 0.30	0.50 ± 0.25	0.60 ± 0.10
3720	3.75 ± 0.20	2.00 ± 0.20	0.40 ± 0.20	0.40 ± 0.20	0.60 ± 0.10
0612	7.50 ± 0.20	2.00 ± 0.20	0.40 ± 0.20	0.40 ± 0.20	0.60 ± 0.10

RATING & CHARACTERISTIC

Size	Tolerance (%)	Max TCR (ppm/°C) Per Resistance Range in Ω					Rated Power	Operating Voltage V = √(P/R)	Operating Current I = √(P/R)	Operating Temp. Range is -55°C ~ +125°C
		±300	±250	±200	±150	±100				
0402	±1, ±2, ±5	0.100 ~ 0.200	0.220 ~ 1.000				1/16 W			
0603	±1, ±2, ±5	0.100 ~ 0.910		0.010 ~ 0.200		0.021 ~ 0.910	1/10 W			
0805	±1, ±2, ±5		0.100 ~ 0.910	0.010 ~ 0.091	0.100 ~ 0.200	0.005 ~ 0.020 0.210 ~ 0.910	1/8 W			
1206	±1, ±2, ±5		0.100 ~ 0.910	0.010 ~ 0.091		0.002 ~ 0.030	1/4 W			
1210	±1, ±2, ±5			0.100 ~ 0.910			1/4 W			
2010	±1, ±2, ±5			0.100 ~ 0.910		0.005 ~ 0.030	1/2 W			
2512	±1, ±2, ±5	0.001 ~ 0.050		0.010 ~ 0.091 0.100 ~ 0.910		0.001 ~ 0.010	1W			
3720	±1, ±2, ±5					0.001 ~ 0.030	0.5W & 1W			
0612	±1, ±2, ±5					0.001 ~ 0.010	0.5W & 1W			

PERFORMANCE

Item	Specification	Test Method
Temp. Coefficient of Resistance	As Spec	MIL-STD-202F, Method 304 304 +25/-55/+25/+125/+25 °C
Short Time Overload	±(0.5% + 0.05Ω)	JIS-C-5202-5.5 RCWV*2.5orMax Overloading Voltage 5 seconds
Dielectric Withstand Voltage	By type	MIL-STD-202F, Method 301 Apply Max Overload Voltage for 1 minute
Insulation Resistance	>1000M Ω	MIL-STD-202F, Method 302 Apply 100VDC for 1 minute
Thermal Shock	±(0.5% + 0.05Ω)	MIL-STD-202F, Method 107G -55 °C ~ + 150 °C, 100 cycles
Load Life	±(1% + 0.05Ω)	MIL-STD-202F, Method 108A RCWV 70 °C, 1.5 hrs ON, 0.5 hrs off, 1000 ~ 1048 hrs
Humidity (Stable State)	±(1% + 0.05Ω)	MIL-STD-202F, Method 103B 40 °C, 90~95%RH, RCWV 1.5 hrs ON, 0.5 hrs OFF, total 1000 ~ 1048 hrs
Resistance to Dry Heat	±(0.5% + 0.05Ω)	JIS-C-5202 7.2 96 hours @ +125 °C without load
Low Temperature Operation	±(0.5% + 0.05Ω)	JIS-C-5202 7.1 1 hour, -65 °C followed by 45 minutes if RCWV
Bending Strength	±(0.5% + 0.05Ω)	JIS-C-5202 6.1.4 Bending Amplitude 3mm for 10 seconds
Solderability	95% min. Coverage	MIL-STD-202F, Method 208H 235 °C±5 °C, 2±0.5 (sec)
Resistance to Soldering Heat	±(0.5% + 0.05Ω)	MIL-STD-202F, Method 210E 260±5 °C, 10±1second

The content of this specification may change without notification 5/15/2015