



Dual Mode Bi-directional Dual Input Laser Driver

Main features: dual control mode, bi-directional output, dual input mode (analog & digital), high precision, high reliability, and small package.

Part number:	DBD-R2V1
Maximum output current on LDA and LDC:	200mA
Output voltage range on LDA:	0.8V — 8V
Output voltage range on LDC:	-0.8V — -8V
Laser current and power control accuracy:	14bit
Laser current control resolution:	48.8 μ A/step
Laser power control resolution:	0.024%/step
Laser current & power digital control signal:	TTL, serial
Laser current set-point voltage:	0 to 2.5V
Laser power set-point voltage:	0 to 2.5V
Laser current and power indication voltage:	0 to 2.5V
Laser current indication absolute accuracy:	\pm 0.2%
Current output noise:	0.1% RMS
Soft-start rise time:	0.1 S
Power input DC voltage:	4.75V to 5.25V
Operation mode:	CC (Constant Current) and CP (Constant Power)
Operating temperature:	-20°C to +85°C
Module dimension:	25.5mm \times 20 mm \times 4.5mm

Pin Descriptions

- Pin 1** **SD**, shut down, digital input, positive logic, $>2.3V$ = shut down, $<0.5V$ = enable, normal threshold voltage = 1V. The input current is between $-1\mu A$ and $1\mu A$. It is pulled down by a 20K resistor to ground.
- Pin 2** **CLGD**, control loop good indication, digital output. The maximum output current is 10mA. A HI level indicates control loop locked.
- Pin 3** **GND**, signal ground pin. Connect ADC and DAC grounds to here.
- Pin 4** **2.5V**, reference voltage, analog output. It is used by the internal DACs as the reference voltage. It can source and sink 5mA current with a maximum 20ppm/ $^{\circ}C$ stability max.
- Pin 5** **LIS**, laser current set-point voltage, analog input. 0V to 2.5V sets the output current from 0 to 200mA linearly. The input impedance of this pin is 20K Ω . This pin can be set by an external analog signal source, such as the output of a closed-loop op-amp, POT, or DAC, or set by the internal DAC B and leave LPS pin unconnected. The internal DAC is connected to the reference voltage 2.5V, so that its full scale is 2.5V.



- Pin 6** LIO, laser current output indication, analog output. 0V to 2.5V indicates the laser current of from 0 to 200mA linearly.
- Pin 7** LPS, laser power set-point voltage, analog input. 0V to 2.5V sets the laser output power from 0 to the maximum value linearly. The input impedance of this pin is 20KΩ. This pin can be set by an external analog signal source, such as the output of a closed-loop op-amp, POT, or DAC, or set by the internal DAC A and leave this LPS pin unconnected. The internal DAC is connected to the reference voltage 2.5V, so that its full scale is 2.5V.
- Pin 8** LPI, laser power feedback input, analog input. High impedance input. The (positive-going) output of an external power sense photodiode amplifier should be connected to this pin. Maximum power for a given laser diode should correspond to 2.5 V.
- Pin 9** LDA, laser diode anode, analog output. This pin is used to drive a laser of which the cathode is connected to the case and the case is connected to the ground. When using this pin, the laser anode needs to be connected to the ground. See Figure 1A.
- Pin 10** LDC, laser diode cathode, analog output. This pin is used to drive a laser of which the anode is connected to the case and the case is connected to the ground. When using this pin, the laser cathode needs to be connected to the ground. See Figure 1B.
- Pin 11** GND, ground. Connect laser anode or cathode to here.
- Pin 12** GND, ground. Connect power supply return rail to here.
- Pin 13** VPS, power supply, analog power input. The driver works at 5.0V.
- Pin 14** SCK, serial interface clock, high impedance digital input. See Linear Tech LTC1654 data sheet.
- Pin 15** SDI/MIND, serial data input/mode indication, digital input and output. The input impedance is 20KΩ. When used as an output, a HI (=VPS) indicates constant current mode operation and a LO (=GND) indicates constant power mode. When used as an input, is the data input to the serial interface DACs. See Linear Tech LTC1654 data sheet.
- Pin 16** CSLD, control/serial port/load, high impedance digital input. This pin is the DACs' input for serial interface enable and load control. See Linear Tech LTC1654 data sheet.

Mode Setting

A. Set the driver to constant current mode without over power protection

Under this mode, the laser is always operating at constant current mode.

1. Set $LIS = 2.5V \times I_{laser} \div 200mA$, where I_{laser} is the set-point laser current. LIS can be set by the way described in the pin description section.
2. Set LPS to 2.5V reference and connect LPI pin to ground. LPS can be set by the way described in the pin description section.

B. Set the driver to constant current mode with over power protection

Under this mode, the laser is operating at the constant current mode unless the laser output power reaches the preset maximum power. When the laser output power reaches the protection power, the laser will be operating at a constant power mode.



1. Set $LIS = 2.5V \times I_{set} \div 200mA$, where I_{laser} is a laser set-point current. LIS can be set by the way described in the pin description section.
2. Set LPS to a voltage value which will be generated at the LPI pin by the external TIA (Trans-Impedance Amplifier) when the laser is outputting the protection power. The TIA converts the current of the PD (Photo Diode) into a voltage which is fed into the LPI pin. The PD current is generated by the laser. LPS can be set by the way described in the pin description section. Make sure that the set-point laser current is at least 5% less than the current needed to generate the maximum laser power.

C. Set the driver to constant power mode without over current protection

Under this mode, the laser is operating at the constant power mode unless the laser current reaches 200mA. When the laser output power reaches 200mA, the laser will be operating at a constant current mode.

1. Connect LIS to 2.5V reference pin, or set LIS by the way described in the pin description section.
2. Set LPS to a voltage value which will be generated at the LPI pin by the external TIA (Trans-Impedance Amplifier) when the laser is outputting the set-point power. The TIA converts the current of the PD (Photo Diode) into a voltage which is fed into the LPI pin. The PD current is generated by the laser. LPS can be set by the way described in the pin description section. Make sure that the laser can output the set-point power by a current of less than 190mA.

D. Set the driver to constant power mode with over current protection

Under this mode, the laser is operating at the constant power mode unless the laser current reaches a predetermined protection current. When the laser reaches the protection current, the laser will be operating at a constant current mode.

1. Set $LIS = 2.5V \times I_{protect} \div 200mA$, where $I_{protect}$ is predetermined protection current. LIS can be set by the way described in the pin description section.
2. Set LPS to a voltage value which will be generated at the LPI pin by the external TIA (Trans-Impedance Amplifier) when the laser is outputting the set-point power. The TIA converts the current of the PD (Photo Diode) into a voltage which is fed into the LPI pin. The PD current is generated by the laser. LPS can be set by the way described in the pin description section. Make sure that the laser can output the set-point power by a current of less than 95% of the protection current.

Mounting the High Precision Digital Input Laser Driver on PCB's

The high precision digital input laser drivers come in two types of packages: surface mount and through hole. **The surface mount package has to be soldered manually, not by reflow oven.** The through hole package can be mounted through a socket, soldered manually, or by wave soldering machine.

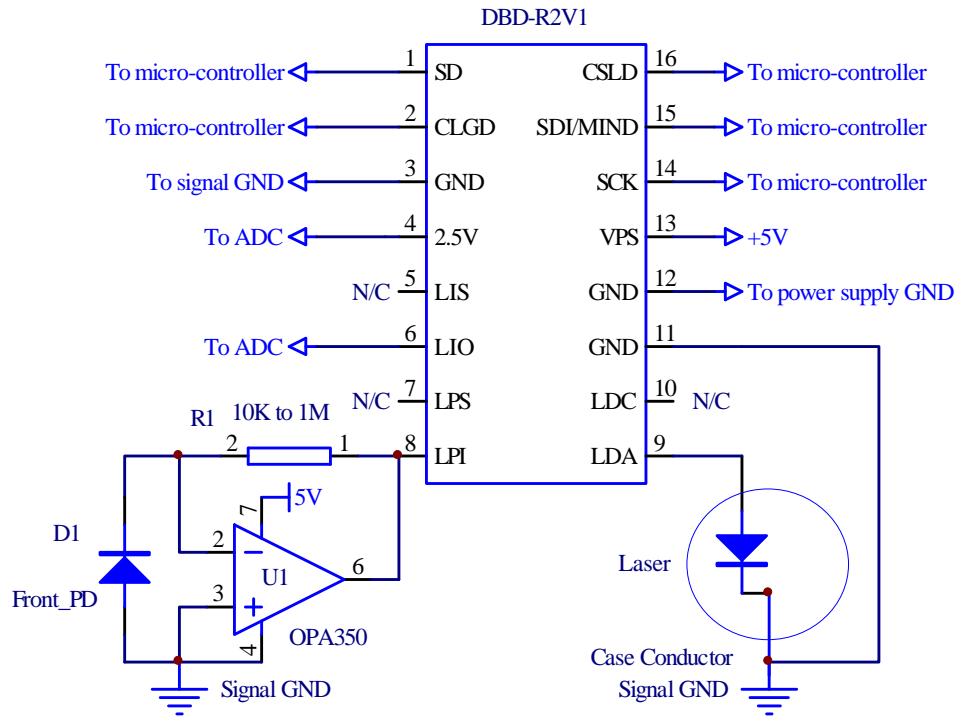

Figure 1A Driving a Common Cathode Laser

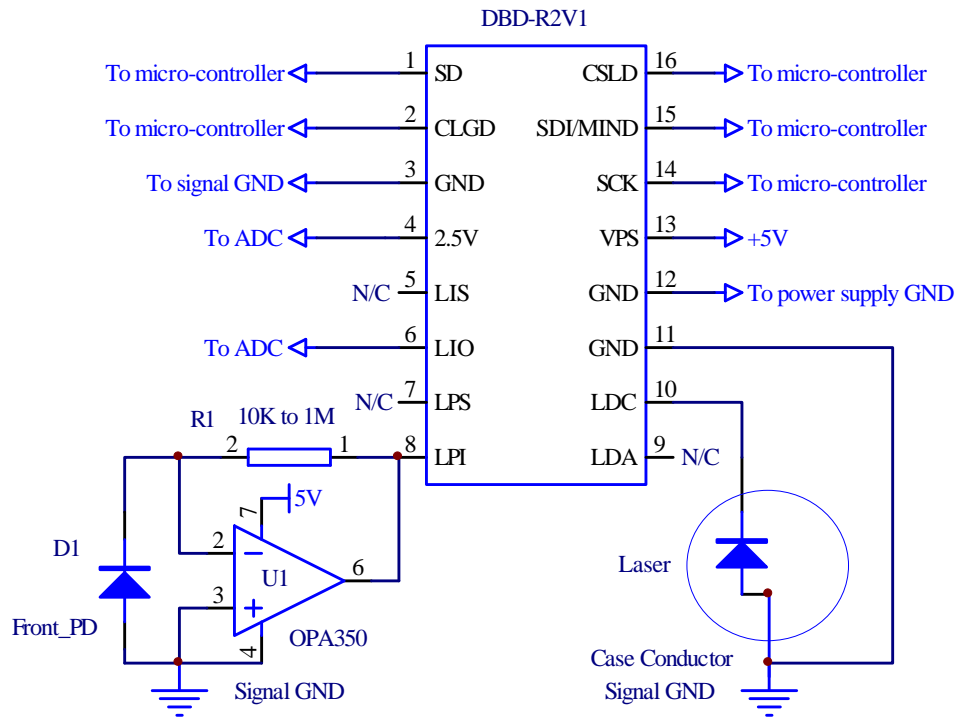

Figure 1B Driving a Common Anode Laser



Mechanical dimensions

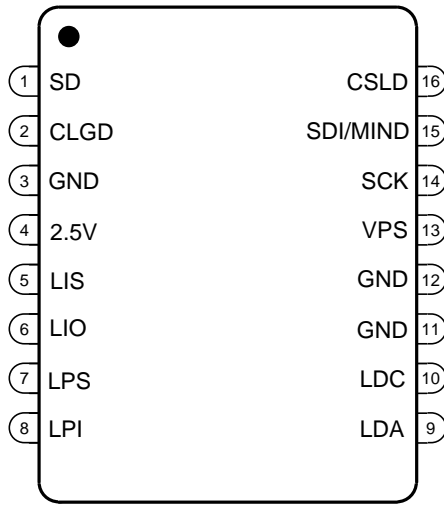

Figure 2 Top View of DBD-R2V1-S

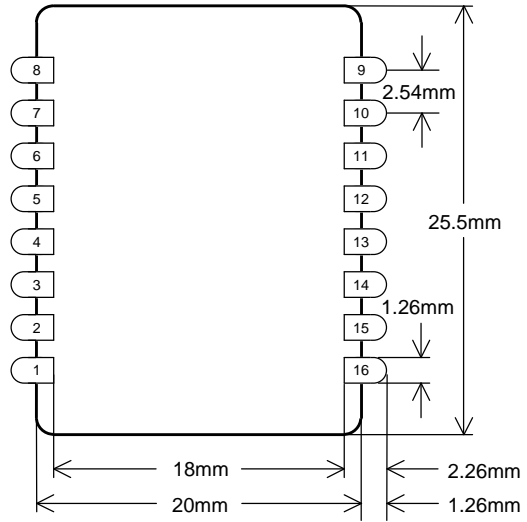

Figure 3 Bottom View of DBD-R2V1-S

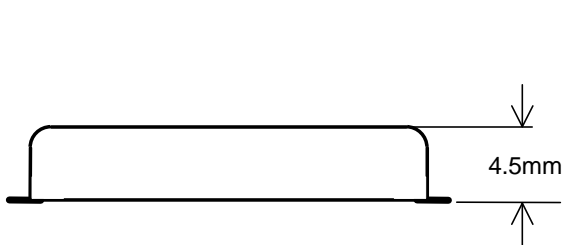

Figure 4 End View of DBD-R2V1-S

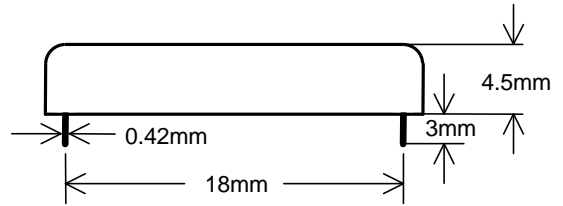

Figure 5 End View of DBD-R2V1-D

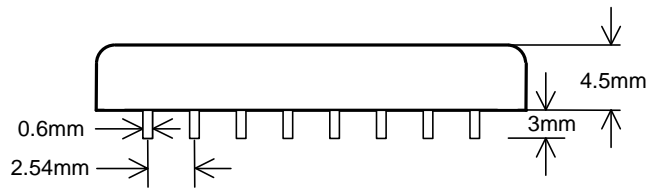

Figure 6 Side View of DBD-R2V1-D

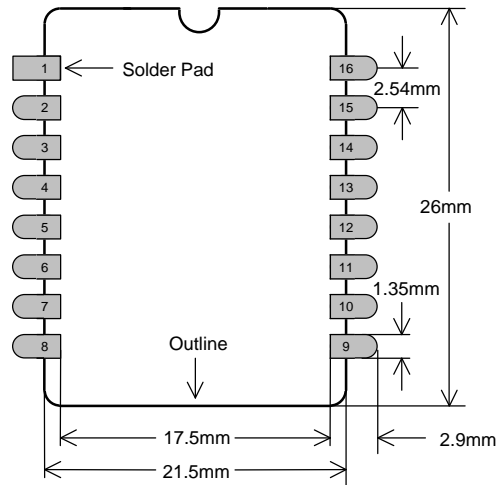

Figure 7 Recommended PCB Footprint for Surface Mount Package

Ordering Guide

Part Number	Description	Note
DBD-R2V1-D	High precision input laser driver	DIP package
DBD-R2V1-S	High precision input laser driver	SMT package