

PANEL CUTOUT

PANEL THICKNESS	(X) DIMENSION
0.75 - 1.25	19.2
1.25 - 2.00	19.4
2.00 - 3.00	19.6

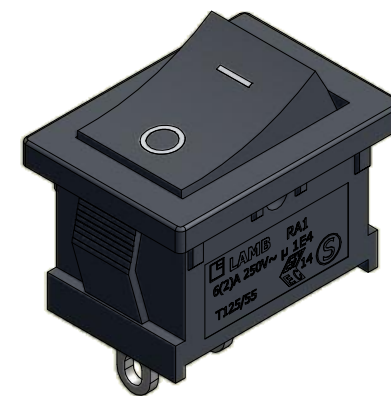

SWITCH FUNCTION	
POS. 1	POS. 2
OFF	ON
OPEN	1-1a

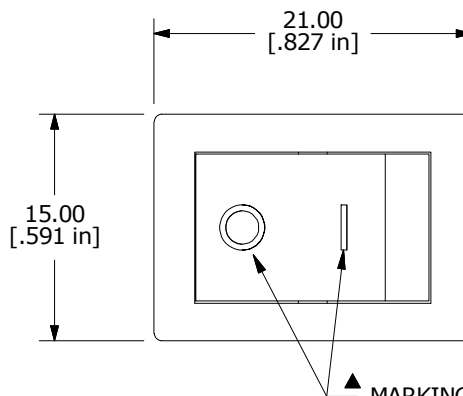
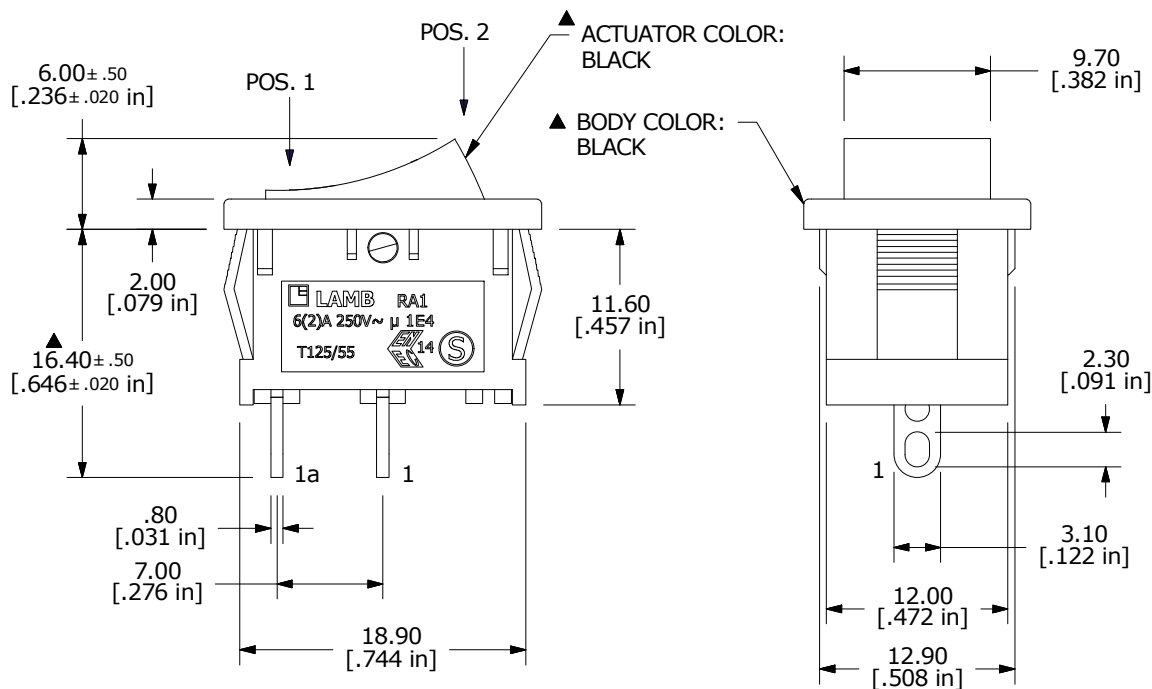
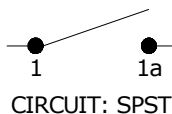

NOTE:

- DIMENSIONS IN MM [INCH]
- GENERAL TOLERANCE: X.X = ± 0.4
X.XX = ± 0.25
- TERMINAL NUMBERS FOR REF ONLY
- CONTACT MATERIAL: SILVER
- CONTACT RATINGS: UR, cUR
10A @ 125VAC / 250VAC
EN 61058-1:2002
6A 250V, 1E4, T85
6(2)A 250V, 1E4, T125/55
10(4)A 250V, 1E4, T125/55
10(2)A 250V, 5E4, T85/55
- CONTACT RESISTANCE: 35mΩ MAX. @ 50VAC
- INSULATION RESISTANCE: 100MΩ MIN. @ 500VAC
- DIELECTRIC STRENGTH: 1,500VAC FOR 1 MINUTE
- ▲ DENOTES CRITICAL PARAMETER
- 2002/95/EC (ROHS) COMPLIANT



TITLE RA1213112R

A	21821	INITIAL RELEASE	4/7/15	MW
REV	PCR NO	DESCRIPTION	DATE	BY

THE INFORMATION CONTAINED IN THIS DOCUMENT IS PROPRIETARY TO E-SWITCH AND IS NOT TO BE COPIED OR TRANSFERRED

DATE	DR	DWG	REV
4/7/2015	MW	38-RA1213112R	A