

10 Bit, 40MHz
Current -Output DACs

FEATURES

- +2.7V to +3.3V Single-Supply Operation
- Wide Spurious-Free Dynamic Range: 70dB at $f_{OUT} = 2.2\text{MHz}$
- Fully Differential Output
- Low-Current Standby or Full Shutdown Modes
- Internal +1.2V, Low-Noise Bandgap Reference
- Small 24-Pin Flat-pack Package

OPTIONS

- **Package(s)**
24-Pin Flat-pack

- **Operating Temperature Ranges**

- Extended Temperature (-55°C to +125°C)
- Industrial Temperature (-40°C to +85°C)
- Military Processing (-55°C to +125°C)
- Space Processing (-55°C to +125°C)

MARKING

- F
- XT
- IT
- MIL
- SPACE

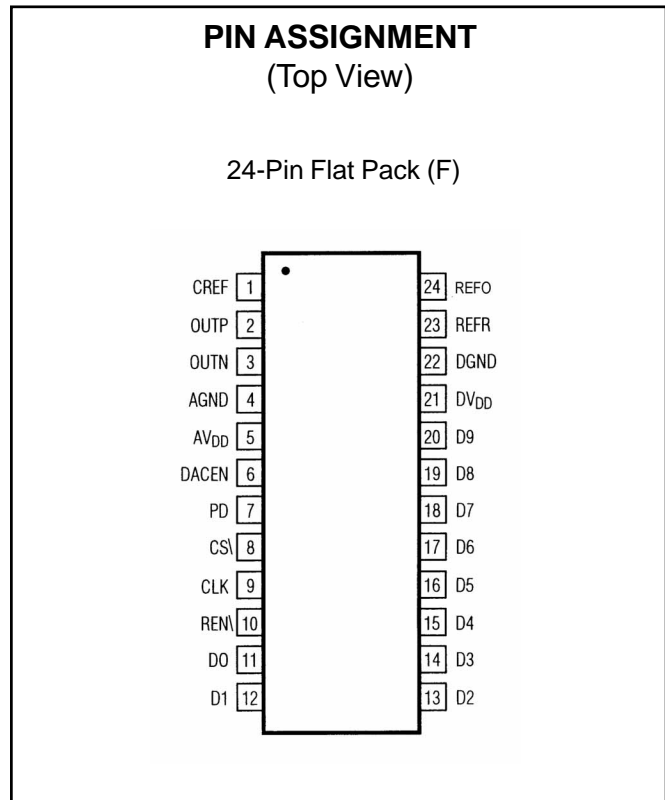

GENERAL DESCRIPTION

The AS5181 is a 10-bit, current-output digital-to-analog converter (DAC) designed for superior performance in signal reconstruction or arbitrary waveform generation applications requiring analog signal reconstruction with low distortion and low-power operation. The AS5181 are designed for a 10pVs glitch operation to minimize unwanted spurious signal components at the output. An on-board 1.2V bandgap circuit provides a well-regulated, low-noise reference that can be disabled for external reference operation.

The devices are designed to provide a high level of signal integrity for the least amount of power dissipation. They operate from a single 2.7V to 3.3V supply. Additionally, these DACs have three modes of operation: normal, low-power standby, and full shutdown, which provides the lowest possible power dissipation with a 1µA (max) shutdown current. A fast wake-up time (0.5µs) from standby mode to full DAC operation facilitates power conservation by activating the DAC only when required.

**For more products and information
please visit our web site at
www.austinsemiconductor.com**



ABSOLUTE MAXIMUM RATINGS*

AV_{DD}, DV_{DD} to AGND, DGND.....-0.3V to +6V
 Digital Inputs to DGND.....-0.3V to +6V
 OUTP, OUTN, CREF to AGND.....-0.3V to +6V
 V_{REF} to AGND.....-0.3V to +6V
 AGND to DGND.....-0.3V to +0.3V
 AV_{DD} to DV_{DD}.....±3.3V
 Maximum Current to Any Pin.....50mA
 Continuous Power Dissipation (TA = +70°C)
 24-Pin Flatpack (derate 9.5mW/°C above +70°C)762mW
 Storage Temperature Range-65°C to +150°C

Lead Temperature (soldering, 10s)+300°C

*Stresses at or greater than those listed under "Absolute Maximum Ratings" may cause permanent damage to the device. This is a stress rating only and functional operation of the device at these or any other conditions above those indicated in the operation section of this specification is not implied. Exposure to absolute maximum rating conditions for extended periods will affect reliability.

ELECTRICAL CHARACTERISTICS (AV_{DD} = DV_{DD} = +3V ±10%, AGND = DGND = 0, f_{CLK} = 40MHz, I_{FS} = 1mA, 400Ω differential output, C_L = 5pF, T_A = T_{MIN} to T_{MAX}, unless otherwise noted. Typical values are at T_A = +25°C.)

PARAMETER	CONDITION	SYM	MIN	TYP	MAX	UNITS
STATIC PERFORMANCE						
Resolution		N	10			Bits
Integral Nonlinearity		INL	-2	±0.5	+2	LSB
Differential Nonlinearity	Guaranteed monotonic	DNL	-1	±0.5	1	LSB
Zero-Scale Error			-2		+2	LSB
Full-Scale Error			-40	±15	+40	LSB
DYNAMIC PERFORMANCE						
Output Settling Time	To ±0.5LSB error band			25		ns
Glitch Impulse				10		pVs
Spurious-Free Dynamic Range to Nyquist	f _{CLK} = 40MHz	f _{OUT} = 550kHz T _A = +25°C	SFDR		72	dBc
				f _{OUT} = 2.2MHz	57	
Total Harmonic Distortion to Nyquist	f _{CLK} = 40MHz	f _{OUT} = 550kHz T _A = +25°C	THD		-70	dB
				f _{OUT} = 2.2MHz	-68	
Signal-to-Noise Ratio to Nyquist	f _{CLK} = 40MHz	f _{OUT} = 550kHz T _A = +25°C	SNR		61	dB
				f _{OUT} = 2.2MHz	56	
Clock and Data Feedthrough	All 0s to all 1s			50		nVs
Output Noise				10		pA/Hz
ANALOG OUTPUT						
Full-Scale Output Voltage		V _{FS}		400		mV
Voltage Compliance of Output			-0.3		0.8	V
Output Leakage Current	DACEN = 0		-1		1	µA
Full-Scale Output Current		I _{FS}	0.5	1	1.5	mA
DAC External Output Resistor Load		R _L		400		Ω

(continued)



ELECTRICAL CHARACTERISTICS ($AV_{DD} = DV_{DD} = +3V \pm 10\%$, $AGND = DGND = 0$, $f_{CLK} = 40MHz$, $I_{FS} = 1mA$, 400Ω differential output, $C_L = 5pF$, $T_A = T_{MIN}$ to T_{MAX} , unless otherwise noted. Typical values are at $T_A = +25^\circ C$.) (continued)

PARAMETER	CONDITION	SYM	MIN	TYP	MAX	UNITS
REFERENCE						
Output Voltage Range		V_{REF}	1.12	1.2	1.28	V
Output Voltage Temperature Drift		TCV_{REF}		50		ppm/ $^\circ C$
Reference Output Drive Capability		I_{REFOUT}		10		μA
Reference Supply Rejection				0.5		mV/V
Current Gain (I_{FS}/I_{REF})				8		mA/mA
POWER REQUIREMENT						
Analog Power-Supply Voltage		AV_{DD}	2.7		3.3	V
Analog Supply Current	PD = 0, DACEN = 1, digital inputs at 0 or DV_{DD}	I_{AVDD}		1.7	4.0	mA
Digital Power-Supply Voltage		DV_{DD}	2.7		3.3	V
Digital Supply Current	PD = 0, DACEN = 1, digital inputs at 0 or DV_{DD}	I_{DVDD}		4.2	5.0	mA
Standby Current	PD = 0, DACEN = 1, digital inputs at 0 or DV_{DD}	$I_{STANDBY}$		1	1.5	mA
Shutdown Current	PD = 1, DACEN = X, digital inputs at 0 or DV_{DD} (X = don't care)	I_{SHDN}		0.5	1	μA
LOGIC INPUTS AND OUTPUT						
Digital Input Voltage High		V_{IH}	2			V
Digital Input Voltage Low		V_{IL}			0.8	V
Digital Input Current	$V_{IN} = 0$ or DV_{DD}	I_{IN}			± 1	μA
Digital Input Capacitance		C_{IN}		10		pF
TIMING CHARACTERISTIC						
DAC DATA to CLK Rise Setup Time		t_{DS}	10			ns
DAC CLK Rise to DATA Hold Time		t_{DH}	0			ns
CS\ Fall to CLK Rise Time				5		ns
CS\ Fall to CLK Fall Time				5		ns
DACEN Rise Time to V_{OUT}				0.5		μs
PD Fall Time to V_{OUT}				50		μs
Clock Period		t_{CLK}	25			ns
Clock High Time		t_{CH}	10			ns
Clock Low Time		t_{CL}	10			ns

TYPICAL OPERATING CHARACTERISTICS (AV_{DD} = DV_{DD} = +3V, AGND = DGND = 0, I_{FS} = 1mA, 400Ω differential output, C_L = 5pF, T_A = +25°C, unless otherwise noted.)

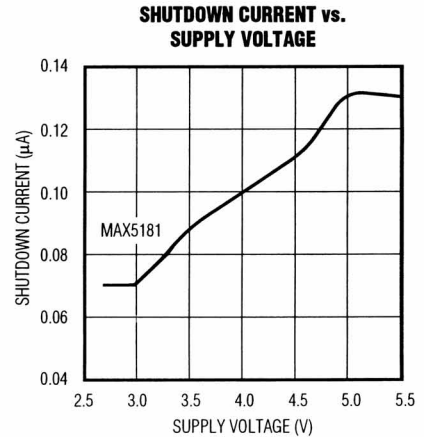
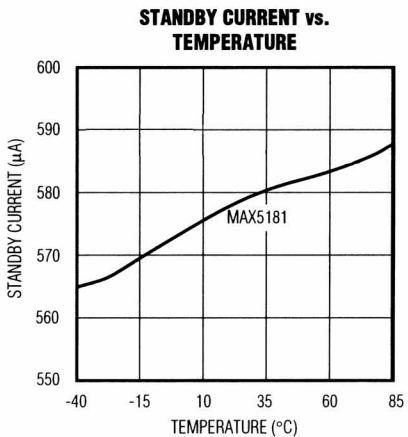
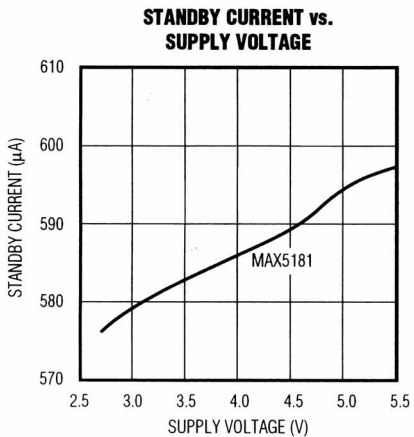
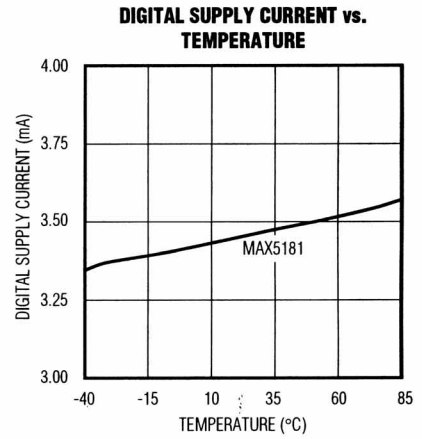
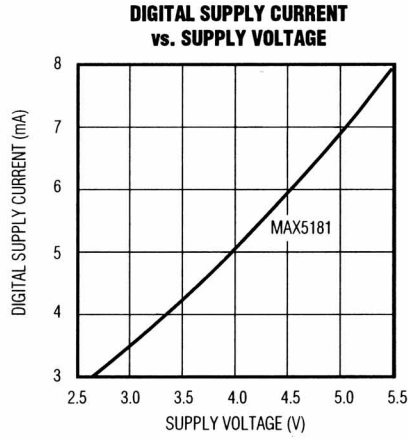
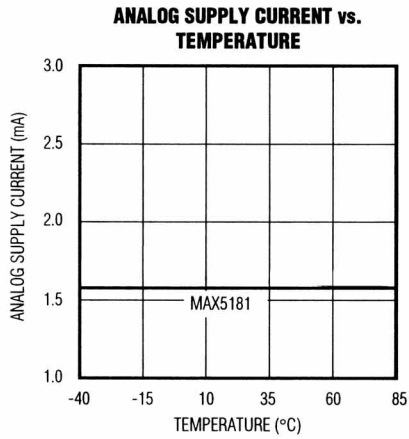
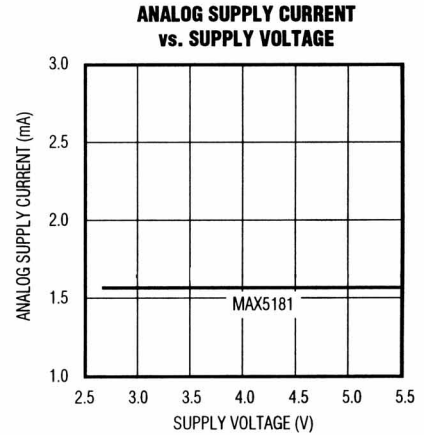
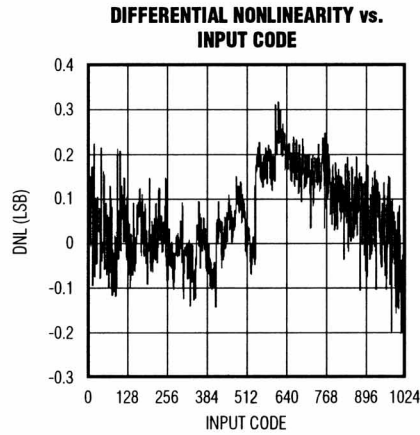
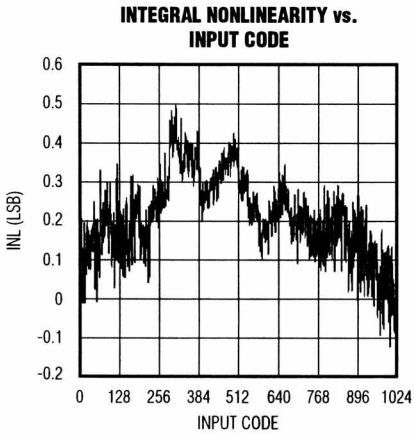

TYPICAL OPERATING CHARACTERISTICS ($AV_{DD} = DV_{DD} = +3V$, $AGND = DGND = 0$, $I_{FS} = 1mA$, 400Ω differential output, $C_L = 5pF$, $T_A = +25^\circ C$, unless otherwise noted.) (continued)

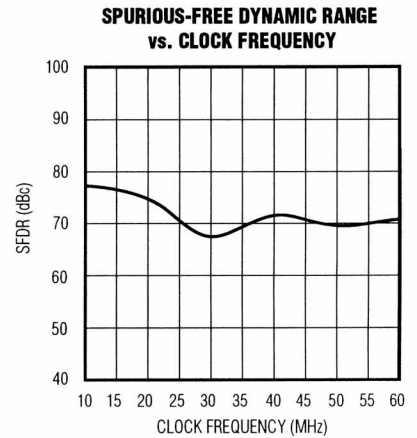
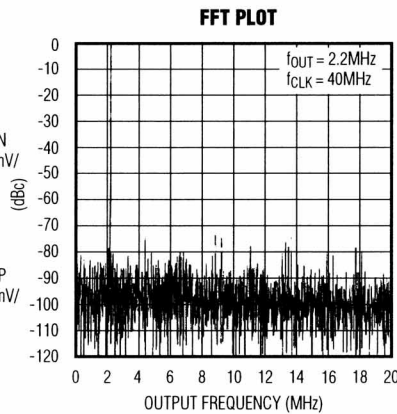
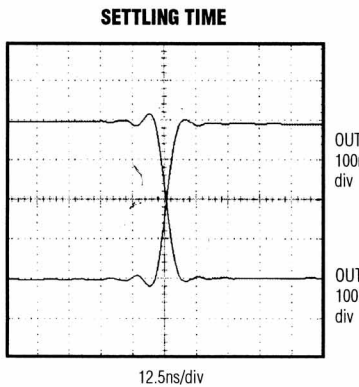
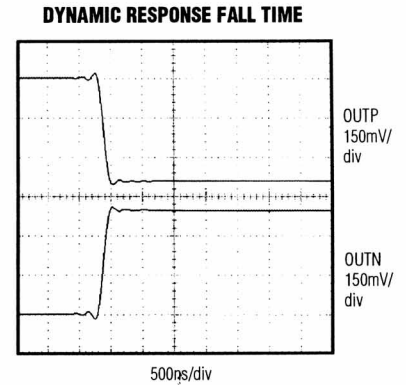
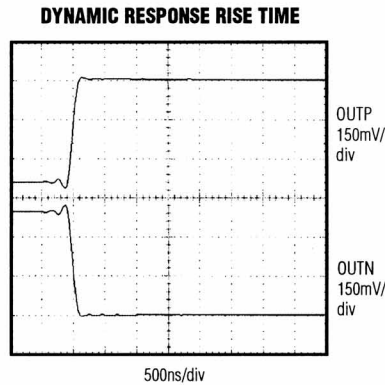
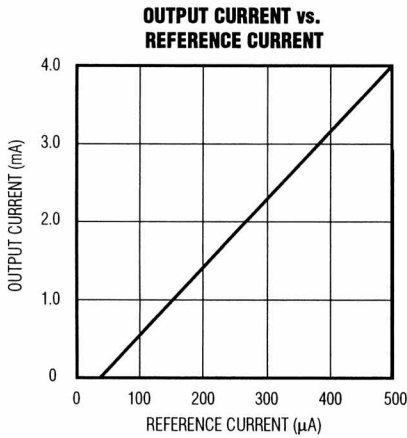
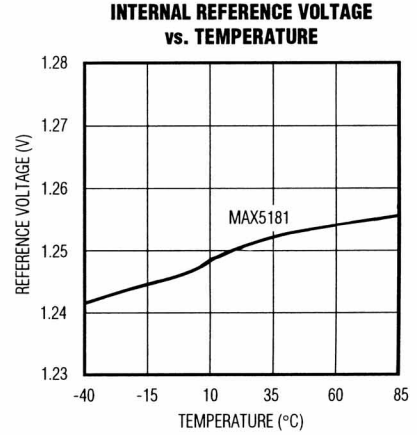
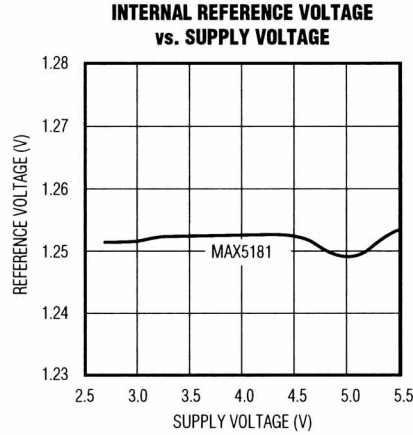
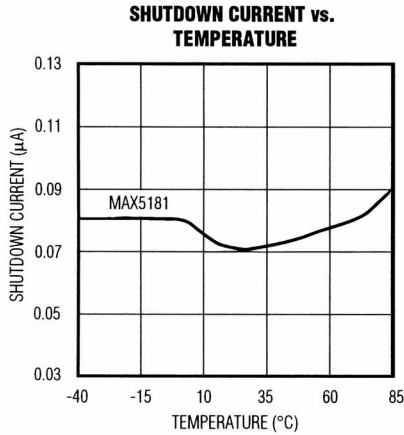

TYPICAL OPERATING CHARACTERISTICS ($AV_{DD} = DV_{DD} = +3V$, $AGND = DGND = 0$, $I_{FS} = 1mA$, 400Ω differential output, $C_L = 5pF$, $T_A = +25^\circ C$, unless otherwise noted.) (continued)

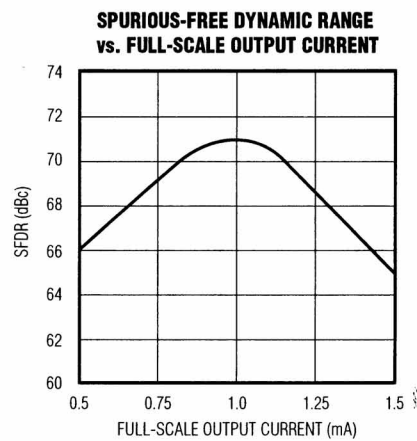
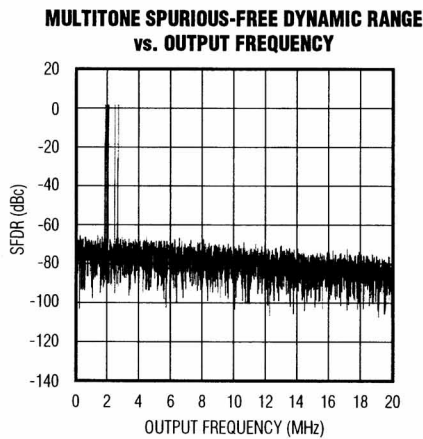
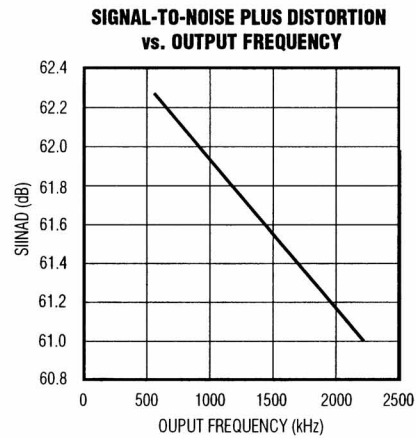
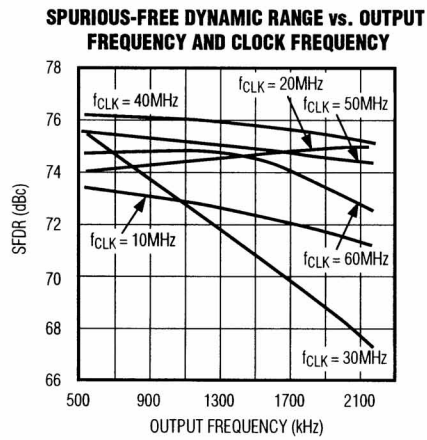

PIN DESCRIPTION

PIN	NAME	FUNCTION
1	CREF	REFO
2	OUTP	Positive Analog Output, Current Output
3	OUTN	Negative Analog Output, Current Output
4	AGND	Analog Ground
5	AV _{DD}	Analog Positive Supply, +2.7V to +3.3V
6	DACEN	DAC Enable, Digital Input 0: Enter DAC standby mode with PD = DGND 1: Power-up DAC with PD = DGND X: Enter shutdown mode with PD = DV _{DD} (X = Don't Care)
7	PD	Power-Down Select 0: Enter DAC standby mode (DACEN = DGND) or power-up DAC (DACEN = DV _{DD}) 1: Enter shutdown mode
8	CS\	Active-Low Chip Select
9	CLK	Clock Input
10	REN\	Active-Low Reference Enable. Connect to DGND to activate on-chip +1.2V reference.
11	D0	Data Bit D0 (LSB)
12 - 19	D1 - D8	Data Bits D1 - D8
20	D9	Data Bit D9 (MSB)
21	DV _{DD}	Digital Supply, +2.7V to +3.3V
22	DGND	Digital Ground
23	REFR	Reference Input
24	REFO	Reference Output

DETAILED DESCRIPTION

The AS5181 is a 10-bit digital-to-analog converters (DACs) capable of operating with clock speeds up to 40MHz. Each converter consists of separate input and DAC registers, followed by a current source array capable of generating up to 1.5mA full-scale output current (Figure 1). An integrated 1.2V voltage reference and control amplifier determine the data converters' full-scale output currents/voltages. Careful reference design ensures close gain matching and excellent drift characteristics.

Internal Reference and Control Amplifier

The AS5181 provide an integrated 50ppm/°C, 1.2V, low-noise bandgap reference that can be disabled and overridden by an external reference voltage. REFO serves either as an external reference input or an integrated reference output. If REN\ is connected to DGND, the internal reference is

selected and provides a +1.2V output. Due to its limited 10µA output drive capability, REFO must be buffered with an external amplifier, if heavier loading is required.

The AS5181 also employ a control amplifier designed to regulate simultaneously the full-scale output current (I_{FS}) for both outputs of the devices. The output current is calculated as follows:

$$I_{FS} = 8 \cdot I_{REF}$$

where I_{REF} is the reference output current ($I_{REF} = V_{REFO}/R_{SET}$) and I_{FS} is the full-scale output current. R_{SET} is the reference resistor that determines the amplifier's output current on the AS5181 (Figure 2). This current is mirrored into the current source array, where it is equally distributed between matched current segments and summed to valid output current readings for the DACs.

FIGURE 1: Functional Diagram

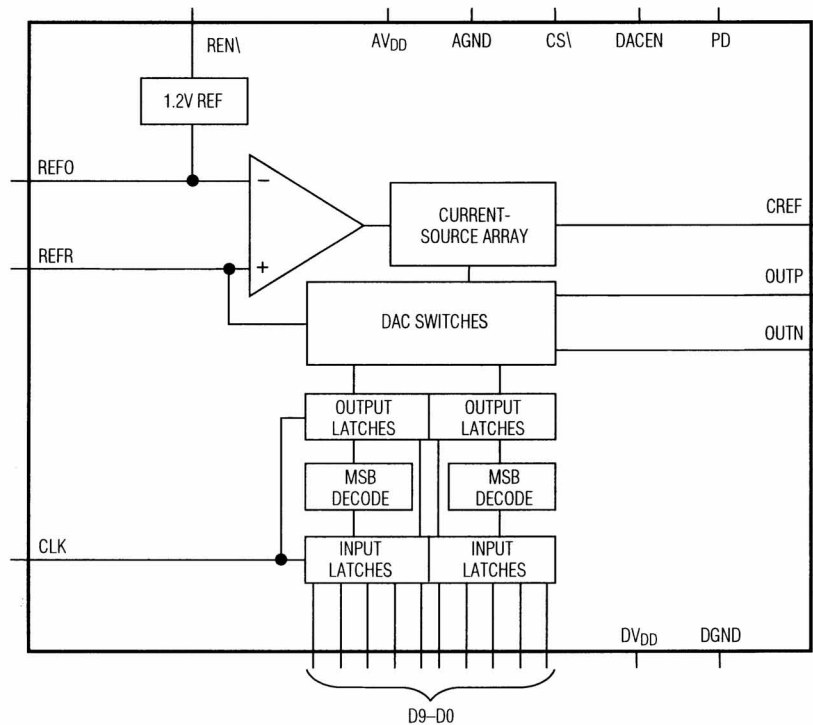

External Reference

To disable the AS5181 internal reference, connect REN\ to DV_{DD}. A temperature-stable, external reference may now be applied to drive the REFO pin to set the full-scale output (Figure 3). Choose a reference capable of supplying at least 150μA to drive the bias circuit that generates the cascode current for the current array. For improved accuracy and drift performance, choose a fixed output voltage reference.

Standby Mode

To enter the lower-power standby mode, connect digital inputs PD and DACEN to DGND. In standby, both the reference and the control amplifier are active with the current array inactive. To exit this condition, DACEN must be pulled high with PD held at DGND. The AS5181 typically require 50μs to wake up and let both outputs and the reference settle.

Shutdown Mode

For lowest power consumption, the AS5181 provide a power-down mode in which the reference, control amplifier,

and current array are inactive and the DAC supply current is reduced to 1μA. To enter this mode, connect PD to DV_{DD}. To return to active mode, connect PD to DGND and DACEN to DV_{DD}. About 50μs are required for the parts to leave shutdown mode and settle to their outputs’ values prior to shutdown. The “Power-Down Mode Selection” table lists the power-down mode selection.

Timing Information

Figure 4 shows a detailed timing diagram for the AS5181. With each high transition of the clock, the input latch is loaded with the digital value set by bits D9 through D0. The content of the input latch is then shifted to the DAC register, and the output updates at the rising edge of the next clock.

Outputs

The AS5181 output is designed to supply full-scale output currents of 1mA into 400Ω loads in parallel with a capacitive load of 5pF.

FIGURE 2: Setting I_{FS} with the Internal +1.2V Reference and the Control Amplifier

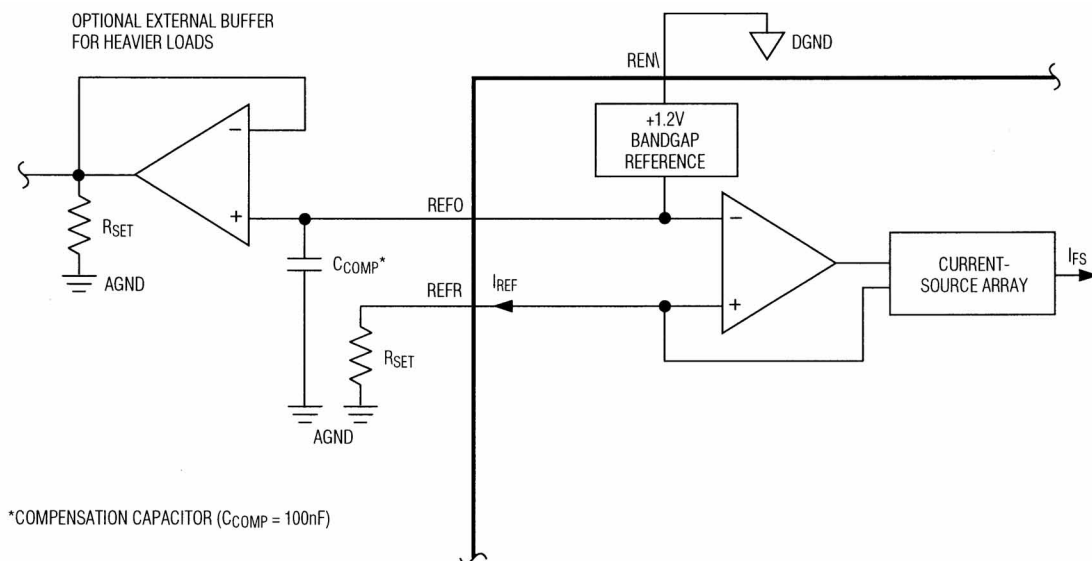

POWER-DOWN MODE SELECTION

PD (POWER-DOWN SELECT)	DACEN (DAC ENABLE)	POWER-DOWN MODE	OUTPUT STATE
0	0	Standby	High-Z
0	1	Wake-Up	Last state prior to standby mode
1	X	Shutdown	High-Z

X = Don't Care

FIGURE 3: AS5181 with External Reference

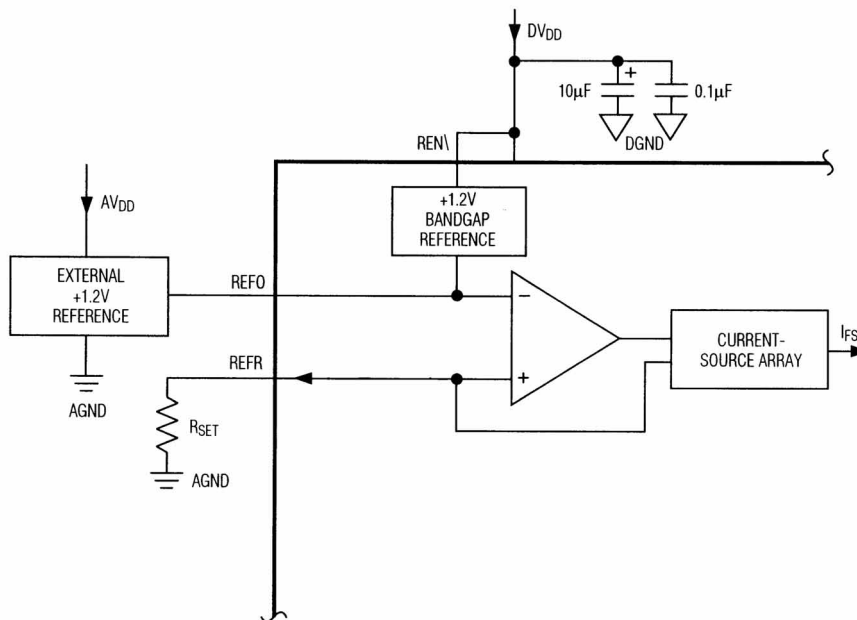

APPLICATIONS INFORMATION

Static and Dynamic Performance Definitions

Integral Nonlinearity

Integral nonlinearity (INL) (Figure 5a) is the deviation of the values on an actual transfer function from either a best-straight-line fit (closest approximation to the actual transfer curve) or a line drawn between the endpoints of the transfer function once offset and gain errors have been nullified. For a DAC, the deviations are measured every single step.

Differential Nonlinearity

Differential nonlinearity (DNL) (Figure 5b) is the difference between an actual step height and the ideal value of 1LSB. A DNL error specification of less than 1LSB guarantees no missing codes and a monotonic transfer function.

Offset Error

Offset error (Figure 5c) is the difference between the ideal and the actual offset point. For a DAC, the offset point is the step value when the digital input is zero. This error affects all codes by the same amount and can usually be compensated by trimming.

Gain Error

Gain error (Figure 5d) is the difference between the ideal and the actual full-scale output voltage on the transfer curve, after nullifying the offset error. This error alters the slope of the transfer function and corresponds to the same percentage error in each step.

Settling Time

Settling time is the amount of time required from the start of a transition until the DAC output settles its new output value to within the converter's specified accuracy.

Digital Feedthrough

Digital feedthrough is the noise generated on a DAC's output when any digital input transitions. Proper board layout and grounding will significantly reduce this noise, but there will always be some feedthrough caused by the DAC itself.

Total Harmonic Distortion

Total harmonic distortion (THD) is the ratio of the RMS sum of the input signal's first four harmonics to the fundamental itself. This is expressed as:

$$THD = 20 \cdot \log \left(\frac{\sqrt{V_2^2 + V_3^2 + V_4^2 + V_5^2}}{V_1} \right)$$

where V1 is the fundamental amplitude, and V2 through V5 are the amplitudes of the 2nd- through 5th-order harmonics.

Spurious-Free Dynamic Range

Spurious-free dynamic range (SFDR) is the ratio of RMS amplitude of the fundamental (maximum signal component) to the RMS value of the next-largest distortion component.

Differential to Single-Ended Conversion

A low-distortion, high-input bandwidth amplifier may be used to generate a voltage from the array current output of the AS5181. The differential voltage across OUTP and OUTN is converted into a single-ended voltage by designing an appropriate operational amplifier configuration (Figure 6).

I/Q Reconstruction in a QAM Application

The low-distortion performance of two AS5181s supports analog reconstruction of in-phase (I) and quadrature (Q) carrier components typically used in quadrature amplitude modulation (QAM) architectures where two separate buses carry the I and Q data. A QAM signal is both amplitude (AM) and phase modulated, created by summing two independently modulated carriers of identical frequency but different phase (90° phase difference).

In a typical QAM application (Figure 7), the modulation occurs in the digital domain, and two DACs such as the AS5181 may be used to reconstruct the analog I and Q components.

The I/Q reconstruction system is completed by a quadrature modulator that combines the reconstructed components with in-phase and quadrature carrier frequencies and then sums both outputs to provide the QAM signal.

FIGURE 4: TIMING DIAGRAM

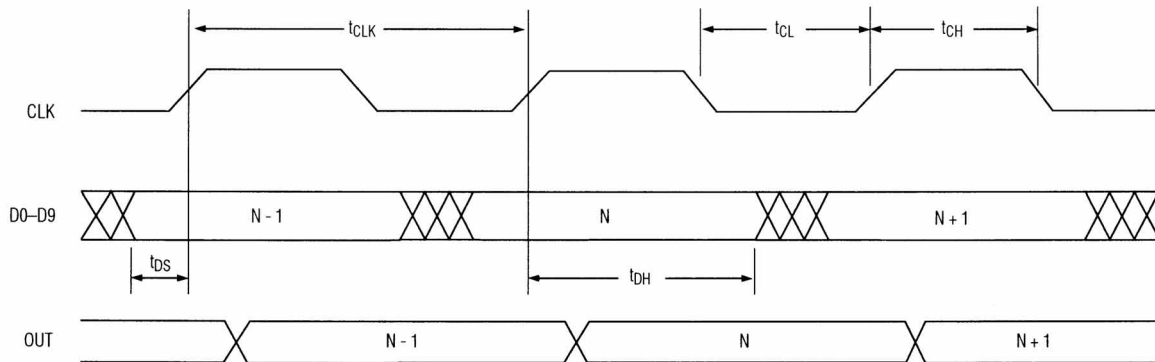

Using the AS5181 for Arbitrary Waveform Generation

Designing a traditional arbitrary waveform generator (AWG) requires five major functional blocks (Figure 8a): clock generator, counter, waveform memory, DAC for waveform reconstruction, and output filter. The waveform memory contains the sequentially stored digital replica of the desired analog waveforms. This memory shares a common clock with the DAC.

For each clock cycle, a counter adds one count to the address for the waveform memory. The memory then loads the next value to the DAC, which generates an analog output voltage corresponding to that data value. A DAC output filter can either be a simple or complex lowpass filter, depending on the AWG requirements for waveform function and frequencies. The main limitations of the AWG's flexibility are DAC

resolution and dynamic performance, memory length, clock frequency, and the filter characteristics.

Although the AS5181 offer high-frequency operation and excellent dynamics, they are suitable for relaxed requirements in resolution (10-bit AWGs). To increase an AWG's high-frequency accuracy, temperature stability, wide-band tuning, and past phase-continuous frequency switching, the user may approach a direct digital synthesis (DDS) AWG (Figure 8b). This DDS loop supports standard waveforms that are repetitive, such as sine, square, TTL, and triangular waveforms. DDS allows for precise control of the data-stream input to the DAC. Data for one complete output waveform cycle is sequentially stored in a RAM. As the RAM addresses are changing, the DAC converts the incoming data bits into a corresponding voltage waveform. The resulting output signal frequency is proportional to the frequency rate at which the RAM addresses are changed.

FIGURES 5 A thru D

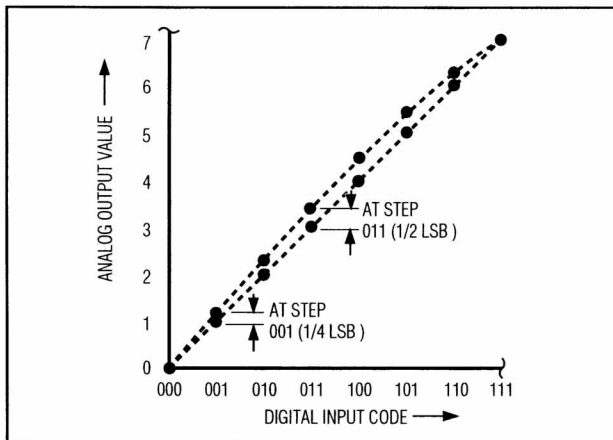

Figure 5a. Integral Nonlinearity

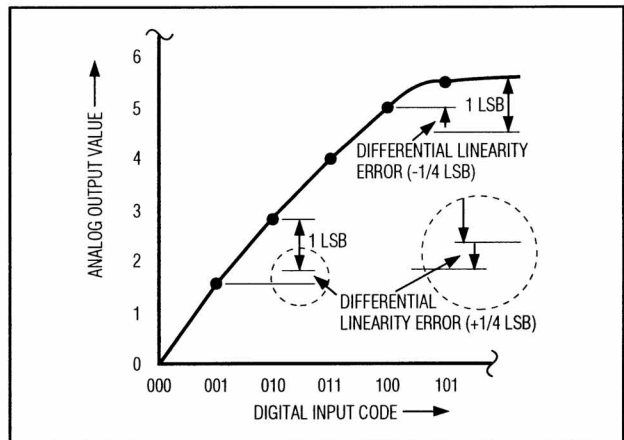

Figure 5b. Differential Nonlinearity

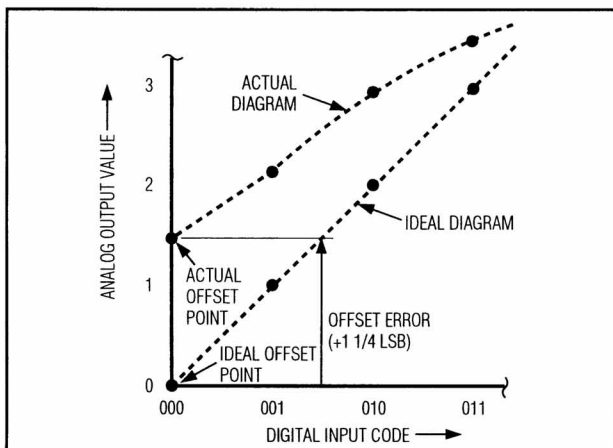

Figure 5c. Offset Error

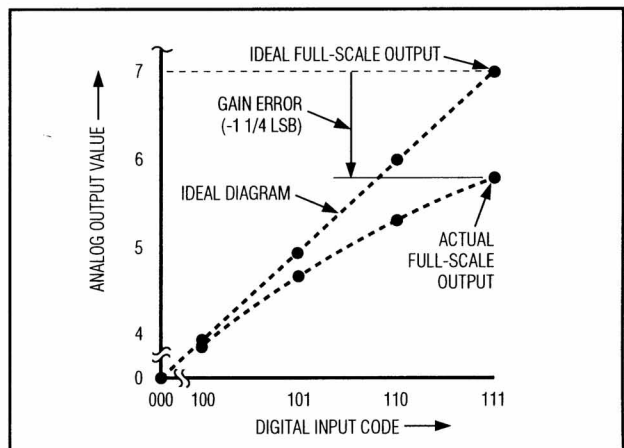

Figure 5d. Gain Error

FIGURE 6: Differential to Single-Ended Conversion Using a Low-Distortion Amplifier

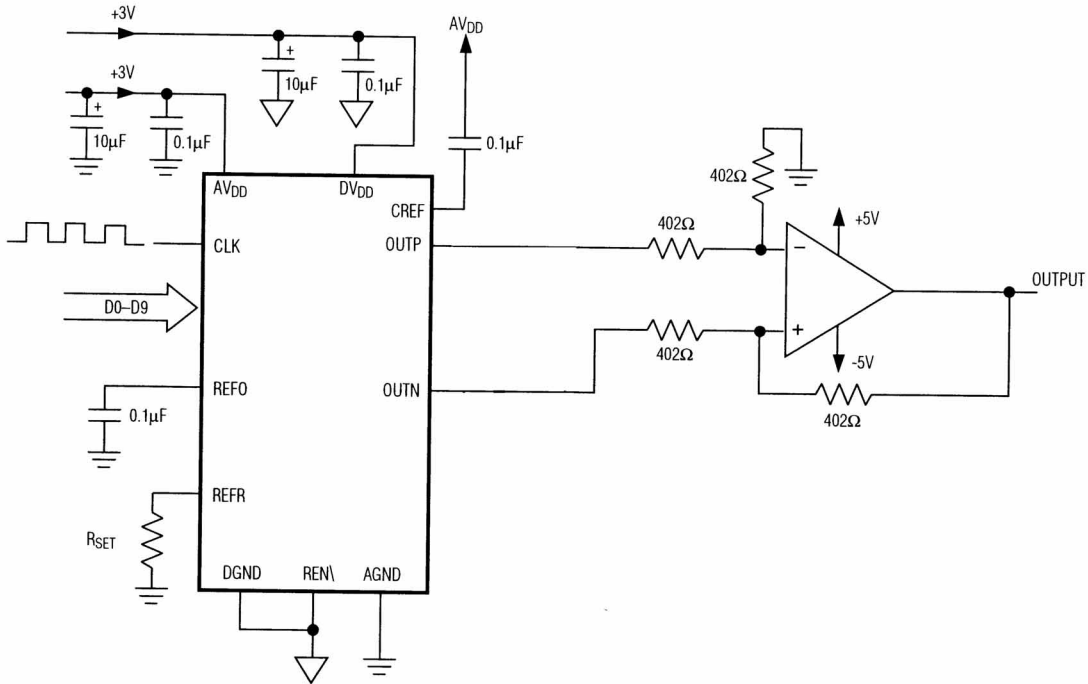
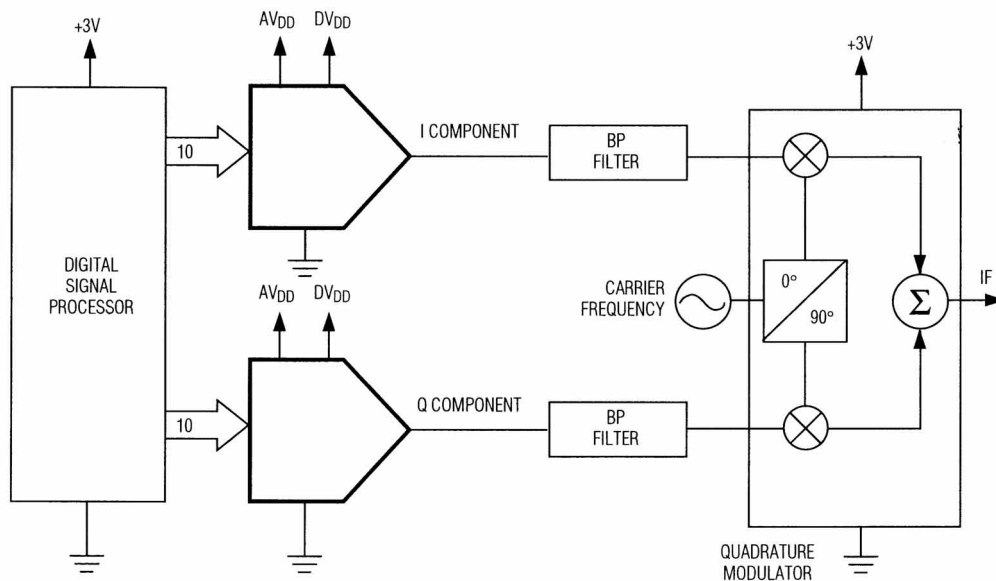

FIGURE 7: Using the AS5181 for I/Q Signal Reconstruction



Grounding and Power-Supply Decoupling

Grounding and power-supply decoupling strongly influence the AS5181's performance. Unwanted digital crosstalk may couple through the input, reference, power-supply, and ground connections, which may affect dynamic specifications like SNR or SFDR. In addition, electromagnetic interference (EMI) can either couple into or be generated by the AS5181. Therefore, grounding and power-supply decoupling guidelines for high-speed, high-frequency applications should be closely followed.

First, a multilayer PC board with separate ground and power-supply planes is recommended. High-speed signals should be run on controlled impedance lines directly above the ground plane. Since the AS5181 has separate analog and digital ground buses (AGND and DGND, respectively), the PC board should also have separate analog and digital ground sections with only one point connecting the two. Digital signals should

run above the digital ground plane, and analog signals should run above the analog ground plane.

The device has two power-supply inputs: analog V_{DD} (AV_{DD}) and digital V_{DD} (DV_{DD}). Each AV_{DD} input should be decoupled with parallel $10\mu F$ and $0.1\mu F$ ceramic-chip capacitors. These capacitors should be as close to the pin as possible, and their opposite ends should be as close as possible to the ground plane. The DV_{DD} pins should also have separate $10\mu F$ and $0.1\mu F$ capacitors adjacent to their respective pins. Try to minimize analog load capacitance for proper operation. For best performance, bypass with low-ESR $0.1\mu F$ capacitors to AV_{DD} .

The power-supply voltages should also be decoupled with large tantalum or electrolytic capacitors at the point they enter the PC board. Ferrite beads with additional decoupling capacitors forming a pi network can also improve performance.

FIGURES 8A and 8B

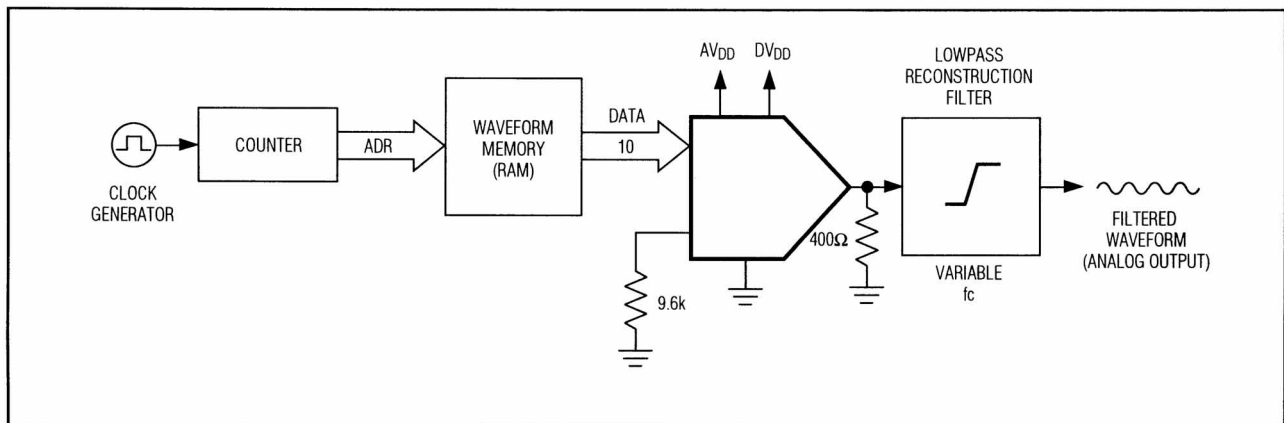

Figure 8a. Traditional Arbitrary Waveform Generation

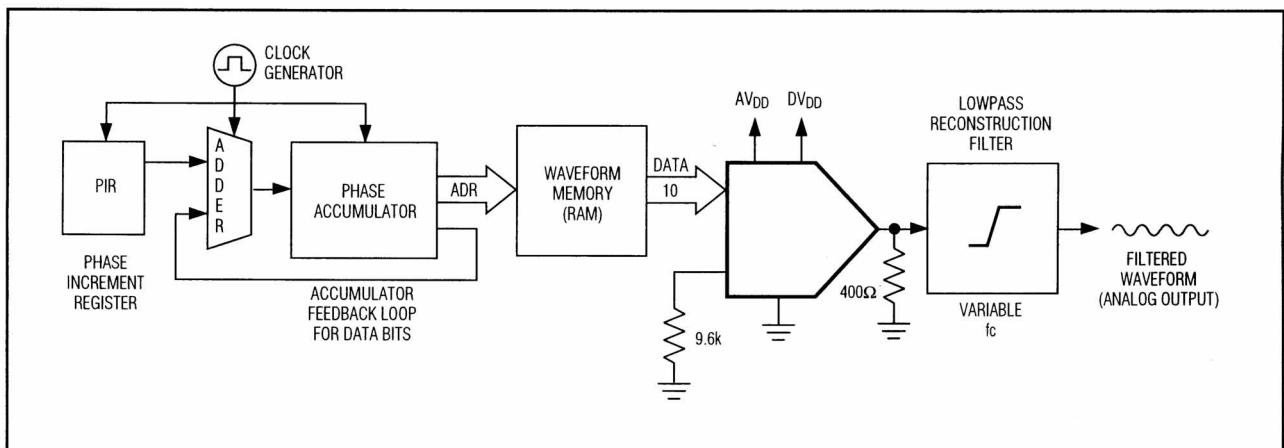
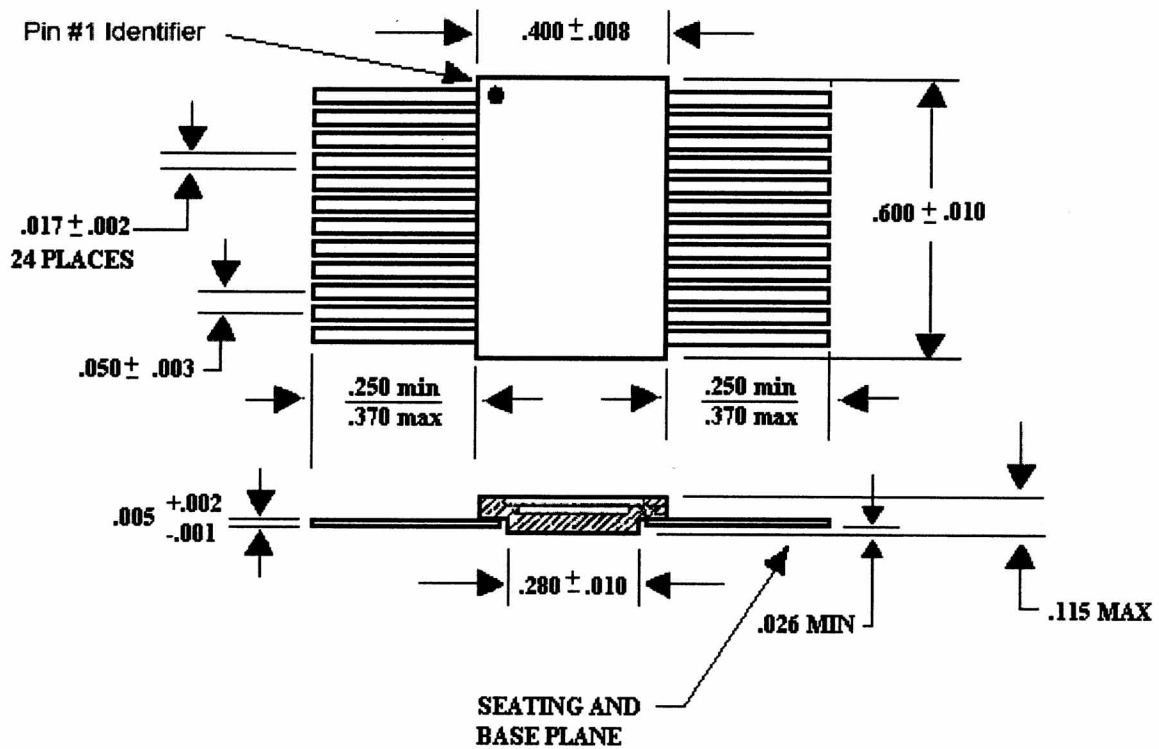

Figure 8b. Direct Digital Synthesis AWG

MECHANICAL DEFINITIONS*

24-Pin Flat Pack
(Package Designator F)



*All measurements are in inches.

ORDERING INFORMATION

EXAMPLE: AS5181F-MIL

Device Number	Package Type	Operating Temp.
AS5181	F	-*
AS5181	F	-*
AS5181	F	-*

*AVAILABLE PROCESSES

XT = Extended Temperature Range	-55°C to +125°C
IT = Industrial Temperature Range	-40°C to +85°C
MIL = Military Processing	-55°C to +125°C
SPACE = Space Processing	-55°C to +125°C