



U74AHC07

CMOS IC

NON-INVERT BUFFERS WITH OPEN-DRAIN OUTPUT

DESCRIPTION

The **U74AHC07** is a device with six independent non-inverting buffers and the output of the buffer is an open drain. Each buffer provides the Function $Y=A$.

FEATURES

- * Operate From 2V to 5.5V
- * High Noise Immunity
- * Low Power Dissipation
- * Balanced Propagation Delays
- * Output Capability Standard (Open Drain)

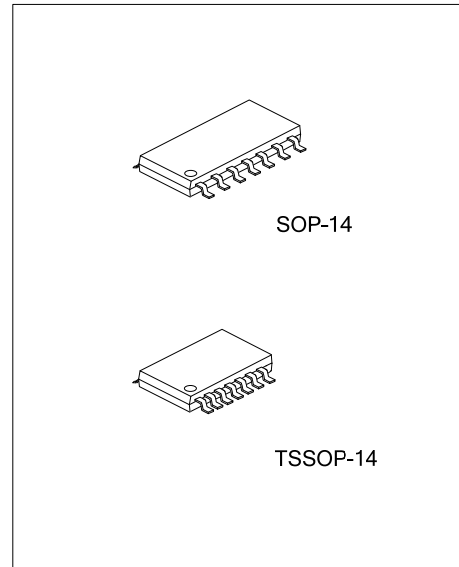

ORDERING INFORMATION

Ordering Number		Package	Packing
Lead Free	Halogen Free		
U74AHC07L-S14-T	U74AHC07G-S14-T	SOP-14	Tube
U74AHC07L-S14-R	U74AHC07G-S14-R	SOP-14	Tape Reel
U74AHC07L-P14-T	U74AHC07G-P14-T	TSSOP-14	Tube
U74AHC07L-P14-R	U74AHC07G-P14-R	TSSOP-14	Tape Reel

<p>U74AHC07L-S14-T</p> <p>(1)Packing Type (2)Package Type (3)Halogen Free</p>	<p>(1) T: Tube, R: Tape Reel (2) S14: SOP-14, P14: TSSOP-14 (3) L: Lead Free, G: Halogen Free</p>
---	---

■ PIN CONFIGURATION

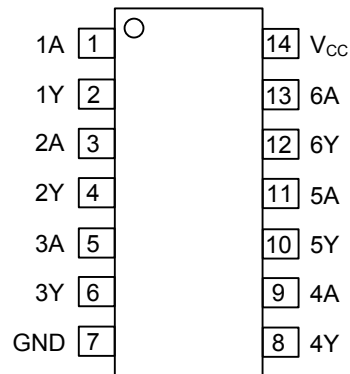

■ FUNCTION TABLE (Each Gate)

INPUT A	OUTPUT Y
H	Z
L	L

Note: H: High Voltage Level
 L: Low Voltage Level
 Z: High-Impedance OFF-State

■ LOGIC SYMBOL(each gate)

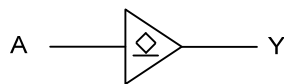

Logic Symbol

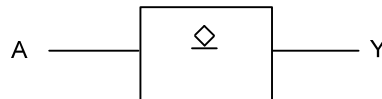

IEC Logic Symbol

■ ABSOLUTE MAXIMUM RATING (unless otherwise specified)

PARAMETER	SYMBOL	RATINGS	UNIT
Supply Voltage	V_{CC}	-0.5 ~ +7	V
Input Voltage	V_{IN}	-0.5 ~ +7	V
Output Voltage	V_{OUT}	Active Mode	-0.5 ~ $V_{CC} + 0.5$
		High-Impedance Mode	-0.5 ~ +7
V_{CC} or GND Current	I_{CC}	±75	mA
Output Sink Current ($V_{OUT} > -0.5V$)	I_{OUT}	±25	mA
Input Clamp Current ($V_{IN} < -0.5V$)	I_{IK}	-20	mA
Output Clamp Current ($V_{OUT} < -0.5V$)	I_{OK}	±20	mA
Operating Temperature	T_{OPR}	-40 ~ +85	°C
Storage Temperature	T_{STG}	-65 ~ + 150	°C

Note: 1. Absolute maximum ratings are those values beyond which the device could be permanently damaged.

Absolute maximum ratings are stress ratings only and functional device operation is not implied.

2. The input and output voltage ratings may be exceeded if the input and output current ratings are observed.

■ THERMAL DATA

PARAMETER	SYMBOL	RATINGS	UNIT
Junction to Ambient	SOP-14	76	°C/W
	TSSOP-14	113	°C/W

■ RECOMMENDED OPERATING CONDITIONS

PARAMETER	SYMBOL	CONDITIONS	MIN	TYP	MAX	UNIT
Supply Voltage	V_{CC}		2.0	5.0	5.5	V
Input Voltage	V_{IN}		0		5.5	V
Output Voltage	V_{OUT}	Active Mode	0		V_{CC}	V
		High-Impedance Mode	0		6.0	
High-Level Input Voltage	V_{IH}	$V_{CC} = 2.0V$	1.5			V
		$V_{CC} = 3.0V$	2.1			
		$V_{CC} = 5.5V$	3.85			
Low-Level Input Voltage	V_{IL}	$V_{CC} = 2.0V$			0.5	V
		$V_{CC} = 3.0V$			0.9	
		$V_{CC} = 5.5V$			1.65	
Input Transition Rise or Fall Rate	t_R / t_F	$V_{CC} = 3.3 \pm 0.3V$			100	ns/V
		$V_{CC} = 5.0 \pm 0.5V$			20	

■ STATIC CHARACTERISTICS (TA=25°C)

PARAMETER	SYMBOL	TEST CONDITIONS	MIN	TYP	MAX	UNIT
Low-Level Output Voltage	V_{OL}	$I_{OL} = 50\mu A$	$V_{CC} = 2.0V$		0.1	V
			$V_{CC} = 3.0V$		0.1	
		$I_{OL} = 4 mA$	$V_{CC} = 4.5V$		0.1	
			$V_{CC} = 3.0V$		0.36	
Input Leakage Current	$I_{I(LEAK)}$	$V_{IN} = 5.5V$ or GND, $V_{CC} = 0V$ to 5.5V			0.1	μA
3-State Output OFF-state Current	I_{OZ}	$V_{IN} = V_{IH}$ or V_{IL} , $V_{OUT} = V_{CC}$ or GND, $V_{CC} = 5.5V$			±0.25	μA
Quiescent Supply Current	I_Q	$V_{IN} = V_{CC}$ or GND, $I_{OUT} = 0$, $V_{CC} = 5.5V$			1	μA
Input Capacitance	C_{IN}			1.5	10	pF

■ SWITCHING CHARACTERISTICS (TA=25°C)

PARAMETER	SYMBOL	TEST CONDITIONS	MIN	TYP	MAX	UNIT	
Propagation Delay From Input(A) To Output(Y)	t_{PZL}	$V_{CC} = 3.3 \pm 0.3 V$	$C_L = 15 pF$		3.5	5.6	ns
			$C_L = 50 pF$		5.0	8.0	
	t_{PLZ}	$V_{CC} = 3.3 \pm 0.3 V$	$C_L = 15 pF$		5.8	7.9	
			$C_L = 50 pF$		8.3	11.5	
Propagation Delay From Input(A) To Output(Y)	t_{PZL}	$V_{CC} = 5 \pm 0.5 V$	$C_L = 15 pF$		2.5	3.9	ns
			$C_L = 50 pF$		3.6	5.5	
	t_{PLZ}	$V_{CC} = 5 \pm 0.5 V$	$C_L = 15 pF$		4.2	5.1	
			$C_L = 15 pF$				

		$C_L=50\text{ pF}$		6.0	7.5	
--	--	--------------------	--	-----	-----	--

■ TEST CIRCUIT AND WAVEFORMS

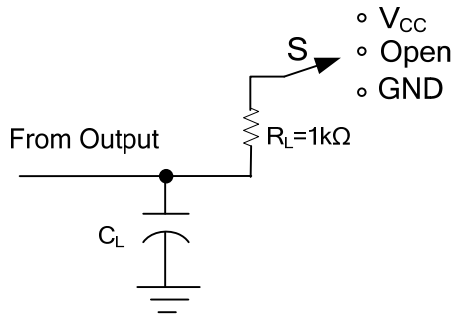

TEST	S
t_{PLH}/t_{PHL}	Open
t_{PHZ}/t_{PZH}	GND
t_{PLZ}/t_{PZL}	V_{CC}

Test circuit for measuring propagation delay

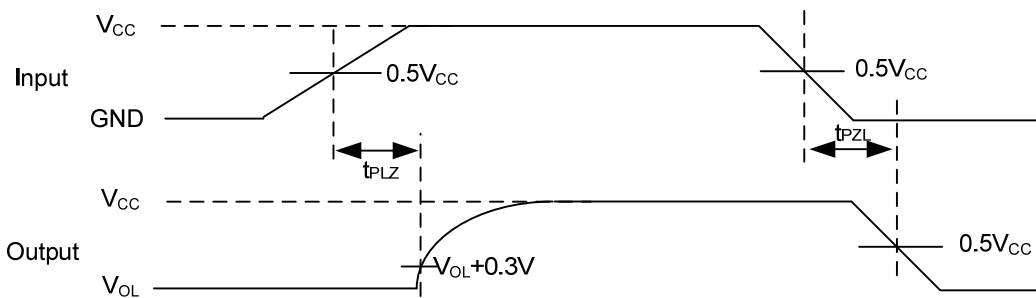

Waveforms showing the Input(A) to Output(Y) propagation delays.

Note: C_L includes probe and jig capacitance.

All input pulses are supplied by generators having the following characteristics: PRR $\leq 1\text{MHz}$, $Z_o = 50\Omega$, $t_r \leq 3\text{ns}$, $t_f \leq 3\text{ns}$.

UTC assumes no responsibility for equipment failures that result from using products at values that exceed, even momentarily, rated values (such as maximum ratings, operating condition ranges, or other parameters) listed in products specifications of any and all UTC products described or contained herein. UTC products are not designed for use in life support appliances, devices or systems where malfunction of these products can be reasonably expected to result in personal injury. Reproduction in whole or in part is prohibited without the prior written consent of the copyright owner. The information presented in this document does not form part of any quotation or contract, is believed to be accurate and reliable and may be changed without notice.