

PLEASE CHECK WWW.MOLEX.COM FOR LATEST PART INFORMATION

Part Number: [0190730172](#)
Status: **Active**
Description: Avikrimp™ Ring Tongue Terminal for 10 to 12 AWG Wire, Stud Size 10, Length 27.71mm (1.091"), Mylar Tape Carrier

Documents:

[Drawing \(PDF\)](#) [RoHS Certificate of Compliance \(PDF\)](#)

Agency Certification

CSA LR18689
 UL E32244

General

Product Family Ring and Spade Terminals
 Series [19073](#)
 Crimp Quality Equipment Yes
 Mil-Spec N/A
 Product Name Avikrimp™
 Type Ring

Physical

Barrel Type Closed
 Flammability 94V-0
 Insulation Nylon (PA)
 Material - Plating Mating Tin
 Packaging Type Adhesive Tape on Reel
 Stud Size 10 (M5)
 Wire Insulation Diameter 5.70mm (.225") max.
 Wire Size AWG 10, 12
 Wire Size mm² 0.40 - 0.60

Material Info

Old Part Number C-828-10T

Reference - Drawing Numbers

Sales Drawing SD-19073-007



EU RoHS

ELV and RoHS Compliant
REACH SVHC
 Not Reviewed
Halogen-Free Status
Not Reviewed

China RoHS



Need more information on product environmental compliance?

Email productcompliance@molex.com
 For a multiple part number RoHS Certificate of Compliance, [click here](#)

Please visit the [Contact Us](#) section for any non-product compliance questions.

Search Parts in this Series

[19073Series](#)

Application Tooling | [FAQ](#)

Tooling specifications and manuals are found by selecting the products below. Crimp Height Specifications are then contained in the Application Tooling Specification document.

Global

Description	Product #
Crimp Dies for MTA-100 Tape Applicator used in 3BF Press, MTA-105 Tape Applicator used in TM-2000™ Press, and ATP-301 Air Crimping Press for Mylar Tape Mounted Terminals	0192880179
Mini-Mac™ Applicator	0638851500

This document was generated on 05/24/2010

PLEASE CHECK WWW.MOLEX.COM FOR LATEST PART INFORMATION

MATERIAL NUMBER	ENG. NO.	MATERIAL NUMBER TAPE MOUNTED	ENG. NO.	STUD SIZE	"S" ±.005	"W" MAX	"C" MIN	"L" MAX
190730145	C-801-12	190730146	C-801-12T	12	.515 (13.08)	.760 (19.30)	.611 (15.52)	1.580 (40.13)
190730148	C-801-14	-----	-----	14	.265 (6.73)			
190730150	C-801-38	-----	-----	38	.390 (9.91)			
190730152	C-801-56	-----	-----	56	.328 (8.33)			
190730154	C-801-76	-----	-----	76	.453 (11.51)			
190730156	C-828-04	190730157	C-828-04T	04	.119 (3.02)	.385 (9.78)	.303 (7.70)	1.091 (27.71)
190730160	C-828-06	190730162	C-828-06T	06	.146 (3.71)			
190730165	C-828-08	190730167	C-828-08T	08	.173 (4.39)			
190730170	C-828-10	190730172	C-828-10T	10	.198 (5.03)			
190730175	C-828-14	-----	-----	14	.265 (6.73)			

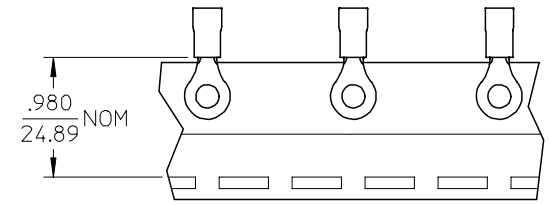
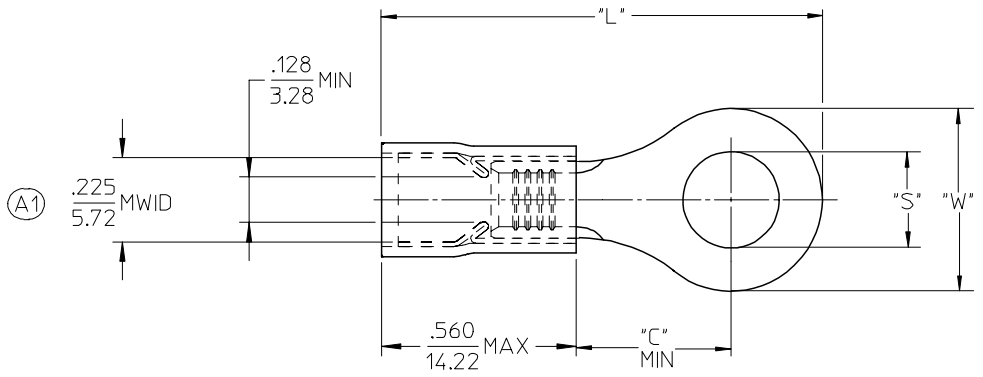

SALES DRAWING

- NOTES:
- MATERIAL: COPPER (.040/1.02) THICK. PLATING: ELECTROPLATE TIN
 - FERRULE: TIN PLATED BRASS
 - INSULATION: YELLOW NYLON
 - MWID=MAXIMUM WIRE INSULATION DIA.
 - ALL DIMENSIONS IN INCHES (MM).
 - WIRE SIZE: 12-10 AWG
4.0-6.0 MM²

EC NO: ETC2006-0152 DRWN: ASAYDEH 2005/12/12 CHKD: JLOMASTR 2005/12/13 APPR: RDEROSS 2005/12/14	QUALITY SYMBOLS	GENERAL TOLERANCES (UNLESS SPECIFIED)	SCALE 4:1	DESIGN UNITS INCH	THIRD ANGLE PROJECTION	REVISE ON CAD ONLY															
	DESCRIPTION ▼ - 0 ▽ - 0	<table border="1"> <thead> <tr> <th></th> <th>mm</th> <th>INCH</th> </tr> </thead> <tbody> <tr> <td>4 PLACES</td> <td>± ---</td> <td>± ---</td> </tr> <tr> <td>3 PLACES</td> <td>± ---</td> <td>± .005</td> </tr> <tr> <td>2 PLACES</td> <td>± 0.13</td> <td>± .01</td> </tr> <tr> <td>1 PLACE</td> <td>± 0.25</td> <td>± ---</td> </tr> </tbody> </table>		mm	INCH	4 PLACES	± ---	± ---	3 PLACES	± ---	± .005	2 PLACES	± 0.13	± .01	1 PLACE	± 0.25	± ---	DIMENSION STYLE IN/MM	TITLE	RING TONGUE TERMINAL AVIKRIMP, 800-SERIES 12-10 AWG	
			mm	INCH																	
		4 PLACES	± ---	± ---																	
3 PLACES	± ---	± .005																			
2 PLACES	± 0.13	± .01																			
1 PLACE	± 0.25	± ---																			
DRAFT WHERE APPLICABLE MUST REMAIN WITHIN DIMENSIONS	APPROVED BY RDEROSS DATE 03/12/15	CHECKED BY SBEITZEL DATE 03/12/15	MATERIAL NO. SEE CHART DOCUMENT NO. SD-19073-007	SHEET NO. 1 OF 1																	
REV A1	THIS DRAWING CONTAINS INFORMATION THAT IS PROPRIETARY TO MOLEX INCORPORATED AND SHOULD NOT BE USED WITHOUT WRITTEN PERMISSION					B															