

CRYSTAL CONTROLLED OSCILLATORS

14 PIN DIP 5.0V STRATUM 3 OCXO

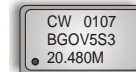
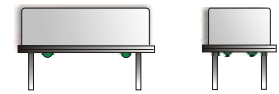

BGOV5S3

DESCRIPTION

The Connor-Winfield BGOV5S3 is a hermetically sealed 14 Pin DIP, 5.0V Oven Controlled Voltage Controlled Crystal Oscillator (OCVCXO) HCMOS output operating over the Industrial Temperature Range of -40 to 85°C. The BGOV5S3 is designed for a higher stability Stratum 3 application requiring low jitter and tight stability.

FEATURES

- 5.0V OPERATION
- LOW JITTER <3pS RMS
- FREQUENCY STABILITY ±0.25ppm
- TEMPERATURE RANGE: -40 to 85°C
- FREQUENCY TOLERANCE OF ±4.6ppm OVER TEN YEARS

ORDERING INFORMATION

BGOV5S3 - 20.480MHZ

OCXO
SERIES

CENTER
FREQUENCY

ABSOLUTE MAXIMUM RATINGS

TABLE 1.0

PARAMETER	UNITS	MINIMUM	NOMINAL	MAXIMUM	UNITS	NOTE
Storage Temperature		-55	-	100	°C	
Supply Voltage	(Vcc)	-0.5	-	7.0	Vdc	
Control Voltage	(Vc)	-0.5	-	7.0	Vdc	

OPERATING SPECIFICATIONS

TABLE 2.0

PARAMETER		MINIMUM	NOMINAL	MAXIMUM	UNITS	NOTE
Center Frequency	(Fo)	1.544	-	20.48	MHz	
Frequency Calibration (Vc = 2.18V)		-1.5	-	1.5	ppm	1, 4
Frequency vs. change in Temperature		-0.25	-	0.25	ppm	2
Frequency vs. change in Supply Voltage		-0.05	-	0.05	ppm	3
Aging (Lifetime)		-2.5	-	2.5	ppm	
Aging (1 st Year)		-1.5	-	1.5	ppm	
Total Frequency Tolerance		-4.6	-	4.6	ppm	5
Operating Temperature Range		-40	-	85	°C	
Supply Voltage	(Vcc)	4.75	5.00	5.25	Vdc	
Supply Current	(Icc)	-	-	350	mA	
Phase Jitter (BW = 12KHz to 20MHz)		-	-	1	pS RMS	
Phase Jitter (BW = 10Hz to 20MHz)		-	-	3	pS RMS	
Period Jitter		-	-	3	pS RMS	
Allan Variance (1 second)		-	5.00E-10	-		
SSB Phase Noise at 10Hz offset		-	-90	-	dBc/Hz	
SSB Phase Noise at 10KHz offset		-	-130	-	dBc/Hz	
Start Up Time: Oscillator		-	-	10	mS	
Warm Up Time		-	-	5	Minutes	6
TDEV @ 1.0 Sec.		-	-	1	nS	
TDEV @ 4.0 Sec.		-	-	2	nS	

INPUT CHARACTERISTICS

TABLE 3.0

PARAMETER		MINIMUM	NOMINAL	MAXIMUM	UNITS	NOTE
Control Voltage Range	(Vc)	0.5	2.18	4.1	Vdc	
Frequency at Vc=0.5 Vdc		-30	-	-18	ppm	7
Frequency at Vc=4.1 Vdc		18	-	30	ppm	7
Slope of Frequency Adjust		10	-	-	ppm/V	
Input Impedance		100k	-	-	Ohm	

HCMOS OUTPUT CHARACTERISTICS

TABLE 4.0

PARAMETER		MINIMUM	NOMINAL	MAXIMUM	UNITS	NOTE
LOAD		-	-	15	pf	
Voltage (High)	(Voh)	4.5	-	-	Vdc	
(Low)	(Vol)	-	-	0.4	Vdc	
Current (High)	(Ioh)	-4	-	-	mA	
(Low)	(loh)	-	-	4	mA	
Duty Cycle at 50% of Vcc		45	50	55	%	
Rise / Fall Time 10% to 90%		-	-	6	nS	

PACKAGE CHARACTERISTICS

TABLE 5.0

Package	14 pin DIP, hermetically sealed, grounded case, welded package
---------	--

Notes:

- 1) Initial calibration @ 25°C, Vc = 2.18V.
- 2) Frequency stability referenced to 25°C.
- 3) Frequency stability per 5% change in supply voltage.
- 4) At the time of shipment after 48 hours of operation.
- 5) Inclusive of calibration with Vc = 2.18V, operating temperature range, supply voltage change, load change, shock and vibration, 10 years aging.
- 6) Measured @ 25°C, within 5 minutes, the unit will be within +/-0.1ppm of its reference frequency, measured after 30 minutes of continuous operation at a stable 25°C
- 7) Referenced to Fo @ 25°C, Positive Transfer Characteristic.

Specifications subject to change without notice.

CRYSTAL CONTROLLED OSCILLATORS

ENVIRONMENTAL CHARACTERISTICS

Temperature Cycle: Per MIL-STD-883, Method 1010, Condition B. -55°C to 125°C, 20 cycles, 10 minute dwell, 1 minute transition.

Gross Leak Test: Per MIL-STD-202, Method 112, Condition D. No bubbles in flourinert (FC-43) at 125°C ±5°C for 20 seconds.

SOLDERING

Pin Solderability: Per MIL-STD-883, Method 200. 8 hour steam age prior to 254°C ±5°C Solder pot dip, 95% Coverage.

Resistance to Solder Heat: Per MIL-STD-202, Method 210, Condition C. Wave: Topside board-mount product, 260°C ±5°C for 20 Seconds.

MECHANICAL CHARACTERISTICS

Vibration: Per MIL-STD-202, Method 204, Condition A. 10G's peak, 10Hz to 500Hz, 15 minute cycles 12 times each perpendicular axis.

Shock: Per MIL-STD-202, Method 213, Condition D. 500G's, 1ms, half sine, 3 shocks per direction.

Moisture Resistance: Per MIL-STD-202, Method 106. 95% RH @ 65°C, 10 cycles 10°C to 65°C.

PACKAGE OUTLINE

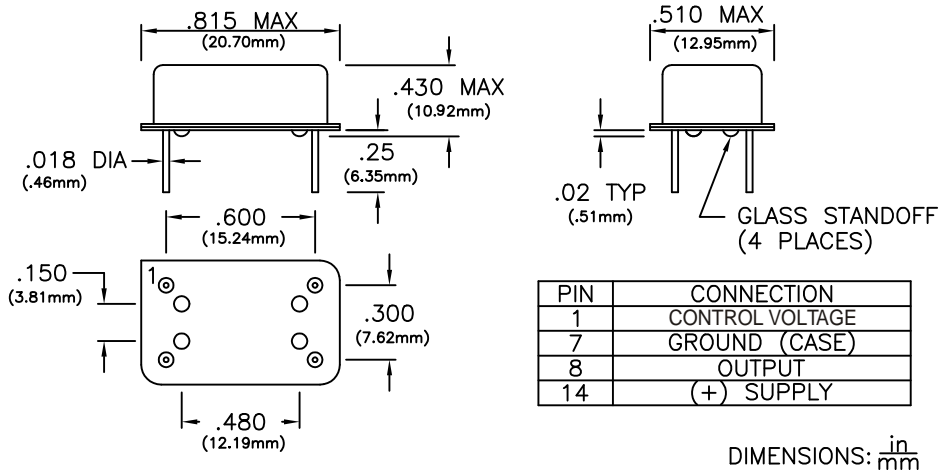

TEST DIAGRAM

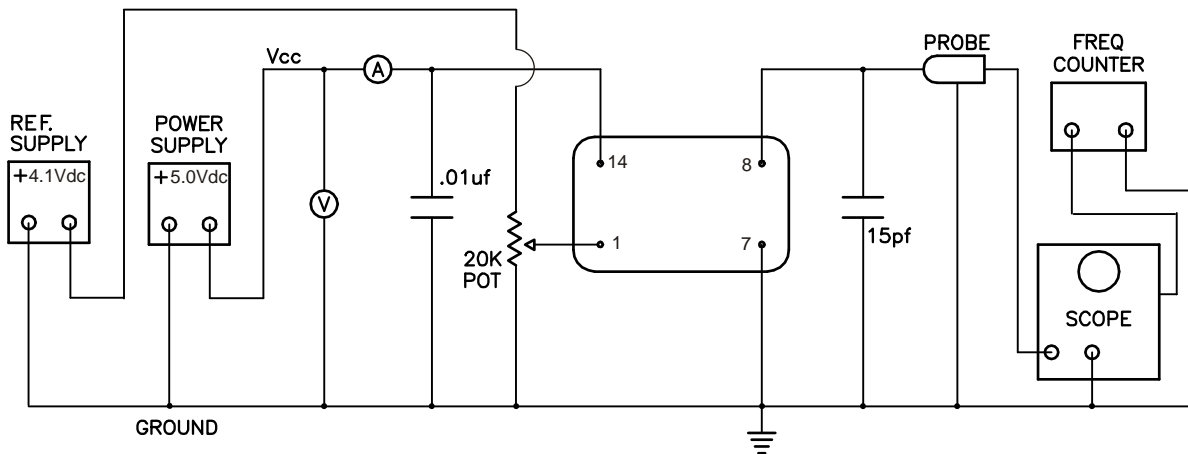

Specifications subject to change without notice.