

# Rectangular Multi-connector

## Series *KDM*

No. of Connecting Tubes: 10, 20

**Multi-connector is effective in saving labor for separate transportation of the panel and the machine, and for exchanging units due to failure.**

### Substantial reduction in mounting space

In comparison with a model requiring many union joints for panels and partitions, this model needs only a small space.

### One-touch connection/dis-connection of connector

Multiple pipes can be connected/disconnected in one-touch operation without connection error. Thus man-hours for connection/dis-connection are cut down substantially.

### One-touch tube connection

One-touch fittings substantially cuts down man-hours for piping.

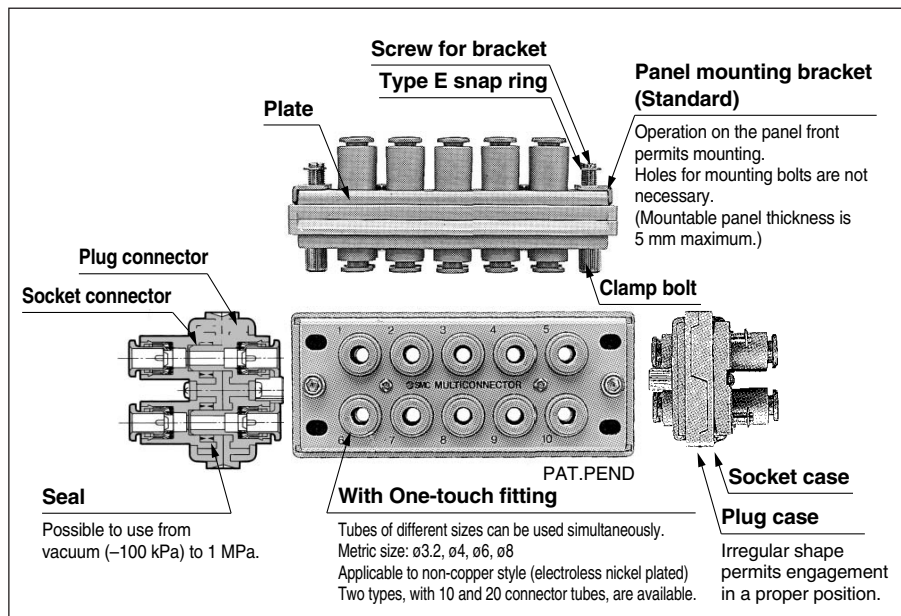
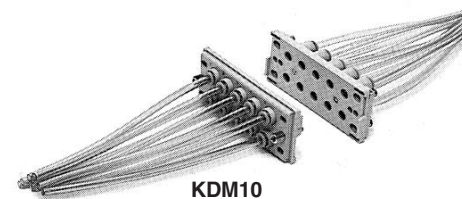
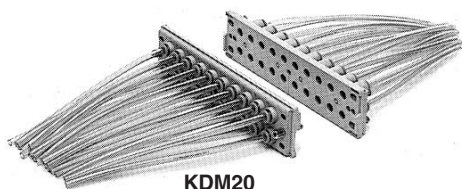

### Model

No. of connecting tubes	Tubing O.D.	Model	Weight	Color of release button
10	$\phi 3.2$	<b>KDM10-23</b>	300 g	Blue
	$\phi 4$	<b>KDM10-04</b>		
	$\phi 6$	<b>KDM10-06</b>		
	$\phi 8$	<b>KDM10-08</b>	520 g	
20	$\phi 3.2$	<b>KDM20-23</b>	520 g	
	$\phi 4$	<b>KDM20-04</b>		
	$\phi 6$	<b>KDM20-06</b>	950 g	
	$\phi 8$	<b>KDM20-08</b>		

### Applicable Tubing

Tubing material	Nylon, Soft nylon, Polyurethane
Tubing O.D.	$\phi 3.2$ , $\phi 4$ , $\phi 6$ , $\phi 8$

### Specifications

Fluid	Air
Maximum operating pressure	1.0 MPa
Operating vacuum pressure	-100 kPa
Proof pressure	1.5 MPa
Ambient and fluid temperature	-5 to 60°C (No freezing)

### ⚠ Caution

Be sure to read before handling. Refer to pages 15-18-3 to 15-18-4 for Safety instructions and Common Precautions on the products mentioned in this catalog, and refer to pages 15-1-10 to 15-1-11 for Precautions on every series.

## Principal Parts Material

Plug case, Socket case		POM
Plate, Bracket		SPCC plated
Plug connector, Socket connector	Body	PBT, C3604BD Electroless nickel plated (ø8)
	Chuck	Stainless steel 304
	Guide	Stainless steel 304, C3604BD Electroless nickel plated, POM (ø8)
	Collet, Release button	POM
	Seal	NBR
Clamp bolt, Screw for bracket, Cross-recessed head machine screw		SWRM, Nickel plated
Type E snap ring		Stainless steel 304

## Model

No. of connection tubes	Tubing O.D.	Model		Color of release button
		Plug	Socket	
10	ø3.2	<b>KDM10P-23</b>	<b>KDM10S-23</b>	Blue
	ø4	<b>KDM10P-04</b>	<b>KDM10S-04</b>	
	ø6	<b>KDM10P-06</b>	<b>KDM10S-06</b>	
	ø8	<b>KDM10P-08</b>	<b>KDM10S-08</b>	
20	ø3.2	<b>KDM20P-23</b>	<b>KDM20S-23</b>	
	ø4	<b>KDM20P-04</b>	<b>KDM20S-04</b>	
	ø6	<b>KDM20P-06</b>	<b>KDM20S-06</b>	
	ø8	<b>KDM20P-08</b>	<b>KDM20S-08</b>	

## Mixed Sizes of Plug Connectors and Socket Connectors

The rectangular multi-connector permits connector exchange in any desired position, thus allowing use of different sizes of tubes.

## Model

Connector	Tubing O.D.	Model	Color of release button
Plug connector	ø3.2	<b>KDMP-23</b>	Blue
	ø4	<b>KDMP-04</b>	
	ø6	<b>KDMP-06</b>	
	ø8	<b>KDMP-08</b>	
Socket connector (with packing)	ø3.2	<b>KDMS-23</b>	
	ø4	<b>KDMS-04</b>	
	ø6	<b>KDMS-06</b>	
	ø8	<b>KDMS-08</b>	

1. Loosen the cross-recessed head machine screw by using a Phillips screwdriver to remove the plate from the case.

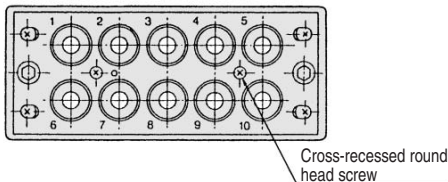

2. After exchanging connectors in desired places, fix the plate to the case by using a Phillips screwdriver.

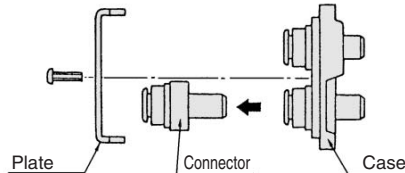

## How to Use

### ⚠ Caution

#### Separation

Loosen the clamp bolt to separate the plug side from the socket side.

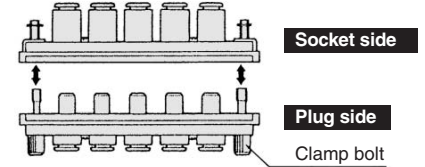

#### Connection

Put together the irregular faces for engagement and connect the plug case to the socket. After tightening the clamp bolt by hand, tighten it further with allen wrench (nominal width across flats: 4).

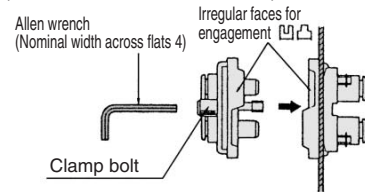

#### Panel mounting

1. Loosen (4) screws for bracket on the socket side using a Phillips screwdriver (JIS nominal No. 2) until the bracket touches the stop ring.

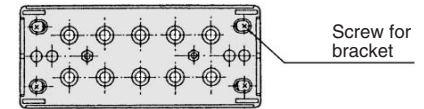

2. Shift the panel mounting bracket to the inside (Move the screw for bracket in the longitudinal direction of the slot) and put the connector in the panel mounting hole. (Panel-mounting hole: See Dimensions.)

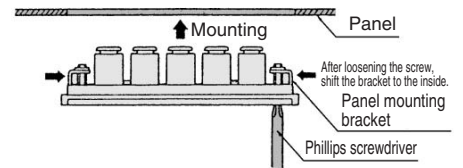

3. After shifting the bolt for bracket to the outside, tighten the bolt by a Phillips screwdriver to fix the socket case.

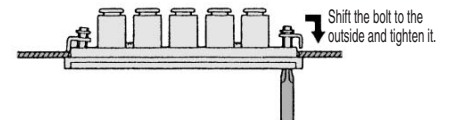

4. Loosen the screw for bracket until the bracket touches the stop ring and shift the bracket to the inside to remove the connector from the panel.

# Series KDM

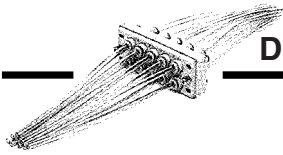

## Dimensions

### KDM10

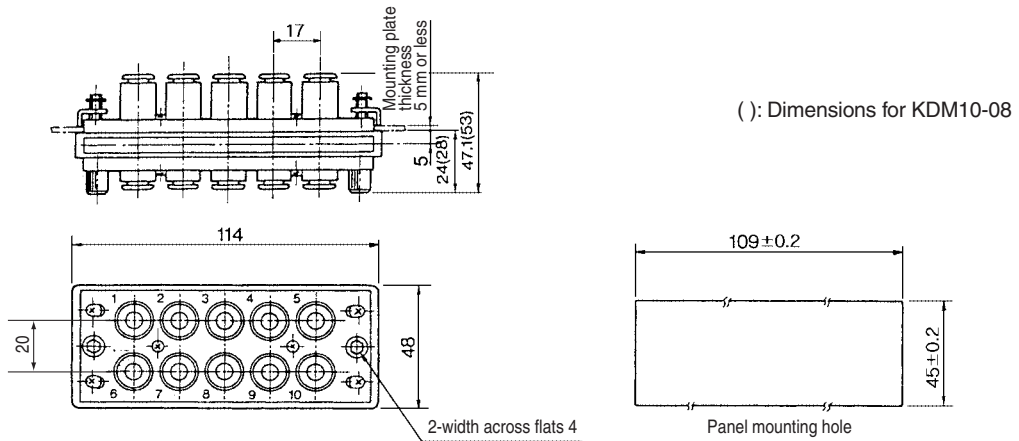

### KDM20

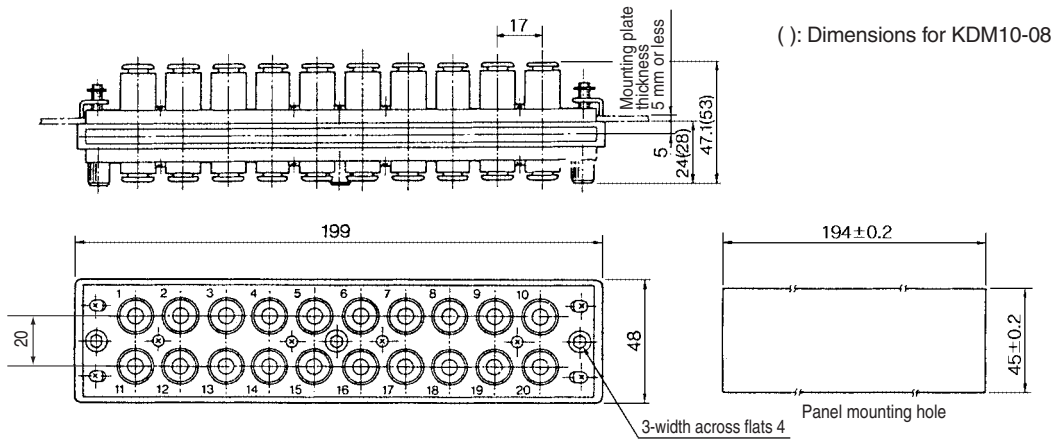

### Made to Order, Specifications

Please contact SMC for specifications in detail, dimensions and delivery.

#### ■ Mixed tubing size

Mixed tube size manifolds are available to meet your individual requirements. Please consult with your SMC sales representative for availability.

#### ■ Other tubing size

Tubing size (O.D.)	Number of tubes	Part no.
ø10	6	IN-254-52
ø12	6	IN-254-53