

Datasheet

# FS8853

300 mA LDO Linear Regulator

FORTUNE,  
Properties  
For Reference Only

**Fortune Semiconductor Corporation**

富晶電子股份有限公司

23F., No.29-5, Sec. 2, Zhongzheng E. Rd.,  
Danshui Town, Taipei County 251, Taiwan

Tel. : 886-2-28094742

Fax : 886-2-28094874

[www.ic-fortune.com](http://www.ic-fortune.com)

This manual contains new product information. **Fortune Semiconductor Corporation** reserves the rights to modify the product specification without further notice. No liability is assumed by **Fortune Semiconductor Corporation** as a result of the use of this product. No rights under any patent accompany the sale of the product.

### 1. General Description

The FS8853 is a low-dropout linear regulator that operations in the input voltage range from +2.5V to +9.0V and delivers 300mA output current.

The high-accuracy output voltage is preset at an internally trimmed voltage 1.8V to 3.3V. Other output voltages can be mask-optioned from 1.5V to 5.0V with 100mV increment.

The FS8853 consists of a 1.25V bandgap reference an error amplifier, and a P-channel pass transistor. Other features include short-circuit protection and thermal shutdown protection. The FS8853 devices are available in SOT-89 and SOT-23 packages.

### 2. Features

- Low dropout voltage 400mV at 300mA (Typ.)
- Up to  $\pm 35\text{mV}$  output voltage accuracy ( $V_{IN} \leq 7\text{V}$ )
- Preset at 1.8V, 3.3V
- Mask options from 1.5V to 5.0V
- Quiescent current 30 $\mu\text{A}$  at 5V input (Typ.)
- Small output capacitor
- Output current limit
- Thermal overload shutdown protection
- SOT-89 and SOT-23 Package

### 3. Applications

- Battery Powered Equipment
- Palmtops
- Portable Cameras and Video Recorders
- Reference Voltage Sources
- Post Regulator for Switching Power

### 4. Ordering Information

FS8853-xx x x

Package	Pin Out		
C : SOT-23	1.GND	2.OUT	3.IN
L : SOT-89	1.GND	2.IN	3.OUT
I : SOT-89	1.OUT	2.GND	3.IN

Package Type

G : G stands for Green-Package

Output Voltage

- 15 : 1.5V
- 18 : 1.8V
- 25 : 2.5V
- 28 : 2.8V
- 30 : 3.0V
- 33 : 3.3V
- 36 : 3.6V

Note: Mask option output types are available by order only

5. Pin Configurations

Part No.	Pin 1	Pin 2	Pin 3
FS8853 -xxGC	GND	OUT	IN

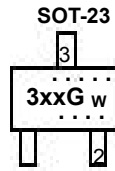

Part No.	Pin 1	Pin 2	Pin 3
FS8853 -xxGL	GND	IN	OUT
FS8853 -xxGI	OUT	GND	IN

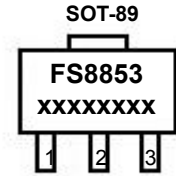

6. Package Marking Information

SOT-23	SOT-89
<p>EX : FS8853-33GC</p> <p>Top Point : Lot No. Bottom Point : Year w : week, A~Z &amp; A ~ Z</p>	<p>EX : FS8853-33GL</p> <p>xxxx : Date Code</p>

7. Pin Description

Part NO.	Symbol	Description
FS8853-xxGC FS8853-xxGL FS8853-xxGI	GND	Ground pin that provides the reference for all voltages.
	IN	Regulator input pin. Supply voltage can range from 2.5V to 9.0V. Bypass with a 1 $\mu$ F capacitor to GND.
	OUT	Regulator output pin. Sources up to 300mA. Bypass with a 3.3 $\mu$ F capacitor to GND.

8. Functional Block Diagram

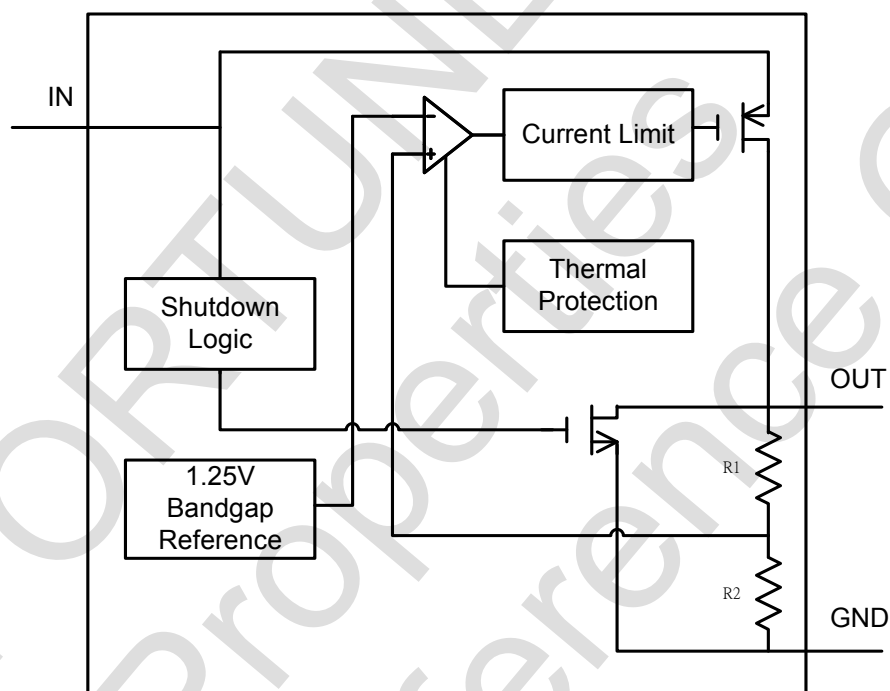

9. Typical Application Circuit

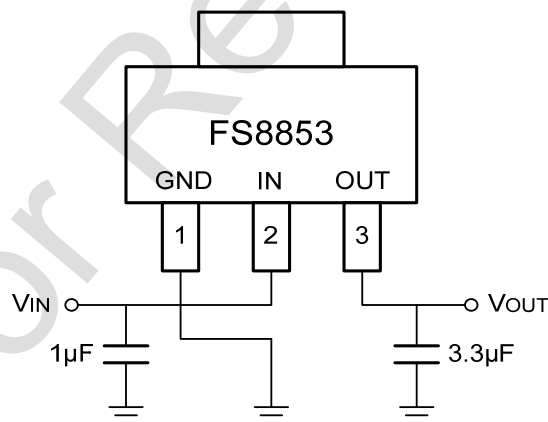

**10. Absolute Maximum Ratings**

Input voltage VIN to GND	-----9V
Output current limit, I(LIMIT)	-----0.6A
Continuous power dissipation, PD ( $\Delta T = T_J - T_A = 100^\circ\text{C}$ )	
SOT-23	-----0.30W
SOT-89	-----0.55W

\* The power dissipation values are based on the condition that junction temperature  $T_J$  and ambient temperature  $T_A$  difference is  $100^\circ\text{C}$ .

Junction Temperature, $T_J$	-----+155°C
Storage temperature range, TSTG	----- -55°C to +150°C
Operating junction temperature range	----- -40°C to +125°C
Lead temperature (soldering, 10sec)	----- 260°C

Stresses beyond those listed under “absolute maximum ratings” may cause permanent damage to the device. These are stress ratings only, and function operation of the device at these or any other conditions beyond those indicated under “recommended operating conditions” is not implied. Exposure to absolute-maximum-rated conditions for extended periods may affect device reliability.

**11. Electrical Characteristics**

(TA=25°C, unless otherwise noted.)

Symbol	Parameter	Test Conditions	Min	Typ	Max	Unit
VIN	Input Voltage		2.5		7.0	V
VOUT	Output Voltage	VIN=VOUT+0.48V, IOU=1mA, VIN ≤ 7V	VOUT-2.0%	VOUT	VOUT+2.0%	V
IMAX	Maximum Load Current		300			mA
ILIMIT	Current Limit				0.6	A
ISC	Short-Circuit Current	VOUT=0V, VIN=5.0V		300	350	mA
IQ	Ground Pin Current	IOU=0mA to 300mA, VIN=5.0V		30	50	µA
VDROP	Dropout Voltage	IOU=1mA		1.1	1.3	mV
		IOU=100mA		120	145	mV
		IOU=300mA		400	480	mV
ΔVLIN	Line Regulation	VOUT+0.48V<VIN<9V, IOU=1mA		0.2	0.3	%/V
ΔVLOAD	Load Regulation	IOU=0mA to 300mA		0.01	0.02	%/mA
eN	Output Noise	F=1Hz to 10KHz, COU=3.3µF, IOU=0mA		70		µVRMS
PSRR	Ripple Rejection	F=1KHz, COU=3.3µF		70		dB
TSD	Thermal Shutdown Temperature			155		°C
THYS	Thermal Shutdown Hysteresis			10		°C
θJA	Thermal Resistance	SOT-23			320	°C/W
		SOT-89			180	°C/W

## 12. Typical Operating Characteristics

(VIN=5.0V, CIN=1μF, COUT=3.3μF, TA=+25°C, FS8853-33PL tested, unless otherwise noted.)

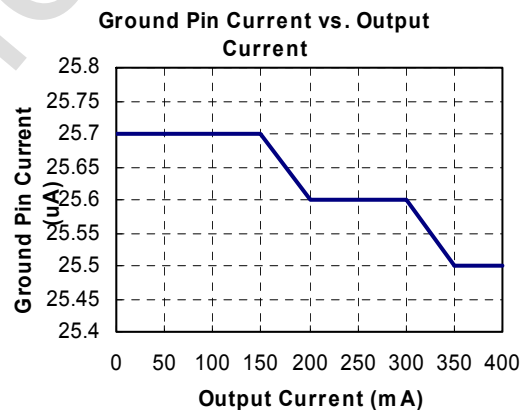
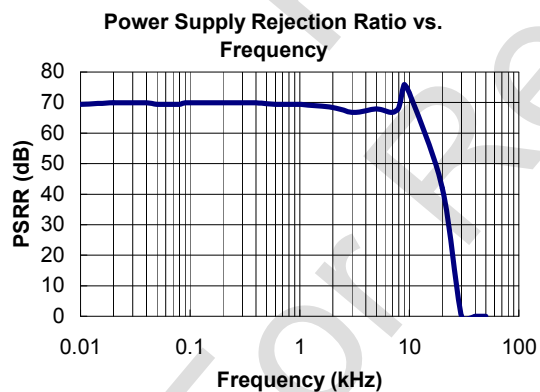
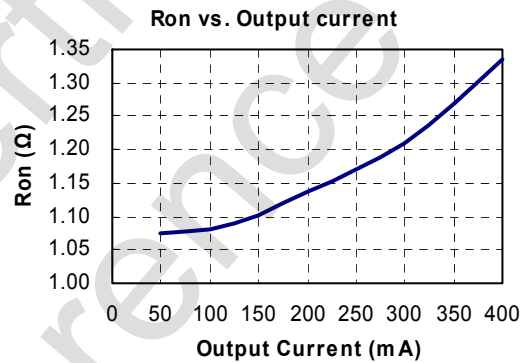
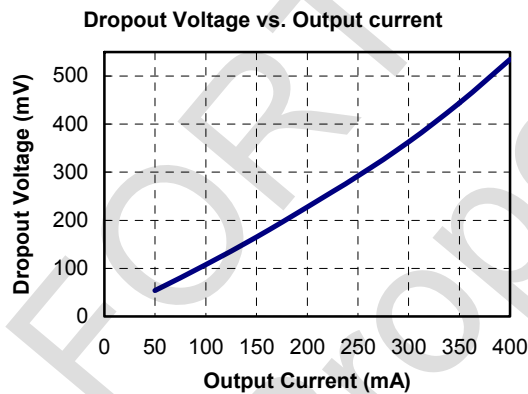
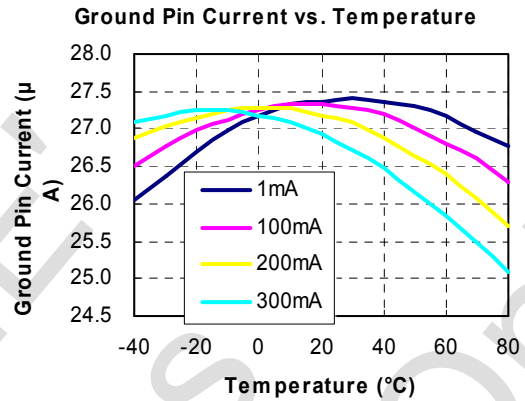
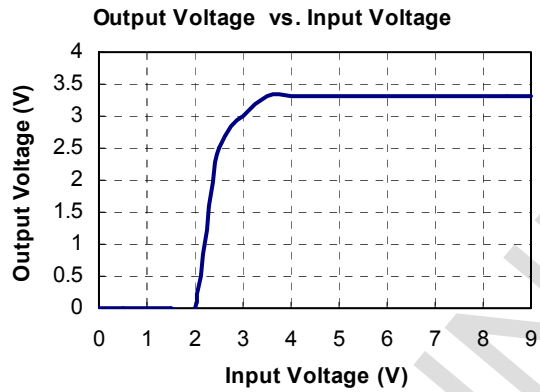



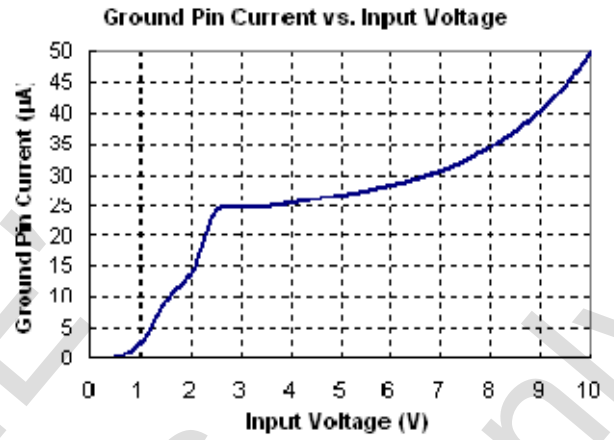
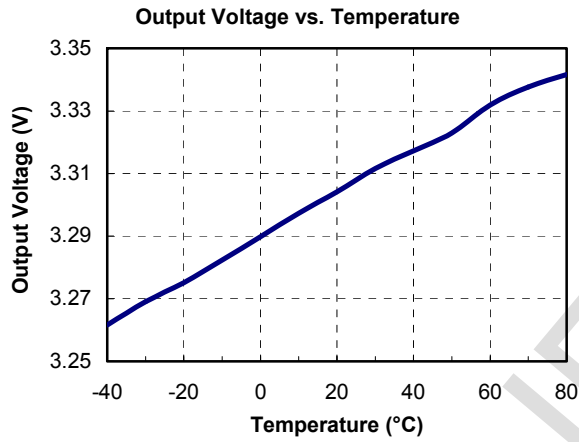

Output Noise DC to 1MHz (60.9µVRMS), IOUT=0mA

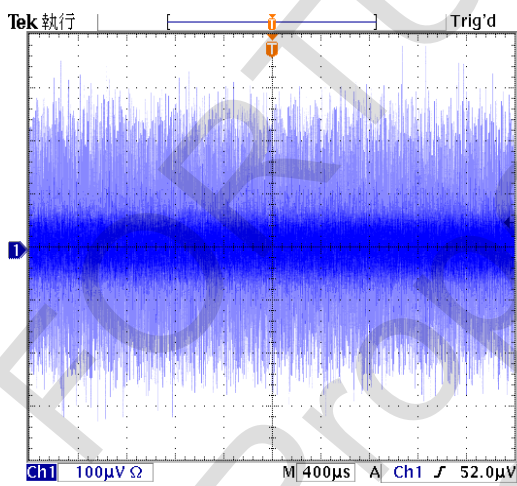

Output Noise DC to 1MHz (371µVRMS), IOUT=300mA

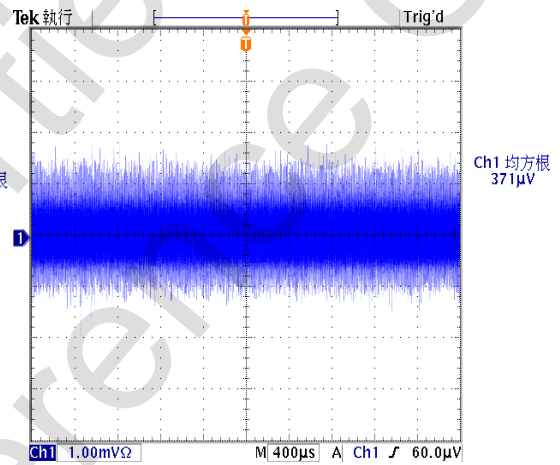

Line Transient (IOUT=1mA, VIN=4V-5V)

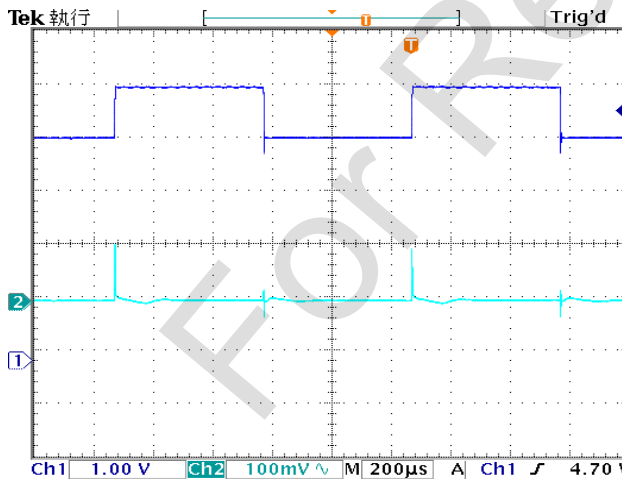

Line Transient (IOUT=10mA, VIN=4V-5V)

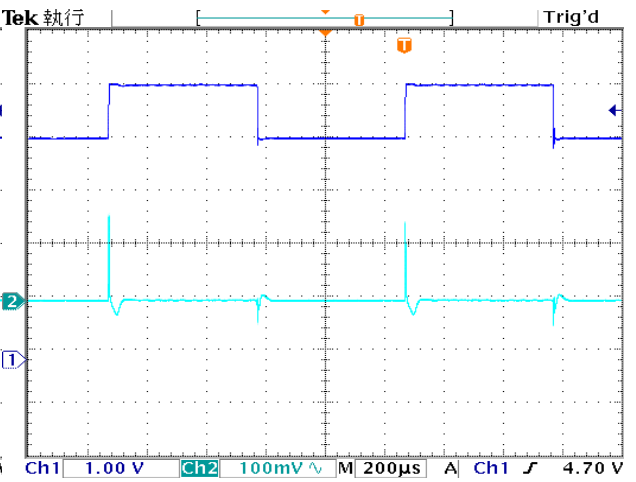

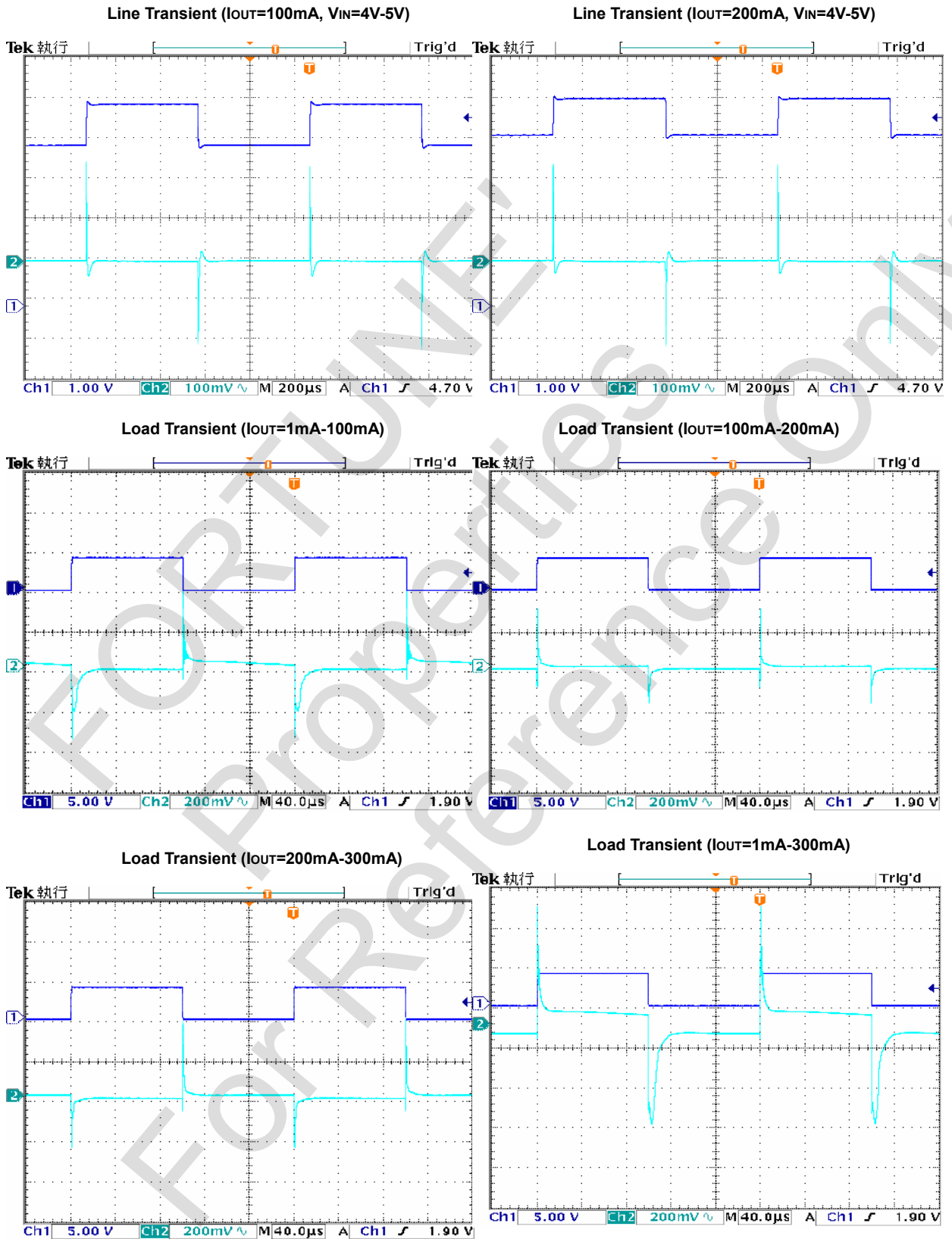

### 13. Detail Description

The FS8853 is a low-dropout linear regulator. The device provides preset 1.8V and 3.3V output voltages for output current up to 300mA. Other mask options for special output voltages from 1.5V to 5.0V with 100mV increment are also available. As illustrated in function block diagram, it consists of a 1.25V reference, error amplifier, P-channel pass transistor and an internal feedback voltage divider.

The 1.25V bandgap reference is connected to the error amplifier, which compares this reference with the feedback voltage and amplifies the voltage difference. If the feedback voltage is lower than the reference voltage, the pass-transistor gate is pulled lower, which allows more current to pass to the output pin and increases the output voltage. If the feedback voltage is too high, the pass-transistor gate is pulled up to decrease the output voltage.

The output voltage is feedback through an internal resistive divider connected to OUT pin. Additional blocks include an output current limiter, thermal sensor, and shutdown logic.

#### Internal P-channel Pass Transistor

The FS8853 features a P-channel MOSFET pass transistor. Unlike similar designs using PNP pass transistors, P-channel MOSFETs require no base drive, which reduces ground pin current. PNP-based regulators also waste considerable current in dropout when the pass transistor saturates, and use high base-drive currents under large loads. The FS8853 does not suffer from these problems and consumes only 30µA (Typ.) of ground pin current under heavy loads as well as in dropout conditions.

#### Output Voltage Selection

The FS8853 output voltage is preset at an internally trimmed voltage 1.8V, 3.3V or can be mask-optioned from 1.5V to 5.0V with 100mV increment. The first two digits of part number suffix identify the output voltage (see Ordering Information). For example, the FS8853-33CL has a preset 3.3V output voltage.

#### Current Limit

The FS8853 also include a fold back current limiter. It monitors and controls the pass transistor's gate voltage, estimates the output current, and limits the output current within 0.6A.

#### Thermal Overload Protection

Thermal overload protection limits total power dissipation in the FS8853. When the junction temperature exceeds  $T_J = +155^{\circ}\text{C}$ , a thermal sensor turns off the pass transistor, allowing the IC to cool down. The thermal sensor turns the pass transistor on again after the junction temperature cools down by  $20^{\circ}\text{C}$ , resulting in a pulsed output during continuous thermal overload conditions.

Thermal overload protection is designed to protect the FS8853 in the event of fault conditions. For continuous operation, the maximum operating junction temperature rating of  $T_J = +125^{\circ}\text{C}$  should not be exceeded.

#### Operating Region and Power Dissipation

Maximum power dissipation of the FS8853 depends on the thermal resistance of the case and circuit board, the temperature difference between the die junction and ambient air, and the rate of airflow. The power dissipation across the devices is  $P = I_{OUT} \times (V_{IN} - V_{OUT})$ . The resulting maximum power dissipation is:

$$P_{MAX} = \frac{(T_J - T_A)}{\theta_{JC} + \theta_{CA}} = \frac{(T_J - T_A)}{\theta_{JA}}$$

Where  $(T_J - T_A)$  is the temperature difference between the FS8853 die junction and the surrounding air,  $\theta_{JC}$  is the thermal resistance of the package chosen, and  $\theta_{CA}$  is the thermal resistance through the printed circuit board, copper traces and other materials to the surrounding air. For better heat-sinking, the copper area should be equally shared between the IN, OUT, and GND pins.

If the FS8853 uses a SOT-89 package and this package is mounted on a double sided printed circuit board with two square inches of copper allocated for “heat spreading”, the resulting  $\theta_{JA}$  is 180 °C/W.

Based on a maximum operating junction temperature 125 °C with an ambient of 25°C, the maximum power dissipation will be:

$$P_{MAX} = \frac{(T_J - T_A)}{\theta_{JC} + \theta_{CA}} = \frac{(125 - 25)}{180} = 0.555W$$

Thermal characteristics were measured using a double sided board with 1” x 2” square inches of copper area connected to the GND pin for “heat spreading”.

### Input-Output Voltage

A regulator's minimum input-output voltage differential, or dropout voltage, determines the lowest usable supply voltage. In battery-powered systems, this will determine the useful end-of-life battery voltage. The FS8853 uses a P-channel MOSFET pass transistor, its dropout voltage is a function of drain-to-source on-resistance (RDS(ON)) multiplied by the load current.

$$VDROPOUT = V_{IN} - V_{OUT} = R_{DS(ON)} \times I_{OUT}$$

14. Package Outline

SOT-23

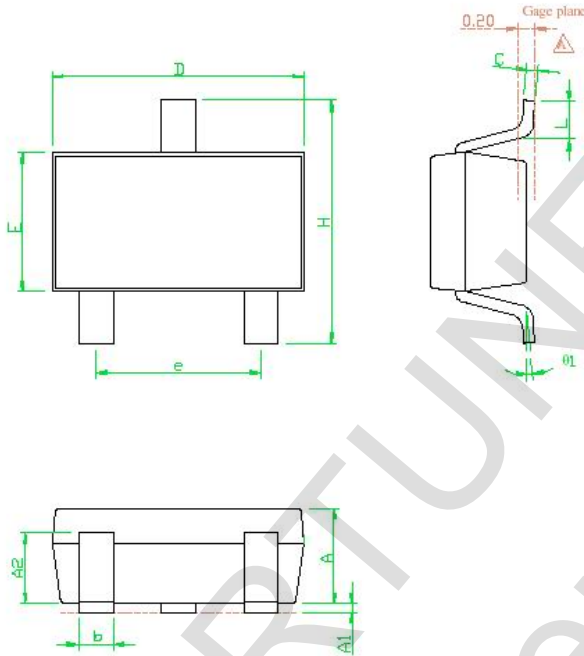

- NOTE
1. PACKAGE BODY SIZES EXCLUDE MOLD FLASH PROTRUSIONS OR GATE BURRS
  2. TOLERANCE  $\pm 0.1000$  mm (4 mil) UNLESS OTHERWISE SPECIFIED
  3. COPLANARITY : 0.1000 mm
  4. DIMENSION L IS MEASURED IN GAGE PLANE

SYMBOLS	DIMENSIONS IN MILLIMETERS		
	MIN	NOM	MAX
A	1.00	1.10	1.30
A1	0.00	---	0.10
A2	0.70	0.80	0.90
b	0.35	0.40	0.50
C	0.10	0.15	0.25
D	2.70	2.90	3.10
E	1.40	1.60	1.80
e	---	1.90(TYP)	---
H	2.60	2.80	3.00
L	0.37	---	---
$\theta 1$	1°	5°	9°

SOT-89

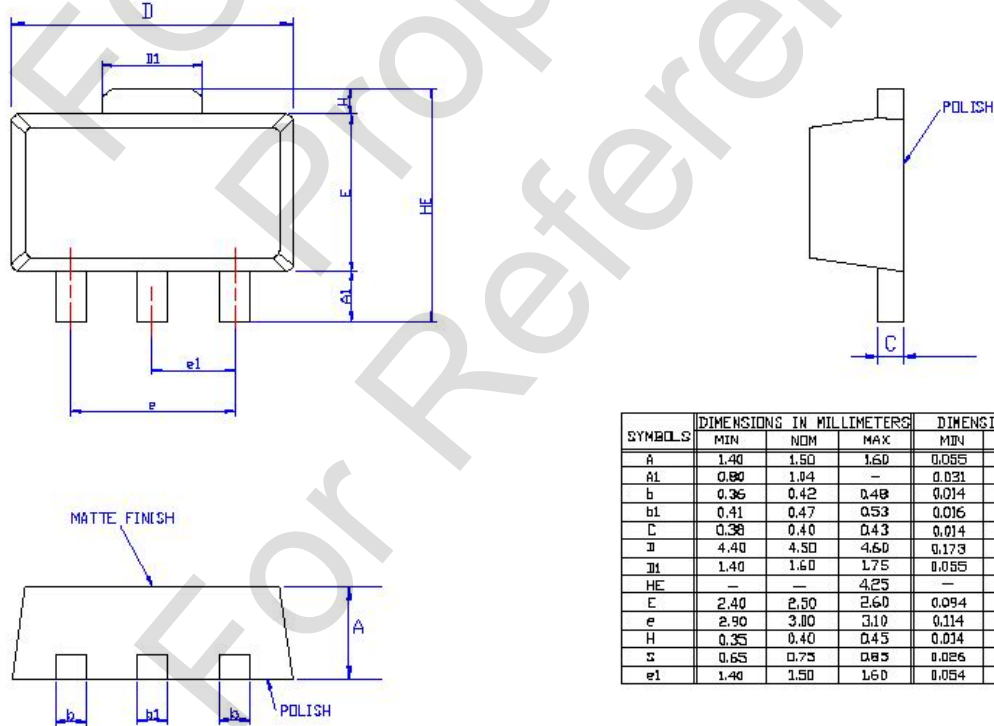

SYMBOLS	DIMENSIONS IN MILLIMETERS			DIMENSIONS IN INCHES		
	MIN	NOM	MAX	MIN	NOM	MAX
A	1.40	1.50	1.60	0.055	0.059	0.063
A1	0.80	1.04	---	0.031	0.041	---
b	0.35	0.42	0.48	0.014	0.016	0.018
b1	0.41	0.47	0.53	0.016	0.018	0.020
C	0.38	0.40	0.43	0.014	0.015	0.017
D	4.40	4.50	4.60	0.173	0.177	0.181
H	1.40	1.60	1.75	0.055	0.062	0.069
HE	---	---	4.25	---	---	0.167
E	2.40	2.50	2.60	0.094	0.098	0.102
e	2.90	3.00	3.10	0.114	0.118	0.122
H	0.35	0.40	0.45	0.014	0.016	0.018
L	0.65	0.75	0.85	0.026	0.030	0.034
e1	1.40	1.50	1.60	0.054	0.059	0.063

**15. Revision History**

Version	Date	Page	Description
1.1	2003/04/08	1	Features: The original statement of "Logic Control Shutdown Function" is a misdescription.
1.1	2003/04/08	1	Ordering Information: The meaning of "C" in Temperature Range is revised from "-40°C to +70°C" to "Commercial Standard".
1.1	2003/04/08	4	Absolute Maximum Ratings : Add Operating Junction Temperature Range -40°C to +125°C; Operating Ambient Temperature Range is revised from "-40°C to +80°C" to "-40°C to +85°C"
1.!	2003/04/08	5	Electrical Characteristics: Revise "Fixed Voltage Type $V_{IN} \geq V_{OUT} + 0.4V$ " to " $V_{IN} \geq V_{OUT} + 0.48V$ ". Divide "Output Voltage Accuracy" into two sections: When $V_{IN} \leq 7V$ , it is $\pm 35mV$ ; when $7V < V_{IN} \leq 9V$ , it is $\pm 42mV$ . For the MAX. value of Dropout Voltage, when $I_{OUT} = 1mA$ , 1.15mV is revised to 1.30mV; when $I_{OUT} = 100mA$ , 130mV is revised to 145mV; when $I_{OUT} = 300mA$ , 400mV is revised to 480mV.
1.2	2003/05/09	5	Electrical Characteristics : Cancel example $V_{OUT} = 3.3V$ , and show the whole range of $V_{OUT}$ (Fixed Voltage Type $V_{OUT} = 1.3V \sim 4.5V$ )
1.2	2003/05/09	6	Typical Operating Characteristics: Cancel example $V_{OUT} = 3.3V$ , and show the whole range of $V_{OUT}$ (Fixed Voltage Type $V_{OUT} = 1.3V \sim 4.5V$ )
1.3	2003/12/12	1	General Description: Change "But for FS8853-19Cx, the output is 1.85V. For FS8853-29Cx, the output is 2.85V." to "except FS8853-29Cx which has 2.85V output voltage."
1.3	2003/12/12	1	Features : Change "Low dropout voltage 120mV at 100mA" to "Low dropout voltage 400mV at 300mA"
1.3	2003/12/12	1	Ordering Information: Change 1.85V option to 1.9V.
1.3	2003/12/22	5	Electrical Characteristics: Change dropout voltage at $I_{OUT} = 300mA$ from 380mV to 400mV.
1.4	2004/03/16	1	General Description: Correct wording.
1.4	2004/03/16	3	Pin description: Correct wording.
1.4	2004/03/16	3	Change Function Block Diagrams to Functional Block Diagrams.
1.4	2004/03/16	4	Change Typical Application Schematic to Typical Application Circuit.
1.4	2004/03/16	4	Absolute Maximum Ratings: Remove Operating ambient temperature range.
1.4	2004/03/16	5	Electrical Characteristics: Add Symbol column.
1.4	2004/03/16	6	Typical Operating Characteristics: Change all labels "TEMPERATURE" to "AMBIENT TEMPERATURE". Current header "Ron vs. LOAD CURRENT"
1.4	2004/03/16	9/10	Detail Description: Correct wording.
1.4	2004/03/16	11	Change Package Information to Package Outline
1.4	2004/03/16	11/12 /13	Package Outline : Update SOT-23/SOT-89/TO-92 package diagrams.
1.4	2004/03/16	All	Update page header and footer to standard format. Update page layout and style to standard format.
1.5	2004/05/11	1	Ordering Information: Add Pb/P free package option
1.5	2004/05/11	2	Pin Configurations: Change SOT-23 marking
1.5	2004/05/11	2	Package Marking Information: Change SOT-23 marking information, Add Pb/P free package marking information
1.5	2004/05/11	4	Absolute Maximum Rating: Change continuous power dissipation values and add notes. Add maximum junction temperature +155°C.



Version	Date	Page	Description
1.5	2004/05/11	5	Electrical Characteristics: Change thermal shutdown temperature from 170°C to 155°C.
1.5	2004/05/11	5	Electrical Characteristics: Change thermal resistance of SOT-89 from 150 to 180. Change thermal resistance of TO-92 from 220 to 180.
1.5	2004/05/11	10	Operating Region and Power Dissipation: Change the result of power dissipation calculation example for SOT-89. The calculated value is based on new thermal resistance and recommended operating temperature range.
1.6	2004/10/12	2	Package Marking Information: Change SOT-23 marking information. Change Pb/P free package marking from "4 <sup>th</sup> digit with under line" to "a dot after marking".
2.0	2005/05/10	All	Update header/footer with new format.
2.0	2005/05/10	1	General Description: Update output voltages from "1.3V~4.5V" to "1.5V~5.0V".
2.0	2005/05/10	1	Features: Update output voltages from "1.3V~4.5V" to "1.5V~5.0V". Add "Quiescent current 30μA at 5V input."
2.0	2005/05/10	1	Ordering Information: Delete V,D,F,W,K,Y pin-out types. Update output voltages from "1.3V~4.5V" to "1.5V~5.0V".
2.0	2005/05/10	2	Pin Configurations: Delete V,D,F,W,K,Y pin-out types.
2.0	2005/05/10	3	Pin description: Delete V,D,F,W,K,Y pin-out types. Move pin descriptions into table.
2.0	2005/05/10	3	Typical Application Circuit: Update pin-out and connection diagram.
2.0	2005/05/10	5	Electrical Characteristics: Change the short-circuit current spec. from "Typ 140mA Max 160mA" to "Typ 300mA Max 350mA". Change the ground pin current spec. form "Typ 65μA Max 120μA" to "Typ 30uA Max 50μA". Change the test condition for previous two spec. to Vin=5.0V. Change PSRR spec. form "75dB @ 10KHz" to "70dB @ 1KHz" Change thermal shutdown hysteresis spec. from 20 to 10.
2.0	2005/05/20	6~8	Typical Operating Characteristics: Update all graphs.
2.0	2005/05/10	9	Detail Description: Update output voltages from "1.3V~4.5V" to "1.5V~5.0V". Update quiescent current form "65μA" to "30μA".
2.1	2006/09/27	All	Revise datasheet format
2.2	2009/08/05	3	Ordering Information: Update package C、L、I Update package type G stands for Green-Package Update Output Voltage 18 : 1.8V、29 : 2.9V、30 : 3.0V、33 : 3.3V
2.3	2009/12/09	7~8	Vin Absolute Max. Rating : 9V Vin Operating Range : 2.5~7V
2.4	2010/05/18	3	Add Output 3.0V
2.5	2010/07/28	3	Add Output 1.5V, 2.5V
2.6	2010/10/20	3	Add Output 1.5V
2.7	2014/05/22	2	Revised company address