



PAM8402

2 Watt Class-D Audio Amplifiers with Enable

Description

The PAM8402 is 2 Watt per channel, 14-pin, stereo class D audio amplifier, which offers low THD+N (0.10%), allowing it to produce high-quality sound reproduction.

The PAM8402 runs off of a 5 Volt supply at much higher efficiencies than their class AB cousins, making it ideal for many portable applications.

The PAM8402 only requires very few external components (as few as three tiny capacitors), results in significant cost and board space savings.

The PAM8202 is available in a SOP14 package.

Features

- **2 Watts @ 10% THD per channel output into a 8Ω load at 5V**
- **Support speakers or earphone (6Ω to 32Ω).**
- **Superior low noise without input.**
- **Supply voltage: From 2.5V to 6 V.**
- **85% efficiency above.**
- **With Enable Function.**
- **Short Circuit Protection.**
- **Small package outlines: SOP14**
- **Less output capacitor and inductor to save the space and cost.**
- **Low THD+N**
- **Low Quiescent current**

Applications

- Notebook computers.
- PDAs.
- Portable DVD players, game machines.
- Cellular phones/speaker phones.
- MP3 or PMP players.
- Portable speakers, USB speaker.
- LCD monitor / TVs.

PAM8402 Block Diagram

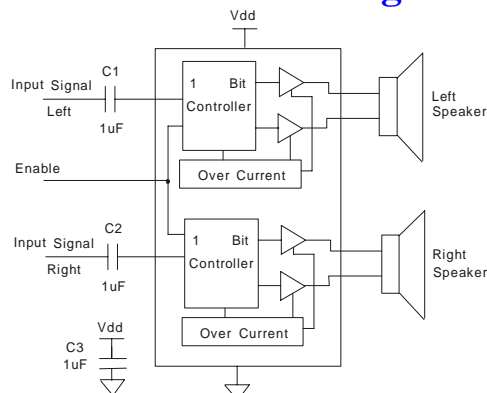

PAM8402 Pin Assignment

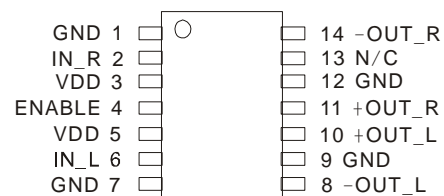

THD+N vs. Frequency (8Ω, 500mW)

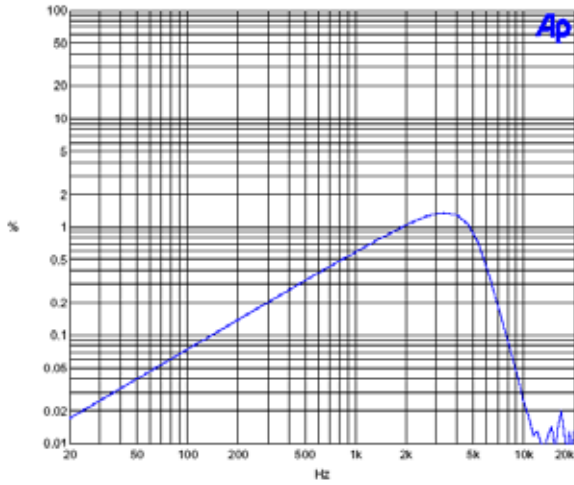

THD+N vs. Output Power (8 Ohms, 1 kHz, Vdd=2.5V to 6V)

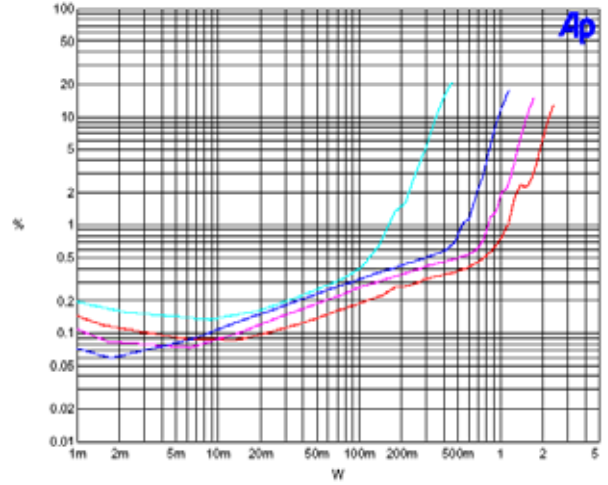

With an 8-ohm load:

Vdd:	2.5V	4.0V	5.0V	6.0V
Output Watt:	0.35W	0.92W	1.6W	2.2W

Efficiency vs. Output power (8 Ohms, 1kHz, Vdd = 5V)

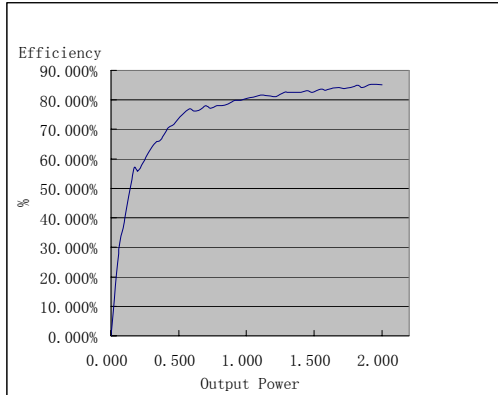

Package Description PAM8402

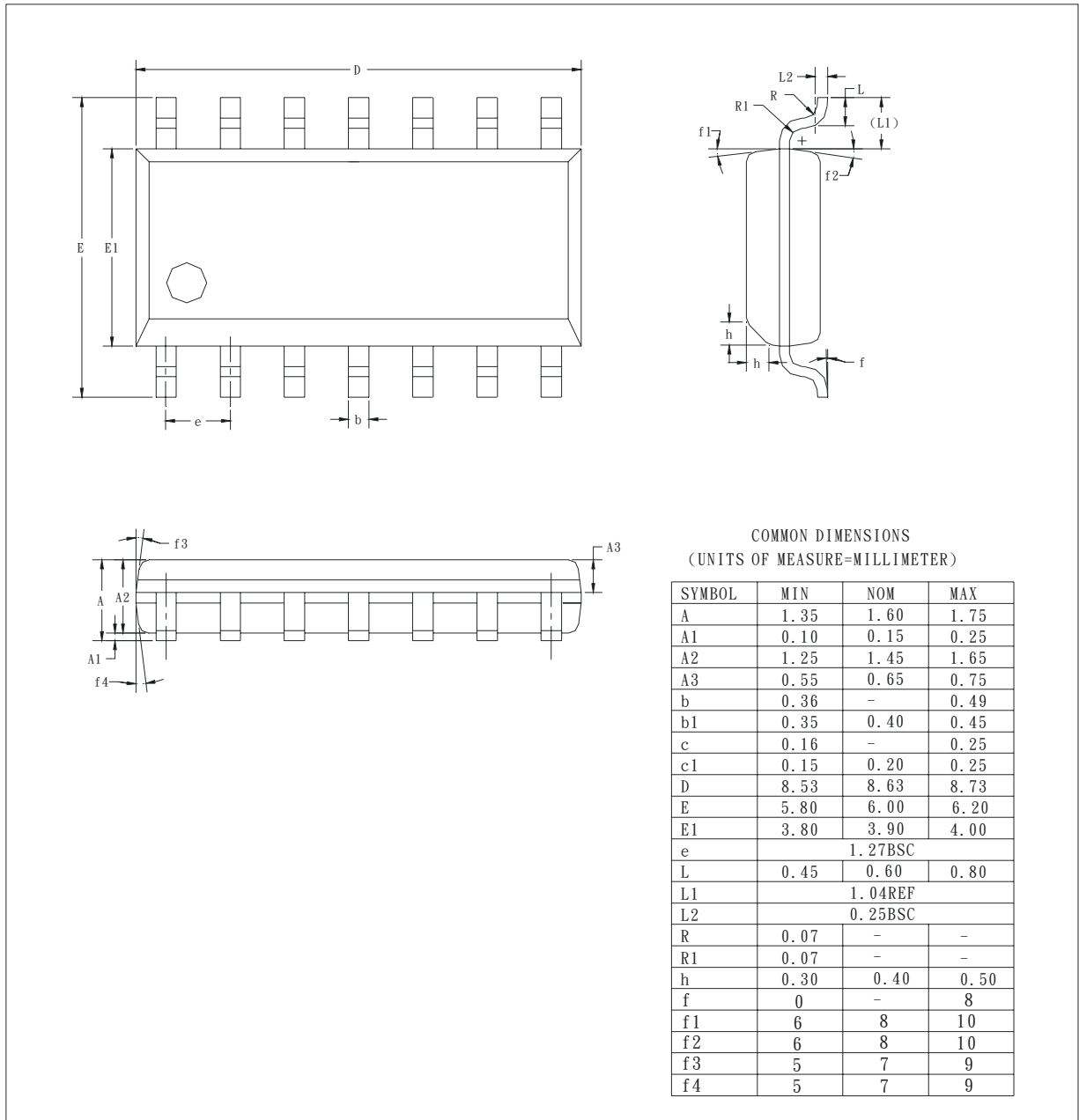

Note: Package outline exclusive of mold flash and metal burr.