

PRELIMINARY

SINGLE-SUPPLY DUAL HIGH CURRENT OPERATIONAL AMPLIFIER

DESCRIPTION

AA3414 is a high output current, high output voltage swing and high gain dual operational amplifier capable of driving 70mA. The IC is available in 8-pin TSSOP (AA3414A) and 8-pin SOP (AA3414S) package.

FEATURES

- Bipolar Technology
- Provided in TSSOP-8, SOP-8 package
- Single Power Supply
- Wide Operating Voltage from 3V ~ 15V
- Capable of driving 70mA
- 1.0V/us Slew Rate

APPLICATIONS

- Audio
- Digital Photo Frame
- Portable Digitals

BLOCK DIAGRAM

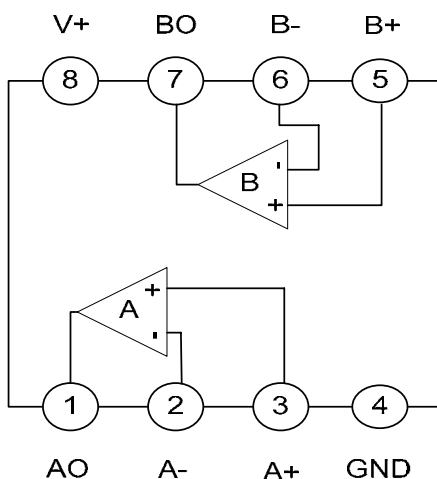

PRELIMINARY

SINGLE-SUPPLY DUAL HIGH CURRENT OPERATIONAL AMPLIFIER

■ **PIN DESCRIPTIONS**

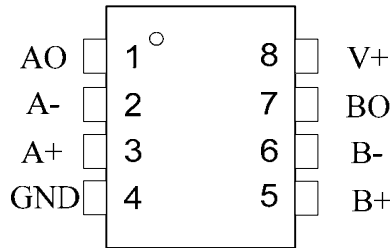

TOP VIEW

PIN NO.	PIN NAME	PIN FUNCTION
1	AO	Amplifier A Output
2	A-	Amplifier B Invert Input
3	A+	Amplifier A Non-Invert Input
4	GND	Ground
5	B+	Amplifier B Non-Invert Input
6	B-	Amplifier B Invert Input
7	BO	Amplifier B Output
8	V+	Wide Operating Voltage from 3V to 15V

■ **ABSOLUTE MAXIMUM RATINGS**

TA=25°C

PARAMETER	SYMBOL	RATING	UNIT
Supply Voltage	VCC	-0.3 ~ +18(or±9V)	V
Operating Ambient Temperature	TA	-40 ~ +85	°C
Storage Temperature	TS	-40 ~ +125	°C

NOTE: Stress above those listed under “Absolute Maximum Rating” may cause device permanent damage. This stress-rating only factor and functional operation of the device at these or any other conditions above those indicated in the operational section of this specification is not implied. Exposure to absolute maximum rating conditions for an extending period of time may affect the reliability of the device.



PRELIMINARY SINGLE-SUPPLY DUAL HIGH CURRENT OPERATIONAL AMPLIFIER

■ **ELECTRICAL CHARACTERISTICS**

TA = 25°C, V+=8.6V

SYMBOL	PARAMETER	CONDITIONS	LIMITS			UNIT
			MIN	TYP	MAX	
V+	Operating Voltage		--	--	15	V
Icc	Supply Current	RL = ∞	3	4	5	mA
GB	Gain Bandwidth		--	1.3	--	MHz
VIO	Input Offset Voltage	RS = 0	--	2	5	mV
IIO	Input Offset Current		--	5	100	nA
Av	Large Signal Voltage Gain	RL = 2KΩ	88	100	--	dB
VICM	Input Common Voltage Range		V+ - 2	--	--	V
VOM1	Maximum Output Voltage Swing 1	RL ≥ 2KΩ, V+ = 5V	3.5	--	--	V
VOM2	Maximum Output Voltage Swing 2	IO = 70mA, V+ = 5V	3.2	--	--	V
CMR	Common Mode Rejection Ratio		80	90	--	dB
SVR	Supply Voltage Rejection Ratio		80	90	--	dB
SR	Slew Rate		--	1.0	--	V/us

■ **ORDERING INFORMATION**

ORDER NO.	PACKAGE	PACKING	ONE REEL Q'TY	MARK CHART	
AA3414A	TSSOP 8L	Tape & Reel	3,000ea	<table border="1" style="margin-left: auto; margin-right: auto;"> <tr> <td style="text-align: center;">3414 XXXX A</td> </tr> </table>	3414 XXXX A
3414 XXXX A					
AA3414S	SOP 8L	Tape & Reel	3,000ea	<table border="1" style="margin-left: auto; margin-right: auto;"> <tr> <td style="text-align: center;">3414 XXXX S</td> </tr> </table>	3414 XXXX S
3414 XXXX S					

PACKAGE DIMENSIONS

TSSOP 8L

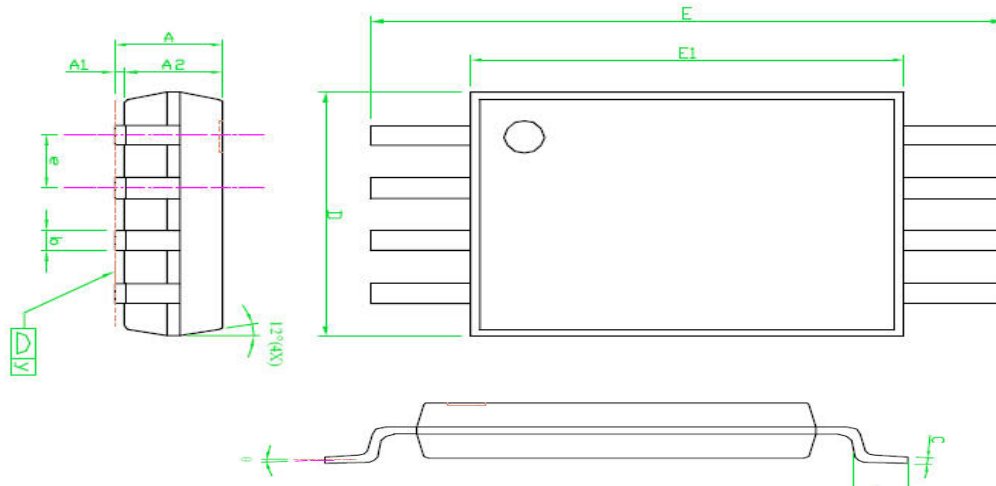

SYMBOLS	DIMENSIONS IN MILLIMETERS			DIMENSIONS IN INCHES		
	MIN	NOM	MAX	MIN	NOM	MAX
A	---	---	1.20	---	---	0.048
A1	0.05	---	0.15	0.002	---	0.006
A2	0.80	1.00	1.05	0.031	0.039	0.041
b	0.19	---	0.30	0.007	---	0.012
C	0.09	---	0.20	0.004	---	0.008
D	2.90	3.00	3.10	0.114	0.118	0.122
E	6.20	6.40	6.60	0.244	0.252	0.260
E1	4.30	4.40	4.50	0.169	0.173	0.177
e	---	0.65	---	---	0.026	---
L	0.45	0.60	0.75	0.018	0.024	0.030
y	---	---	0.10	---	---	0.004
θ	0°	---	8°	0°	---	8°

NOTES:

1. Package body sizes exclude mold flash protrusions or gate burrs
2. Tolerance ± 0.1 mm (4 mil) unless otherwise specified
3. Coplanarity: 0.1 mm
4. Controlling dimension is millimeter whereas converted inch dimensions are not necessarily exact
5. Followed from jedec mo-153

PRELIMINARY

SINGLE-SUPPLY DUAL HIGH CURRENT OPERATIONAL AMPLIFIER

SOP 8L

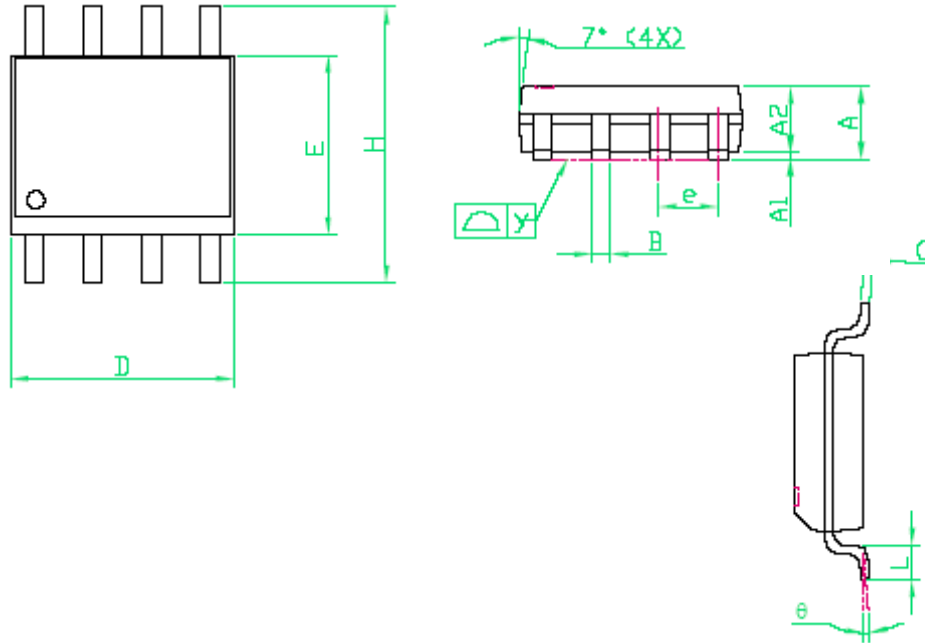

SYMBOLS	DIMENSIONS IN MILLIMETERS			DIMENSIONS IN INCHES		
	MIN	NOM	MAX	MIN	NOM	MAX
A	1.35	1.60	1.75	0.053	0.063	0.069
A1	0.10	---	0.25	0.004	---	0.010
A2	---	1.45	---	---	0.057	---
b	0.33	---	0.51	0.013	---	0.020
C	0.19	---	0.25	0.007	---	0.010
D	4.80	---	5.00	0.189	---	0.197
E	3.80	---	4.00	0.150	---	0.157
e	---	1.27	---	---	0.050	---
H	5.80	---	6.20	0.228	---	0.244
L	0.40	---	1.27	0.016	---	0.050
y	---	---	0.10	---	---	0.004
θ	0°	---	8°	0°	---	8°

NOTES:

1. Package body sizes exclude moldflash protrusions or gate burns.
2. Tolerance ± 0.1 mm (4 mil) unless otherwise specified
3. Coplanarity: 0.1 mm
4. Controlling dimension is millimeter converted inch dimensions are not necessarily exact
5. Followed from JEDEC MS-012