



High Speed CMOS Logic – 54HC240

Octal 3-State Inverting Buffer / Line Driver / Line Receiver in bare die form

Rev 1.1
30/11/21

Description

The 54HC240 is produced on a 2.5µm 5V CMOS process combining high speed LSTTL performance with CMOS low power. The device can be used as two 4-bit buffers or one 8-bit buffer & features inverting inputs with two output enables, each controlling four of the 3-state outputs. The device improves performance & density in clock drivers, 3-state memory address drivers & bus orientated transmitters and receivers. Device inputs are compatible with standard CMOS outputs; with pull-up resistors, they are compatible with LSTTL outputs. All inputs are equipped with protection circuits against static discharge & transient excess voltage.

Features:

- Output Drive Capability: 15 LSTTL Loads
- Low Input Current: 1µA
- Outputs directly interface CMOS, NMOS and TTL
- Operating Voltage Range: 2V to 6V
- CMOS High Noise Immunity
- Function compatible with 54LS240
- Lower power alternative to Bipolar or BiCMOS logic
- Full military temperature range.

Ordering Information

The following part suffixes apply:

- No suffix - MIL-STD-883 /2010B Visual Inspection
- "H" - MIL-STD-883 /2010B Visual Inspection
+ MIL-PRF-38534 Class H LAT
- "K" - MIL-STD-883 /2010A Visual Inspection (Space)
+ MIL-PRF-38534 Class K LAT

LAT = Lot Acceptance Test.

For further information on LAT process flows see below.

www.siliconsupplies.com/quality/bare-die-lot-qualification

Die Dimensions in µm (mils)

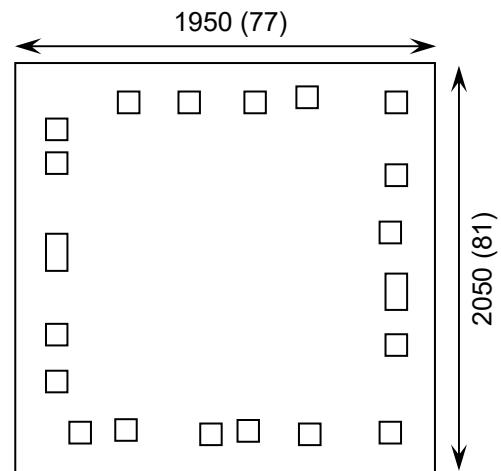

Supply Formats:

- Default – Die in Waffle Pack (100 per tray capacity)
- Sawn Wafer on Tape – On request
- Unsawn Wafer – On request
- Die Thickness <=> 350µm(14 Mils) – On request
- Assembled into Ceramic Package – On request

Mechanical Specification

Die Size (Unsawn)	1950 x 2050 77 x 81	µm mils
Minimum Bond Pad Size	106 x 106 4.17 x 4.17	µm mils
Die Thickness	350 (±20) 13.78 (±0.79)	µm mils
Top Metal Composition	Al 1%Si 1.1µm	
Back Metal Composition	N/A – Bare Si	





High Speed CMOS Logic – 54HC240

Rev 1.1
30/11/21

Pad Layout and Functions

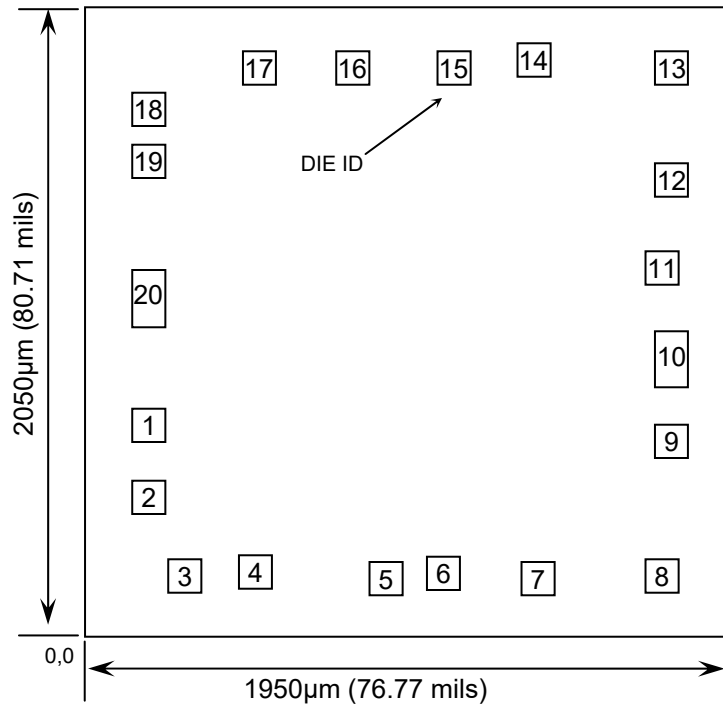

PAD	FUNCTION	COORDINATES (mm)	
		X	Y
1	$\overline{1OE}$	0.152	0.636
2	1A1	0.152	0.396
3	$\overline{2Y4}$	0.300	0.142
4	1A2	0.470	0.152
5	$\overline{2Y3}$	0.868	0.132
6	1A3	1.038	0.152
7	$\overline{2Y2}$	1.330	0.132
8	1A4	1.709	0.142
9	$\overline{2Y1}$	1.729	0.578
10	GND	1.729	0.812
11	2A1	1.699	1.149
12	1Y4	1.729	1.438
13	$\overline{2A2}$	1.719	1.804
14	1Y3	1.301	1.824
15	$\overline{2A3}$	1.062	1.804
16	1Y2	0.758	1.804
17	$\overline{2A4}$	0.468	1.804
18	1Y1	0.142	1.662
19	$\overline{2OE}$	0.142	1.489
20	$\overline{V_{CC}}$	0.142	1.005

CONNECT CHIP BACK TO V_{CC}

Logic Diagram

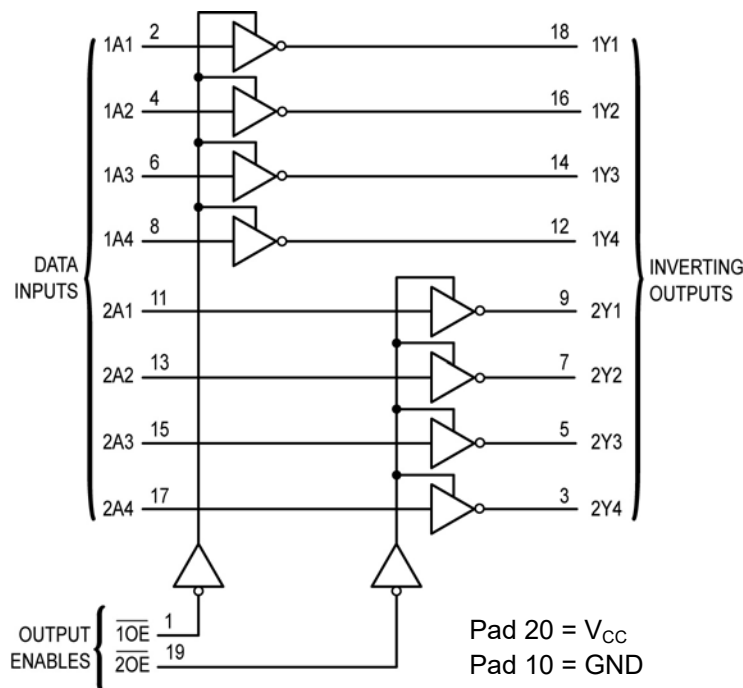

Truth Table

INPUTS		OUTPUTS
$\overline{1OE}$ $\overline{2OE}$	1A, 2A	1Y, 2Y
L	L	H
L	H	L
H	X	Z

H = High level (steady state)
L = Low level (steady state)
X = Don't care, Z = High impedance





Pad Descriptions

ADDRESS INPUTS

1A1, 1A2, 1A3, 1A4, 2A1, 2A2, 2A3, 2A4
(Pads 2, 4, 6, 8, 11, 13, 15, 17)

Data input pins. Data on these pins appear in inverted form on the corresponding Y outputs, when the outputs are enabled.

CONTROL INPUTS

1OE, 2OE (Pads 1, 19)

Output enables (active–low). When a low level is applied to these pins, the outputs are enabled and the devices function as inverters. When a high level is applied, the outputs assume the high impedance state.

OUTPUTS

1Y1, 1Y2, 1Y3, 1Y4, 2Y1, 2Y2, 2Y3, 2Y4
(Pads 18, 16, 14, 12, 9, 7, 5, 3)

Device outputs. Depending upon the state of the output enable pins, these outputs are either inverting outputs or high–impedance outputs.

Absolute Maximum Ratings¹

PARAMETER	SYMBOL	VALUE	UNIT
DC Supply Voltage (Referenced to GND)	V_{CC}	-0.5 to +7.0	V
DC Input Voltage (Referenced to GND)	V_{IN}	-1.5 to $V_{CC} + 1.5$	V
DC Output Voltage (Referenced to GND)	V_{OUT}	-0.5 to $V_{CC} + 0.5$	V
DC Input Current, per pin	I_{IN}	±20	mA
DC Output Current, per pin	I_{OUT}	±35	mA
DC V_{CC} or GND Current, per pin	I_{CC}	±75	mA
Power Dissipation in Still Air ²	P_D	750	mW
Storage Temperature Range	T_{STG}	-65 to 150	°C

1. Operation above the absolute maximum rating may cause device failure. Operation at the absolute maximum ratings, for extended periods, may reduce device reliability. 2. Measured in plastic DIP package, results in die form are dependent on die attach and assembly method.

Recommended Operating Conditions³ (Voltages referenced to GND)

PARAMETER	SYMBOL	MIN	MAX	UNITS	
DC Supply Voltage	V_{CC}	2	6	V	
DC Input or Output Voltage	V_{IN}, V_{OUT}	0	V_{CC}	V	
Operating Temperature Range	T_J	-55	+125	°C	
Input Rise or Fall rate	$V_{CC} = 4.5V$	t_r, t_f	0	1000	ns
	$V_{CC} = 5.5V$		0	500	
	$V_{CC} = 6.0V$		0	400	

3. This device contains protection circuitry to guard against damage due to high static voltages or electric fields. However, precautions must be taken to avoid applications of any voltage higher than maximum rated voltages to this high-impedance circuit. For proper operation, V_{IN} and V_{OUT} should be constrained to the range $GND \leq (V_{IN} \text{ or } V_{OUT}) \leq V_{CC}$. Unused inputs must always be tied to an appropriate logic voltage level (e.g., either GND or V_{CC}). Unused outputs must be left open.





High Speed CMOS Logic – 54HC240

Rev 1.1
30/11/21

DC Electrical Characteristics (Voltages Referenced to GND)

PARAMETER	SYMBOL	V _{CC}	CONDITIONS	LIMITS			UNITS
				25°C	85°C	FULL RANGE ⁴	
Minimum High-Level Input Voltage	V _{IH}	2.0V	V _{OUT} = V _{CC} -0.1V I _{OUT} ≤ 20μA	1.5	1.5	1.5	V
		4.5V		3.15	3.15	3.15	
		6.0V		4.2	4.2	4.2	
Maximum Low-Level Input Voltage	V _{IL}	2.0V	V _{OUT} = 0.1V I _{OUT} ≤ 20μA	0.5	0.5	0.5	V
		4.5V		1.35	1.35	1.35	
		6.0V		1.8	1.8	1.8	
Minimum High-Level Output Voltage	V _{OH}	2.0V	V _{IN} = V _{IH} I _{OUT} ≤ 20μA	1.9	1.9	1.9	V
		4.5V		4.4	4.4	4.4	
		6.0V		5.9	5.9	5.9	
		4.5V	V _{IN} = V _{IH} I _{OUT} ≤ 6.0mA	3.98	3.84	3.70	
		6.0V	V _{IN} = V _{IH} I _{OUT} ≤ 7.8mA	5.48	5.34	5.20	
Maximum Low-Level Output Voltage	V _{OL}	2.0V	V _{IN} = V _{IL} I _{OUT} ≤ 20μA	0.1	0.1	0.1	V
		4.5V		0.1	0.1	0.1	
		6.0V		0.1	0.1	0.1	
		4.5V	V _{IN} = V _{IL} I _{OUT} ≤ 6.0mA	0.26	0.33	0.40	
		6.0V	V _{IN} = V _{IL} I _{OUT} ≤ 7.8mA	0.26	0.33	0.40	
Maximum Input Leakage Current	I _{IN}	6.0V	V _{IN} = V _{CC} or GND	±0.1	±1.0	±1.0	μA
Maximum 3-State Leakage Current	I _{OZ}	6.0V	High-Impedance State, V _{IN} = V _{IL} or V _{IH} , V _{OUT} = V _{CC} or GND	±0.5	±5.0	±10.0	μA
Maximum Quiescent Supply Leakage Current	I _{CC}	6.0V	V _{IN} = V _{CC} or GND I _{OUT} = 0μA	4	40	160	μA

4. -55°C ≤ T_J ≤ +125°C





High Speed CMOS Logic – 54HC240

Rev 1.1
30/11/21

AC Electrical Characteristics⁵

PARAMETER	SYMBOL	V _{CC}	CONDITIONS	LIMITS			UNITS
				25°C	85°C	FULL RANGE ⁴	
Maximum Propagation Delay, Input A to Output Y (Figure 1)	t _{PLH} , t _{PHL}	2.0V	C _L = 50pF, Input t _r = t _f = 6ns	80	100	120	ns
		4.5V		16	20	24	
		6.0V		14	17	20	
Maximum Propagation Delay, OE to Output Y (Figure 2, 3)	t _{PZL} , t _{PHZ}	2.0V	C _L = 50pF, Input t _r = t _f = 6ns	110	140	165	ns
		4.5V		22	28	33	
		6.0V		19	24	28	
Maximum Propagation Delay, OE to Output Y (Figure 2, 3)	t _{PZL} , t _{PZH}	2.0V	C _L = 50pF, Input t _r = t _f = 6ns	110	140	165	ns
		4.5V		22	28	33	
		6.0V		19	24	28	
Maximum Output Rise and Fall Time, Any Output (Figure 1)	t _{TLH} , t _{THL}	2.0V	C _L = 50pF, Input t _r = t _f = 6ns	60	75	90	ns
		4.5V		12	15	18	
		6.0V		10	13	15	
Maximum Input Capacitance	C _{IN}	-	-	10	10	10	pF
Maximum 3-State Output Input (High-Z)	C _{OUT}	-	-	15	15	15	pF
Power Dissipation Capacitance ⁶	C _{PD}	-	T _J = 25°C, V _{CC} = 5.0V	TYPICAL			pF
				32			

5. Not production tested in die form, characterized by chip design.

6. Used to determine the no-load dynamic power consumption: $P_D = C_{PD} V_{CC}^2 f + I_{CC} V_{CC}$.

Switching Waveforms

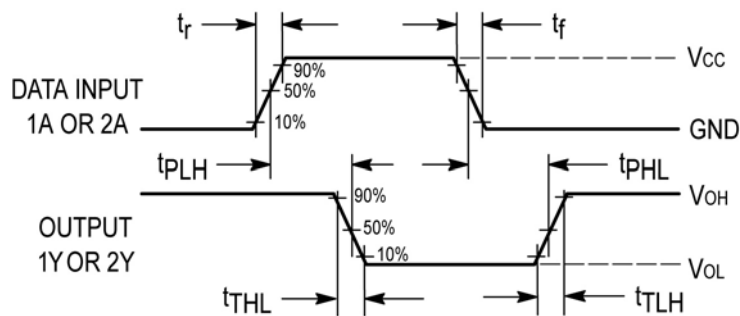

Figure 1 – Propagation Delay - Input 1A or 2A to Output 1Y or 2Y





Switching Waveforms continued

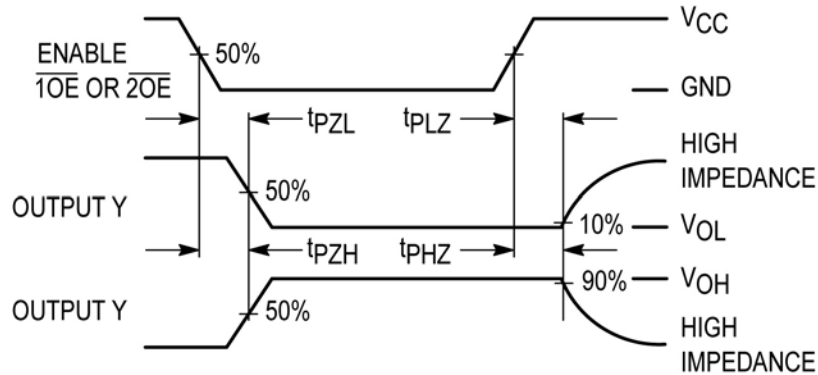
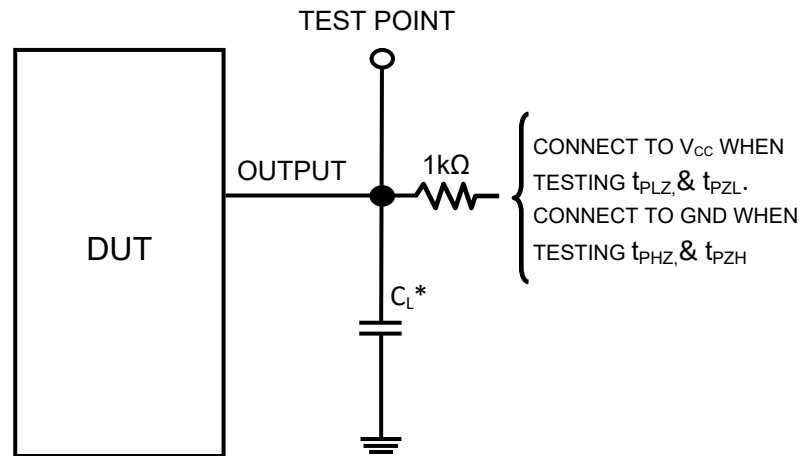

Figure 2 – Propagation Delay - Output Enable to Output 1Y or 2Y

Test Circuit



* Includes all probe and jig capacitance

Figure 3

DISCLAIMER: The information given in this document shall in no event be regarded as a guarantee of conditions or characteristics. With respect to any examples or hints given herein, any typical values stated herein and/or any information regarding the application of the device, Silicon Supplies Ltd hereby disclaims any and all warranties and liabilities of any kind.

LIFE SUPPORT POLICY: Silicon Supplies Ltd components may be used in life support devices or systems only with the express written approval of Silicon Supplies Ltd, if a failure of such components can reasonably be expected to cause the failure of that life support device or system or to affect the safety or effectiveness of that device or system. Life support devices or systems are intended to be implanted in the human body or to support and/or maintain and sustain and/or protect human life. If they fail, it is reasonable to assume that the health of the user or other persons may be endangered.

