

Rack-mounted DCS Signal Conditioners 18-RACK

WATT TRANSDUCER

Functions & Features

- Providing two DC output signals in proportion to AC active power
- Measuring bidirectional power flow
- DC output containing little ripple is ideal for computer input
- "Time division multiplication" method accepts distorted waveforms

Typical Applications

- Centralized monitoring and control of power management system in a manufacturing facility or building
- SCR - Silicon Controlled Rectifier

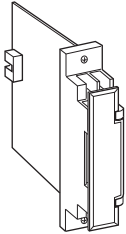

MODEL: 18WT-[1][2]66-R

ORDERING INFORMATION

- Code number: 18WT-[1][2]66-R
- Specify a code from below for each of [1] and [2].
(e.g. 18WT-1166-R)
- Calibration range (e.g. 0 - 1000 W)
 - VT ratio, CT ratio (e.g. VT 3300/110 V, CT 250/5 A)

[1] CONFIGURATION

- 1: 3-phase / 3-wire
- 2: Single-phase / 2-wire
- 3: Single-phase / 3-wire

[2] INPUT (unbalanced load)

- 1: 110 V / 5 A AC
 - 2: 110 V / 1 A AC
 - 3: 220 V / 1 A AC
 - 4: 220 V / 5 A AC
- A: 100 V / 200 V / 1 A AC (single-phase / 3-wire)
B: 100 V / 200 V / 5 A AC (single-phase / 3-wire)

OUTPUT 1

Voltage

6: 1 - 5 V DC (Load resistance 5000 Ω min.)

OUTPUT 2

Voltage

6: 1 - 5 V DC (Load resistance 5000 Ω min.)

POWER INPUT

DC Power

R: 24 V DC

(Operational voltage range 24 V ±10 %, ripple 10 %p-p max.)

GENERAL SPECIFICATIONS

Construction: Rack-mounted; terminal access via screw terminals on the front and connector on the rear; terminal cover provided

Connection

Input: M3.5 screw terminals (torque 0.8 N·m)

Output 1: Connector

Output 2: Connector

Power input: Supplied from connector

Screw terminal: Nickel-plated steel

Isolation: Voltage input to current input to output 1 to output 2 to power

Overrange output: Approx. -10 to +120 % at 1 - 5 V

Zero adjustment: -5 to +5 % (front)

Span adjustment: 95 to 105 % (front)

INPUT SPECIFICATIONS

Frequency: 50 or 60 Hz

• **Current Input**

Operational range: 0 - 120 % of rating

Overload capacity: 1000 % of rating for 3 sec., 200 % for 10 sec., 120 % continuous

• **Voltage Input**

Operational range: 0 - 120 % of rating

Overload capacity: 150 % of rating for 10 sec., 120 % continuous

■ **How To Determine Wattage Range**

Calibration Range [W] = Measuring Wattage ÷ ((VT Ratio) × (CT Ratio))

Check that the required calibration range is within the available range in the table. Specify this range when ordering.

[example]

3-phase / 3-wire, measuring wattage 750 kW,

VT 3300/110 V, CT 250/5 A

$750 \times 10^3 [W] \div ((3300 \div 110) \times (250 \div 5)) = 0 - 500 [W]$

• **3-phase / 3-wire**

INPUT	STD.RANGE	AVAILABLE RANGE	BURDEN (VA)	
			VOLT.	CURR.
110V/1A	±200W	±100 - ±240W	0.2	0.1/phase
110V/5A	±1000W	±500 - ±1200W		/phase
220V/1A	±400W	±200 - ±480W	0.4	0.1/phase
220V/5A	±2000W	±1000 - ±2400W		/phase

• **Single-phase / 2-wire**

INPUT	STD.RANGE	AVAILABLE RANGE	BURDEN (VA)	
			VOLT.	CURR.
110V/1A	±100W	±50 - ±120W	0.2	0.1/phase
110V/5A	±500W	±250 - ±600W		/phase
220V/1A	±200W	±100 - ±240W	0.4	0.1/phase
220V/5A	±1000W	±500 - ±1200W		/phase

• **Single-phase / 3-wire**

INPUT	STD.RANGE	AVAILABLE RANGE	BURDEN (VA)	
			VOLT.	CURR.
200V/1A	±200W	±100 - ±240W	0.2	0.1/phase
200V/5A	±1000W	±500 - ±1200W		/phase

OUTPUT SPECIFICATIONS

■ **OPERATION DIAGRAM (example)**

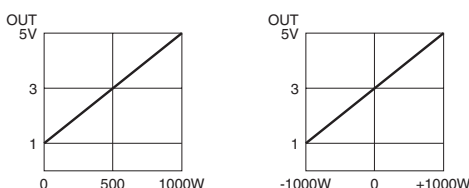

INSTALLATION

Current consumption: Approx. 80 mA

Operating temperature: -5 to +55°C (23 to 131°F)

Operating humidity: 30 to 90 %RH (non-condensing)

Mounting: Standard Rack 18BXx or 18KBXx

Weight: 200 g (0.44 lb)

PERFORMANCE in percentage of span

Accuracy: ±0.5 %

Temp. coefficient: ±0.05 %/°C (±0.03 %/°F)

Response time: ≤ 1 sec. (0 - 90 %)

Ripple: 0.5 %p-p max. (50/60 Hz)

Line voltage effect: ±0.1 % over voltage range

Insulation resistance: ≥ 100 MΩ with 500 V DC

Dielectric strength: 2000 V AC @ 1 minute

(voltage input to current input to output 1 or output 2 or power)

500 V AC @ 1 minute (output 1 to output 2 to power)

2000 V AC @ 1 minute (input or output or power to ground)

CONNECTION DIAGRAM

3-PHASE/3-WIRE

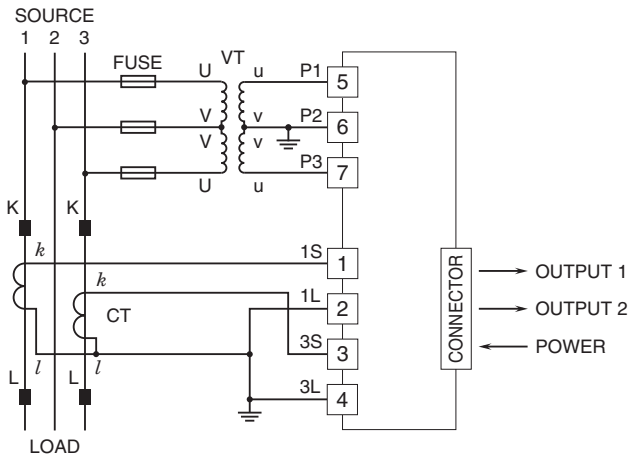

SINGLE-PHASE/2-WIRE

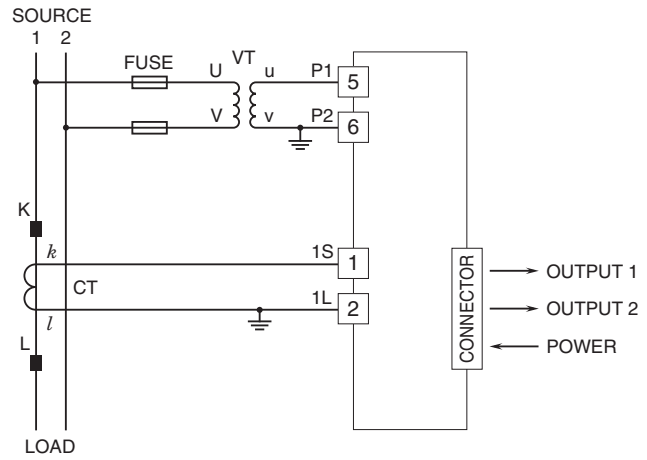

SINGLE-PHASE/3-WIRE

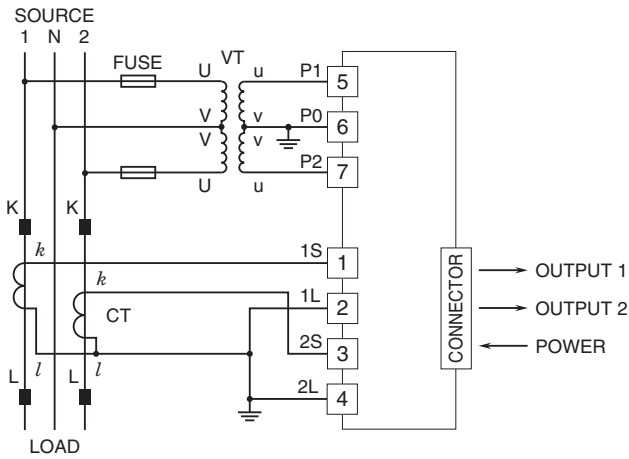

EXTERNAL DIMENSIONS unit: mm (inch)

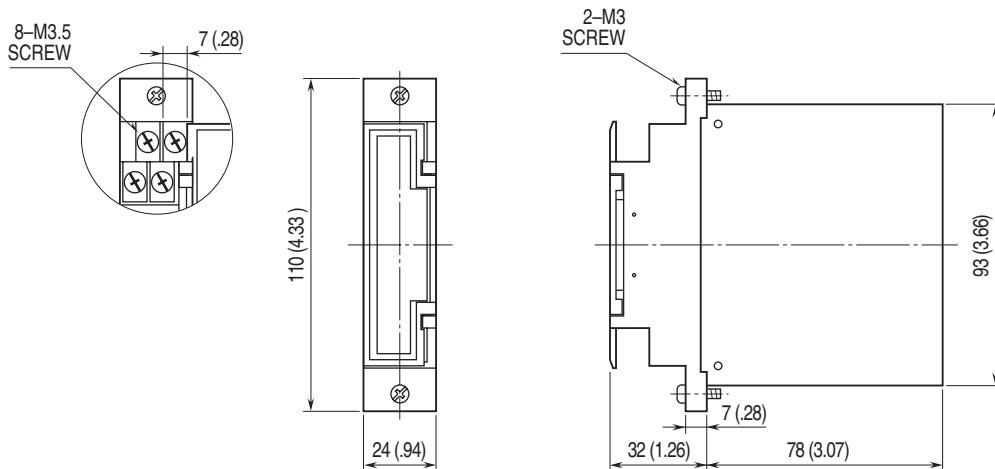

TERMINAL ASSIGNMENTS

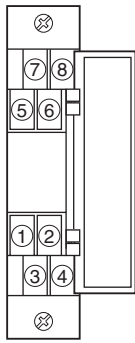

Specifications are subject to change without notice.