



FEATURES

- ◆ Ultra-wide 2:1 input range
- ◆ DIP-16 package
- ◆ Efficiency up to 81%
- ◆ Temperature range -40°C to +85°C
- ◆ HMTBF > 1,000,000 Hours
- ◆ Low Ripple and Noise
- ◆ Short Circuit Protection
- ◆ I/O isolation 1500 VDC
- ◆ Complies with EN55022 Class A
- ◆ Fully RoHS compliant
- ◆ UL 94 V-0 Package Material
- ◆ Internal SMD Construction

MODEL SELECTION

WRA^① 24^② 05^③ Y^④ GD^⑤-2W(119)^⑥

- ① Product Series
- ② Input Voltage
- ③ Output Voltage
- ④ Wide (2:1) Input Range
- ⑤ DIP16 Package Style
- ⑥ Rated Power(Output current)

DESCRIPTION

The WRA-YGD-2W & WRB-YGD-2W Series power modules are low-profile dc-dc converters that operate over input voltage of 4.5-9VDC, 9-18VDC, 18-36VDC and 36-75VDC which provide precisely regulated output voltages of 3.3V, 5V, 12V, 15V, ±5V, ±12V and ±15VDC.

The WRA-YGD-2W & WRB-YGD-2W Series is an excellent for data communication equipments, mobile battery driven equipments, distributed power systems, telecommunication equipments, mixed analog/machine control equipments, computer peripheral systems and industrial robot systems.

The modules have a maximum power rating of 2W and a typical full-load efficiency of 81%, continuous short circuit, 30mV output ripple, built-in filtering for both input and output minimize the need for external filtering.



Absolute Maximum Ratings

Parameter	Min.	Max.	Unit.	
Input Sure Voltage (1000 mS)	5VDC Input Models	-0.7	11	VDC
	12VDC Input Models	-0.7	25	VDC
	24VDC Input Models	-0.7	50	VDC
	48VDC Input Models	-0.7	100	VDC
Lead Temperature(1.5mm from case for 10 Sec.)	---	260	°C	
Internal Power Dissipation	---	1,800	mW	

Environmental Specifications

Parameter	Conditions	Min.	Max.	Unit.
Operating Temperature	Ambient	-40	+65	°C
Operating Temperature	Case	-40	+90	°C
Storage Temperature		-40	+125	°C
Humidity		---	95	%
Cooling	Free-Air Convection			
Conducted	EN55022 Class A			

Exceeding the absolute maximum ratings of the unit could cause damage.
These are not continuous operating ratings.

Capacitive Load

Models by Vout	3.3V	5V	12V	15V	±5V *	±12V *	±15V*	Unit
Maximum Capacitive Load	2200	1000	110	470	100	20	47	uF

* For each output

Input Fuse Selection Guide

5V Input Models	12V Input Models	24V Input Models	48V Input Models
1000mA Slow - Blow Type	500mA Slow - Blow Type	250mA Slow - Blow Type	120mA Slow - Blow Type

SELECTION GUIDE

Model Number	Input Voltage	Output Voltage	Output Current		Input Current		Reflected Ripple Current % (Max.)	Efficiency
	VDC	VDC	Max mA	Min mA	@Max. Load mA (Typ.)	@No Load mA (Typ.)		@Max. Load % (Typ.)
WRB0503YGD-500	5 (4.5 ~ 9)	3.3	500	125	471	40	100	70
WRB0505YGD-2W		5	400	100	548	40	100	73
WRB0512YGD-2W		12	167	42	534	40	100	75
WRB0515YGD-2W		15	134	33	582	40	100	73
WRA0505YGD-2W		±5	±200	±50	667	40	100	64
WRA0512YGD-2W		±12	±83	±21	615	40	100	69
WRA0515YGD-2W		±15	±67	±17	598	40	100	71
WRB1203YGD-500	12 (9 ~ 18)	3.3	500	125	184	20	25	73
WRB1205YGD-2W		5	400	100	217	20	25	77
WRB1212YGD-2W		12	167	42	209	20	25	80
WRB1215YGD-2W		15	134	33	220	20	25	80
WRA1205YGD-2W		±5	±200	±50	242	20	25	73
WRA1212YGD-2W		±12	±83	±21	224	20	25	78
WRA1215YGD-2W		±15	±67	±17	226	20	25	78
WRB2403YGD-500	24 (18 ~ 36)	3.3	500	125	96	10	15	72
WRB2405YGD-2W		5	400	100	109	10	15	77
WRB2412YGD-2W		12	167	42	109	10	15	80
WRB2415YGD-2W		15	134	33	108	10	15	81
WRA2405YGD-2W		±5	±200	±50	119	10	15	74
WRA2412YGD-2W		±12	±83	±21	112	10	15	78
WRA2415YGD-2W		±15	±67	±17	110	10	15	80
WRB4803YGD-500	48 (36 ~ 75)	3.3	500	125	49	8	10	71
WRB4805YGD-2W		5	400	100	57	8	10	73
WRB4812YGD-2W		12	167	42	53	8	10	79
WRB4815YGD-2W		15	134	33	55	8	10	79
WRA4805YGD-2W		±5	±200	±50	62	8	10	71
WRA4812YGD-2W		±12	±83	±21	57	8	10	77
WRA4815YGD-2W		±15	±67	±17	57	8	10	77

Input Specifications

Parameter	Mode	Min.	Typ.	Max.	Unit.
Start Voltage	5V Input Models	3.5	4	4.5	VDC
	12V Input Models	4.5	7	9	VDC
	24V Input Models	8	12	18	VDC
	48V Input Models	16	24	36	VDC
Under Voltage Shutdown	5V Input Models	---	3.5	4	VDC
	12V Input Models	---	6.5	8.5	VDC
	24V Input Models	---	11	17	VDC
	48V Input Models	---	22	34	VDC
Reverse Polarity Input Current	All Models	---	---	1	A
Short Circuit Input Power	All Models	---	---	1500	mW
Input Filter	All Models	Pi Filter			

Output Specifications

Parameter	Conditions	Min.	Typ.	Max.	Unit.
Output Voltage Accuracy		---	±1.0	±2.0	%
Output Voltage Balance	Dual Output, Balanced Loads	---	±1.0	±2.0	%
Line Regulation	Vin=Min. to Max	---	±0.3	±0.5	%
Load Regulation	Io=25% to 100%	---	±0.5	±0.75	%
Ripple & Noise (20MHz)		---	30	50	mV P-P
Ripple & Noise (20MHz)	Over Line, Load & Temp	---	---	75	mV P-P
Ripple & Noise (20MHz)		---	---	15	mV rms
Over Power Protection		120	---	---	%
Transient Recovery Time	25% Load Step Change	---	100	300	uS
Transient Response Deviation	25% Load Step Change	---	±3	±5	%
Temperature Coefficient		---	±0.01	±0.02	%/]
Output Short Circuit	Continuous				

General Specifications					
Parameter	Conditions	Min.	Typ.	Max.	Unit.
Isolation Voltage Rated	60 Seconds	1500	---	---	VDC
Isolation Voltage Test	Flash Tested for 1 Second	1650	---	---	VDC
Isolation Resistance	500VDC	1000	---	---	MΩ
Isolation Capacitance	100KHz,1V	---	250	420	pF
Switching Frequency		---	300	---	KHz
MTBF	MIL-HDBK-217F @ 25°C, Ground Benign	1000	---	---	K Hours

Notes :

1. Specifications typical at Ta=+25°C, resistive load, nominal input voltage, rated output current unless otherwise noted.
2. Transient recovery time is measured to within 1%error band for a step change in output load of 75% to 100%.
3. Ripple & Noise measurement bandwidth is 0-20 MHz.
4. These power converters require a minimum output loading to maintain specified regulation.
5. Operation under no-load conditions will not damage these modules; however, they may not meet all specifications listed.
6. All DC/DC converters should be externally fused on the front end for protection.
7. Other input and output voltage may be available, please contact factory.
8. Specifications subject to change without notice

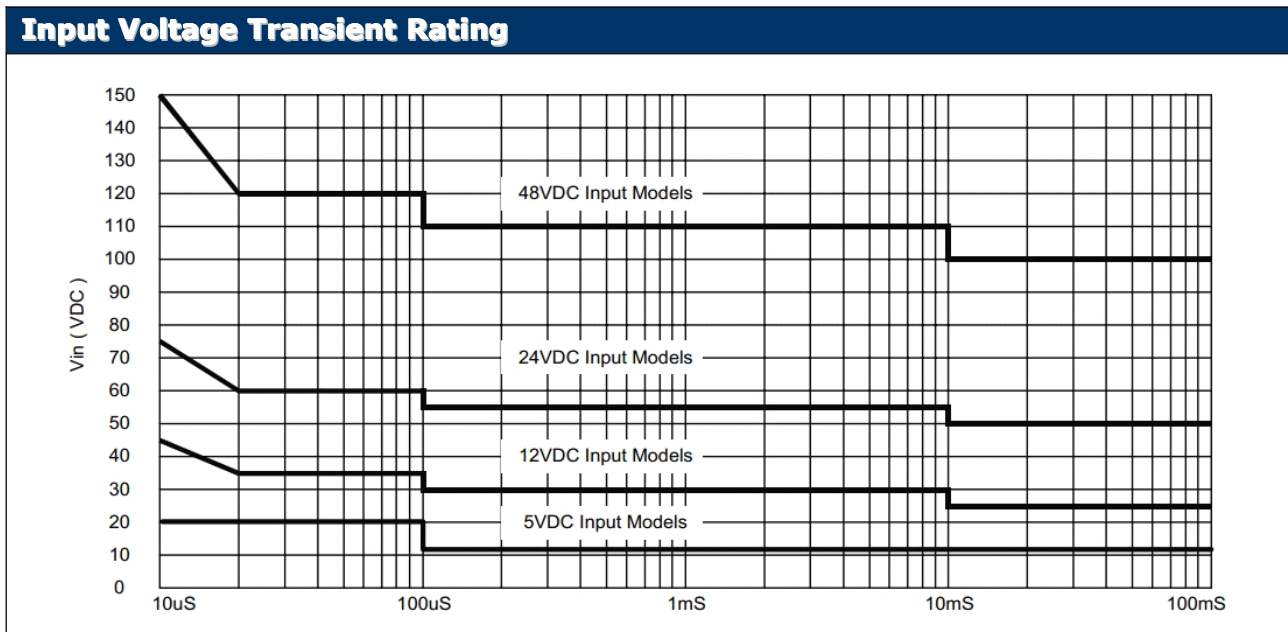
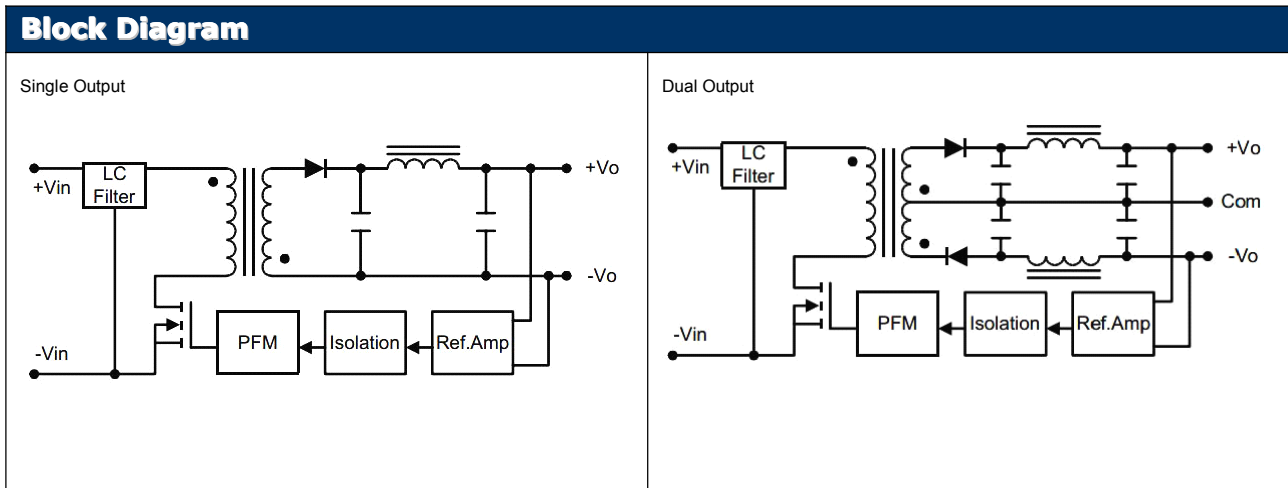

Input Voltage Transient Rating

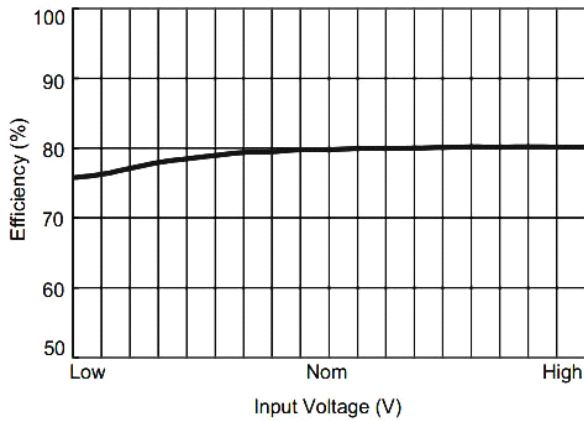

Efficiency vs Input Voltage (Single Output)

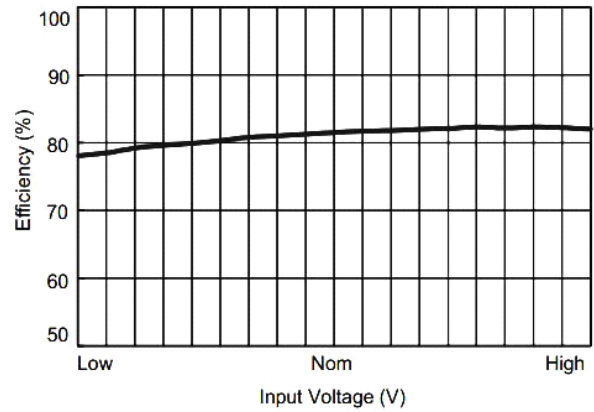

Efficiency vs Input Voltage (Dual Output)

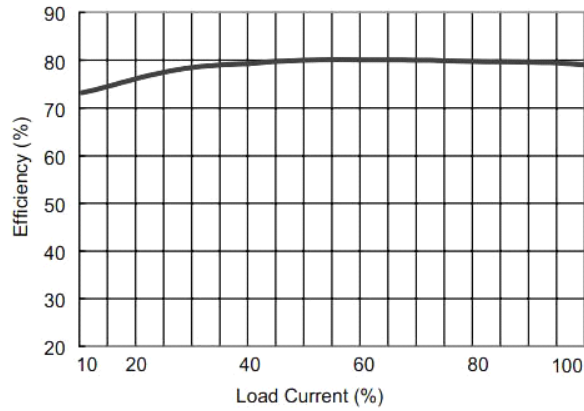

Efficiency vs Output Load (Single Output)

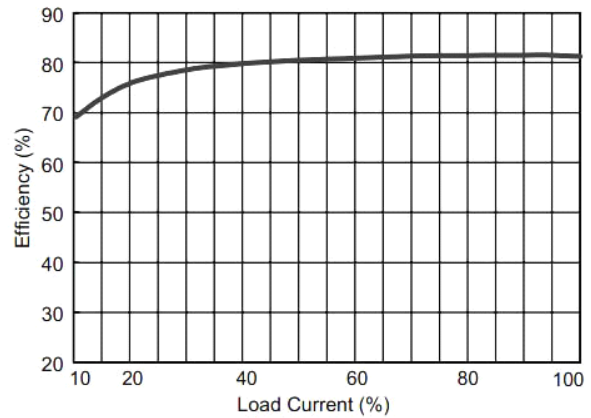

Efficiency vs Output Load (Dual Output)

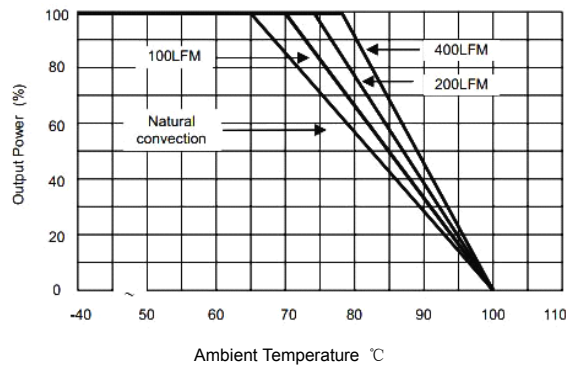

Derating Curve

Test Configurations

Input Reflected-Ripple Current Test Setup

Input reflected-ripple current is measured with an inductor L_{in} (4.7uH) and C_{in} (220uF, ESR < 1.0[at 100 kHz) to simulated source impedance.

Capacitor C_{in} , offsets possible battery impedance.

Current ripple is measured at the input terminals of the module, measurement bandwidth is 0-500KHz.

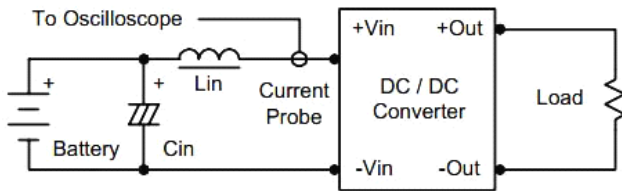

Peak-to-Peak Output Noise Measurement Test

Use a C_{out} 0.47uF ceramic capacitor.

Scope measurement should be made by using a BNC socket, measurement bandwidth is 0-20 MHz. Position the load between 50 mm and 75 mm from the DC/DC Converter.

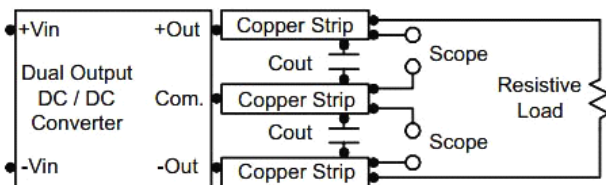
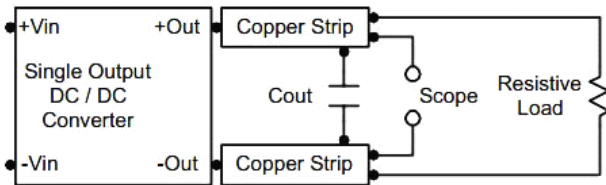

Design & Feature Considerations

Maximum Capacitive Load

The WRA(B)-YGD-2W series has limitation of maximum connected capacitance on the output.

The power module may operate in current limiting mode during start-up, affecting the ramp-up and the startup time.

The maximum capacitance can be found in the data sheet.

To provide protection in a fault (output overload) condition, the unit is equipped with internal current limiting circuitry and can endure current limiting for an unlimited duration. At the point of current-limit inception, the unit shifts from voltage control to current control. The unit operates normally once the output current is brought back into its specified range.

Input Source Impedance

The power module should be connected to a low ac-impedance input source. Highly inductive source impedances can affect the stability of the power module.

In applications where power is supplied over long lines and output loading is high, it may be necessary to use a capacitor on the input to insure startup.

By using a good quality low Equivalent Series Resistance (ESR < 1.0[at 100 kHz) capacitor of a 8.2uF for the 5V input devices, a 3.3uF for the 12V input devices and a 1.5uF for the 24V and 48V devices, capacitor mounted close to the power module helps ensure stability of the unit.

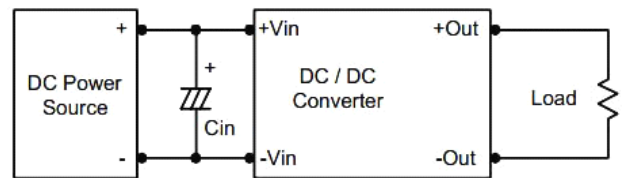

Output Ripple Reduction

A good quality low ESR capacitor placed as close as practicable across the load will give the best ripple and noise performance.

To reduce output ripple, it is recommended that 3.3uF capacitors are used on output.

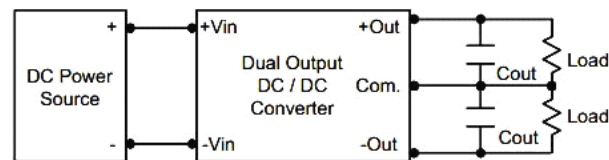
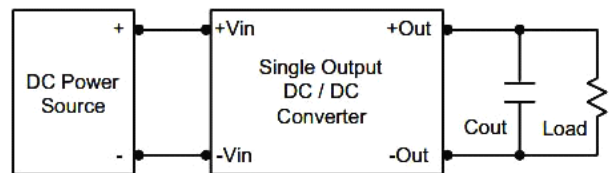

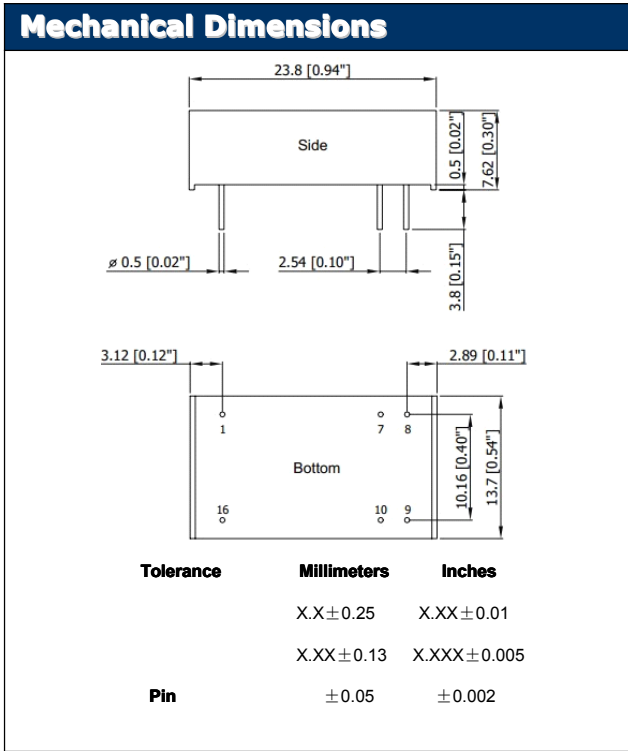

Physical Characteristics

Case Size :	23.8*13.7*7.62 mm 0.94*0.54*0.30 inches
Case Material:	Non-Conductive Black Plastic
Weight:	5.1g
Flammability:	UL94V-0

Pin Connections

Pin	Single Output	Dual Output
1	-Vin	-Vin
7	NC	NC
8	NC	Common
9	+Vout	+Vout
10	-Vout	-Vout
16	+Vin	+Vin

NC: No Connection

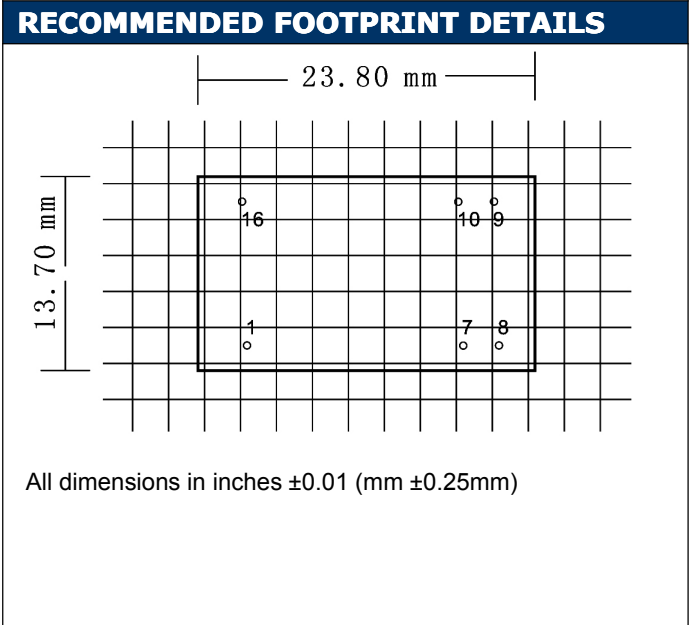

RoHS COMPLIANT INFORMATION

This series is compatible with RoHS soldering systems with a peak wave solder temperature of 300° C for 10 seconds.
 The pin termination finish on the SIP package type is Tin Plate, Hot Dipped over Matte Tin with Nickel Preplate. The DIP types are Matte Tin over Nickel Preplate. Both types in this series are backward compatible with Sn/Pb soldering systems.

REACH COMPLIANT INFORMATION

This series has proven that this product does not contain harmful chemicals, it also has harmful chemical substances through the registration, inspection and approval.