

PLEASE CHECK WWW.MOLEX.COM FOR LATEST PART INFORMATION

Part Number: [0008550111](#)
Status: **Active**
Overview: [kk](#)
Description: KK® Cat Ear Crimp Terminal 4809, 22-30 AWG, Bag Selective Gold (Au)

Documents:

[3D Model](#) [Product Specification PS-99020-0088 \(PDF\)](#)
[Drawing \(PDF\)](#) [RoHS Certificate of Compliance \(PDF\)](#)
[Product Specification PS-10-07 \(PDF\)](#)

General

Product Family Crimp Terminals
 Series [4809](#)
 Crimp Quality Equipment Yes
 Overview [kk](#)
 Product Name Cat Ear, KK®

Physical

Gender Female
 Material - Metal Brass
 Material - Plating Mating Gold
 Material - Plating Termination Gold
 Packaging Type Bag
 Plating min: Mating (µin) 15.2
 Plating min: Mating (µm) 0.38
 Plating min: Termination (µin) 15.2
 Plating min: Termination (µm) 0.38
 Termination Interface: Style Crimp or Compression
 Wire Insulation Diameter 1.57mm (.062") max.
 Wire Size AWG 22, 24, 26, 28, 30
 Wire Size mm² N/A

Material Info

Old Part Number 4809555L

Reference - Drawing Numbers

Product Specification PS-10-07, PS-99020-0088
 Sales Drawing SD-4809-*

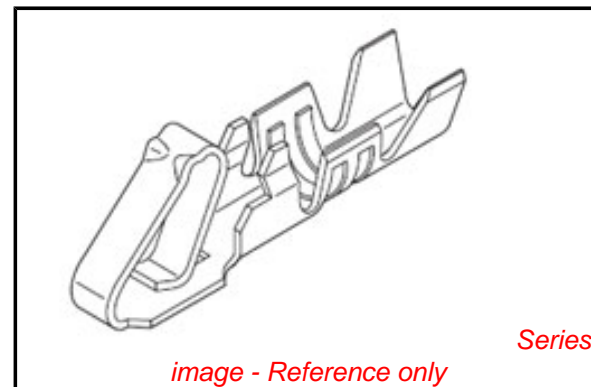

image - Reference only

EU RoHS

**ELV and RoHS
 Compliant**
**REACH SVHC
 Contains SVHC: No**
**Halogen-Free
 Status**

China RoHS



**Need more information on product
 environmental compliance?**

Email productcompliance@molex.com
 For a multiple part number RoHS Certificate of
 Compliance, [click here](#)

Please visit the [Contact Us](#) section for any
 non-product compliance questions.

Search Parts in this Series

[4809Series](#)

Application Tooling | [FAQ](#)

*Tooling specifications and manuals are
 found by selecting the products below.
 Crimp Height Specifications are then
 contained in the Application Tooling
 Specification document.*

Global

Description	Product #
Extraction Tool	0011030022
Insertion Tool	0638120000
Hand Crimp Tool	0638118200

NOTES*

1. MATERIAL: (0.2)/.008 THICK BRASS 70/30, FOR MATL. SPEC SEE SHEET 2.
2. SUITABLE FOR 22-30 GA WIRE, (1.57)/.062 MAX INSULATION.
3. CODE LETTER PRECEDING PART No DESIGNATES MANUFG. LOCATION, I=IRELAND.
4. TERMINAL MUST MEET BEND SPEC. SDES-219.
5. THIS PART CONFORMS TO PROD. SPEC.99020-0088

SECTION D-D
(4809-1T ONLY)

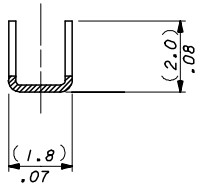

SECTION B-B

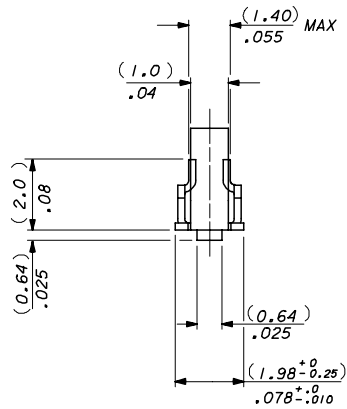

SECTION A-A

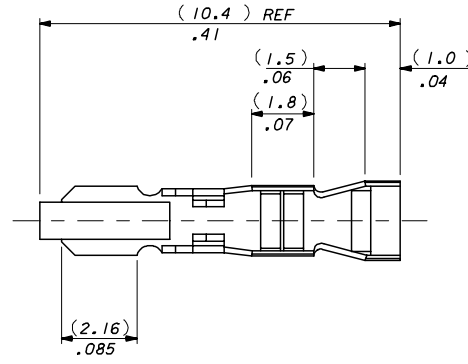
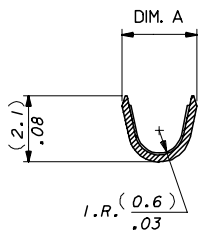

SELECTIVE PLATING AREA,
SEE CHART AND SDES-186

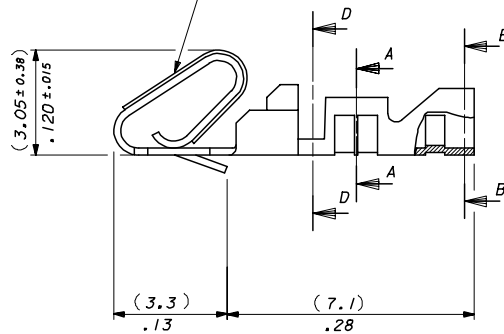

SECTION A-A

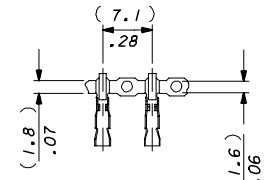
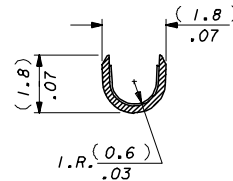

CARRIER STRIP DETAIL
SCALE 2:1

- 4809-(*)**
- BLANK : DIM. A = (2.45-1.75) / .096-.069
 - M: DIM A = (2.35-2.05) / .093-.081
 - BLANK-CHAIN FORM TOP FEEDING REEL
 - L-LOOSE FORM
 - BF-CHAIN FORM, BOTTOM FEEDING REEL

DIM CORRECTION EIC NO. E2007-0218 DRAWN: JDENNEHY 2006/09/15 CHK'D: DMOR IARTY 2006/09/15 APPR: JDENNEHY 2006/10/11	QUALITY SYMBOLS ▽=0 ▽=0	GENERAL TOLERANCES (UNLESS SPECIFIED)		DIMENSION STYLE MM/IN	SCALE 10:1	DESIGN UNITS METRIC	THIRD ANGLE PROJECTION
		4 PLACES ± --- ± --- 3 PLACES ± --- ± .010 2 PLACES ± 0.25 ± .014 1 PLACE ± 0.35 ± --- ANGULAR ± --- °	DRAWN BY MCC	DATE 1986/07/30	CHECKED BY DMOR IARTY	DATE 2004/10/18	TITLE ANTI-FISH HOOKING TERMINAL KK.(2.50)/.100
AL	DRAFT WHERE APPLICABLE MUST REMAIN WITHIN DIMENSIONS	SEE CHART		APPROVED BY JDENNEHY	DATE 2004/10/19	MOLEX INCORPORATED	
		MATERIAL NO. A2	DOCUMENT NO. SD-4809-*		SHEET NO. 1 OF 2		

FINISH NOTES*

- (P902) HOT TIN DIP 1.0- 2.5UM/(.000040 - .000100)
- (999) UNPLATED
- (109) ELECTRO TIN PLATE (7.6-10UM)/.000300-.000400 OVER (1.25-2.0UM)/.000050-.000080 COPPER.
- (505) GOLD PLATE (1.25-1.5UM)/.000050-.000060 OVER (1.25-2.0UM)/.000050-.000080 NICKEL.
- (506) GOLD PLATE (1.25-1.5UM)/.000050-.000060 OVER (2.5-3.25UM)/.000100-.000130 NICKEL.
- (507) GOLD PLATE (2.5-2.75UM)/.000100-.000110 OVER (1.25-2.0UM)/.000050-.000080 NICKEL.
- (509) GOLD PLATE (1.25-1.5UM)/.000050-.000060 OVER (0.76-2.0UM)/.000030-.000080 NICKEL.
- (550) GOLD PLATE (0.38-0.63UM)/.000015-.000025 OVER (0.76-1.5UM)/.000030-.000060 NICKEL IN CONTACT AREA WITH (0.12UM)/.000005 MIN. GOLD FLASH OVERALL.
- (555) SELECTIVE GOLD (0.38UM)/.000015 OVER (0.76UM)/.000030 IN CONTACT AREA ONLY.
- (558) GOLD PLATE (0.76-1.5UM)/.000030-.000060 OVER (1.25-2.0UM)/.000050-.000080 NICKEL IN CONTACT AREA WITH (0.12UM)/.000005 MIN. GOLD FLASH OVERALL.

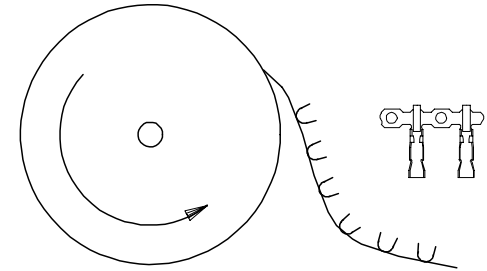

TERMINALS FEEDING FROM THE TOP OF THE REEL ARE STANDARD WOUND

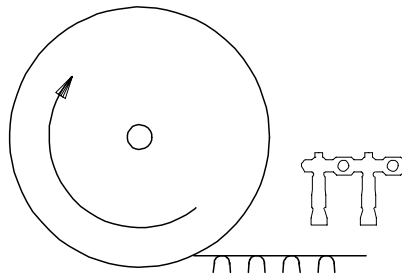

TERMINALS FEEDING FROM THE BOTTOM OF THE REEL ARE REVERSE WOUND SEE NOTE 5

I	08-50-0022	4809-(109)BF	CHAIN	(109)	(2.1)/.083 REF
I	40-01-0831	↑ -(999)BF	↑	(999)	(2.1)/.083 REF
	NT	-(505)BF		(505)	(2.1)/.083 REF
	NT	-(507)BF		(507)	(2.1)/.083 REF
I	08-55-0119	↓ -(555)BF	↓	(555)	(2.1)/.083 REF
I	08-56-0155	↓ -(550)BF	↓	(550)	(2.1)/.083 REF
I	08-50-0021	4809-(P902)BF	CHAIN	(P902)	(2.1)/.083 REF
	PART No	ENG No	FORM	FINISH	DIM . A

BOTTOM FEEDING REELS ONLY

	NT	4809-(506)	CHAIN	(506)	ES-99001-0014	(2.1)/.083 REF
	NT	↑ -(506)JL	LOOSE	(506)		(2.1)/.083 REF
I	08-56-0158	↓ -(558)	CHAIN	(558)		(2.1)/.083 REF
	NT	-(558)JL	LOOSE	(558)		(2.1)/.083 REF
	NT	-(509)	CHAIN	(509)		(2.1)/.083 REF
	NT	-(509)JL	LOOSE	(509)		(2.1)/.083 REF
	NT	-(109)	CHAIN	(109)		(2.1)/.083 REF
	NT	-(109)JL	LOOSE	(109)		(2.1)/.083 REF
I	40-01-0829	↓ -(999)	CHAIN	(999)		(2.1)/.083 REF
I	40-01-0830	↓ -(999)JL	LOOSE	(999)		(2.1)/.083 REF
	NT	-(505)	CHAIN	(505)		(2.1)/.083 REF
	NT	-(505)JL	LOOSE	(505)		(2.1)/.083 REF
	NT	-(507)	CHAIN	(507)		(2.1)/.083 REF
	NT	-(507)JL	LOOSE	(507)		(2.1)/.083 REF
I	08-55-0110	↓ -(555)	CHAIN	(555)		(2.1)/.083 REF
I	08-55-0111	↓ -(555)JL	LOOSE	(555)		(2.1)/.083 REF
	08-56-0120	↓ -(550)	CHAIN	(550)	ES-99001-0014	(2.1)/.083 REF
	08-56-0115	↓ -(550)JL	LOOSE	(550)		(2.1)/.083 REF
I	08-50-0135	↓ -(P902)	CHAIN	(P914)	ES-99001-0015	(2.1)/.083 REF
I	08-50-0136	4809-(P902)JL	LOOSE	(P914)	ES-99001-0015	(2.1)/.083 REF
	PART No	ENG No	FORM	FINISH	MATL. SPEC.	DIM . A

TOP FEEDING REELS ONLY

ADDED PART OPTION ECC No: E2005-0286 DRWNG: MCKWEN 2004/11/03 CHKD: DMOR IART 2004/11/03 APPR: JDEWNEY 2004/11/04 REV	DESCRIPTION QUALITY SYMBOLS ▽=0 ▽=0	GENERAL TOLERANCES (UNLESS SPECIFIED)		DIMENSION STYLE		SCALE	DESIGN UNITS	THIRD ANGLE PROJECTION			
				MM/IN		NTS	METRIC				
				4 PLACES ± --- ± ---		DRAWN BY		DATE			
				3 PLACES ± --- ± .010		MCC		1986/07/30			
		2 PLACES ± 0.25 ± .014		CHECKED BY		DATE					
		1 PLACE ± 0.35 ± ---		DMOR IART		2004/10/18					
		ANGULAR ± --- °		APPROVED BY		DATE					
				JDEWNEY		2004/10/19					
		DRAFT WHERE APPLICABLE MUST REMAIN WITHIN DIMENSIONS		MATERIAL NO.		DOCUMENT NO.		SHEET NO.			
				SEE CHART		SD-4809-*		2 OF 2			
				THIS DRAWING CONTAINS INFORMATION THAT IS PROPRIETARY TO MOLEX INCORPORATED AND SHOULD NOT BE USED WITHOUT WRITTEN PERMISSION							