

Weight: 0.31g Unit: mm

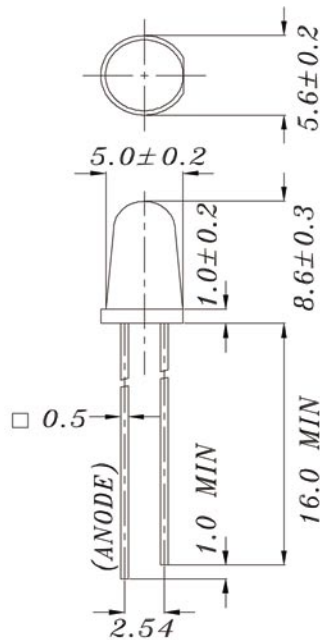

AND180HRP AlGaInP High Brightness Red Light Emission T-1 3/4 Package (5mm)

Features

- Peak wavelength ($\lambda_p = 644$ nm) high bright emission
- All plastic mold type, clear colorless lens
- Low drive current: 1 to 20 mA DC
- Excellent On-Off contrast ratio
- Fast response time, capable of pulse operation
- High power luminous intensity
- Suitable for outdoor Message Signboards
- RoHS compliant

Maximum Ratings (Ta - 25 °C)

Characteristic	Symbol	Rating	Unit
Forward Current	I_F	50	mA
Reverse Voltage	V_R	4	V
Power Dissipation	P_D	125	mW
Operating Temperature Range	T_{OPR}	-40 to 85	°C
Storage Temperature Range	T_{STG}	-40 to 100	°C

Electro-Optical Characteristics (Ta = 25°C)

Item	Symbol	Test Condition	Minimum	Typical	Maximum	Unit
Forward Voltage	V_F	$I_F = 20$ mA	-	1.9	2.5	V
Reverse Current	I_R	$V_R = 4$ V	-	-	50	μ A
Luminous Intensity	I_v	$I_F = 20$ mA	3,200	6,000	-	mcd
Peak Emission Wavelength	λ_p	$I_F = 20$ mA	-	644	-	nm
Spectral Line Half Width	$\Delta\lambda$	$I_F = 20$ mA	-	18	-	nm
Dominant Wavelength	λ_d	$I_F = 20$ mA	-	630	-	nm
Full Viewing Angle	θ	$I_v = 1/2$ Peak	-	8	-	degree

Precaution

Please be careful of the following:

1. Dip soldering temperature: 260°C max
Soldering time: 5 sec. max
Soldering portion of lead: up to 1.6 mm from the body of the device
2. The lead can be formed up to 5 mm from the body of the device without forming stress.
Soldering should be performed after the lead forming.

Product specifications contained herein may be changed without prior notice.

□

