

DESCRIPTION

The CS5201 series of positive adjustable and fixed regulators are designed to provide 1A with higher efficiency than currently available devices. All internal circuitry is designed to operate down to 700 mV input to output differential and the dropout voltage is fully specified as a function of load current. Dropout voltage of the device is 100 mV at light loads and rising to 700 mV at maximum output current. A second low current input is required to achieve this dropout. The CS5201 can also be used as single supply device (3 pin version).

FEATURES

- Adjustable or Fixed Output.
- Output Current of 1A.
- Low Dropout, 700 mV at 1A Output Current.
- 0.04% Line Regulation.
- 0.1% Load Regulation.
- 100% Thermal Limit Burn-In.
- Fast Transient Response.
- Remote Sense.

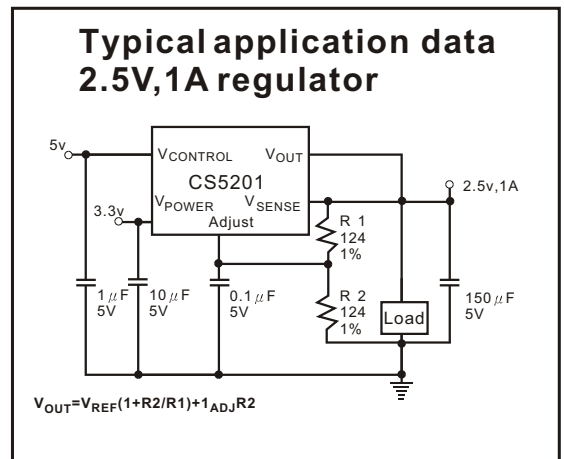
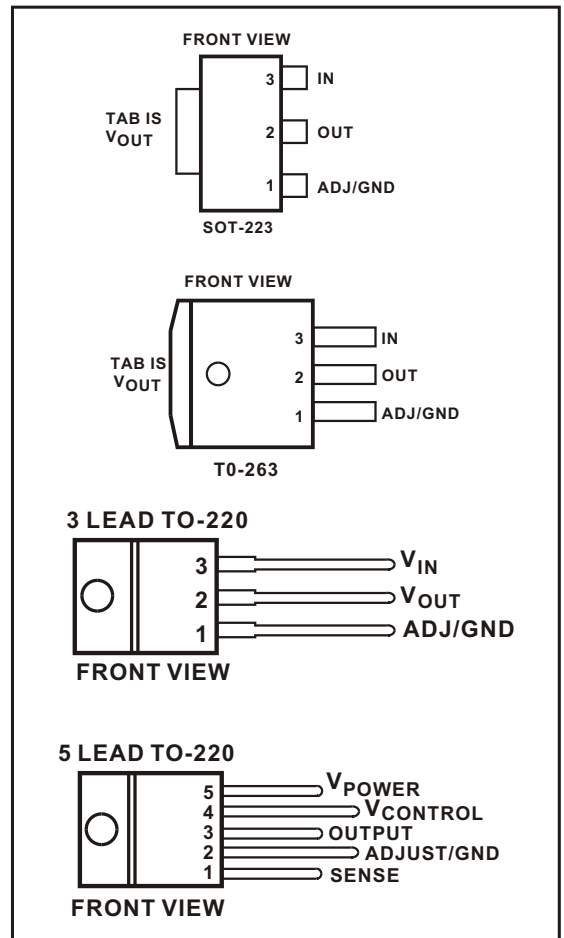

Absolute Maximum Ratings

Symbol	Parameter	Maximum	Units
P _D	Power Dissipation	Internally Limited	W
V _{IN}	Input Voltage V _{power} V _{control}	7 13	V
T _J	Operating Junction Temperature Range Control Section Power Transistor	0 to 125 0 to 150	°C
T _{STG}	Storage Temperature	-65 to 150	°C
T _{LEAD}	Lead Temperature(Soldering, 10 sec)	300	°C

Electrical Characteristics(Note 1)

Electrical Characteristics at $I_{LOAD}=0$ mA and $T_J=+25^{\circ}C$ unless otherwise specified.

Parameter	Device	Test Conditions		Min	Typ	Max	Units
Reference Voltage	CS5201	$V_{CONTROL}=2.75V, V_{POWER}=2V, I_{LOAD}=10mA$		1.238	1.250	1.262	V
		$V_{CONTROL}=2.7V$ to 12V, $V_{POWER}=3.3V$ to 5.5V, $I_{LOAD}=10mA$ to 1A	*	1.230	1.250	1.270	
Output Voltage	CS5201 -1.5	$V_{CONTROL}=4V, V_{POWER}=2V$		1.485	1.500	1.515	V
		$V_{CONTROL}=3V, V_{POWER}=3.3V, I_{LOAD}=0mA$ to 1A	*	1.475	1.500	1.525	
	CS5201 -2.5	$V_{CONTROL}=5V, V_{POWER}=3.3V$		2.475	2.500	2.525	V
		$V_{CONTROL}=4V, V_{POWER}=3.3V, I_{LOAD}=0mA$ to 1A	*	2.460	2.500	2.540	
	CS5201 -2.85	$V_{CONTROL}=5.35V, V_{POWER}=3.35V$		2.821	2.850	2.879	V
		$V_{CONTROL}=4.4V, V_{POWER}=3.7V, I_{LOAD}=0mA$ to 1A	*	2.805	2.850	2.895	
	CS5201 -3.0	$V_{CONTROL}=5.5V, V_{POWER}=3.5V$		2.970	3.000	3.030	V
		$V_{CONTROL}=4.5V, V_{POWER}=3.8V, I_{LOAD}=0mA$ to 1A	*	2.950	3.000	3.050	
CS5201 -3.3	$V_{CONTROL}=5.8V, V_{POWER}=3.8V$		3.267	3.300	3.333	V	
	$V_{CONTROL}=4.8V, V_{POWER}=4.1V, I_{LOAD}=0mA$ to 1A	*	3.247	3.300	3.353		
CS5201 -3.5	$V_{CONTROL}=6V, V_{POWER}=4V$		3.465	3.500	3.535	V	
	$V_{CONTROL}=5V, V_{POWER}=4.3V, I_{LOAD}=0mA$ to 1A	*	3.445	3.500	3.555		
CS5201 -5.0	$V_{CONTROL}=7.5V, V_{POWER}=5.5V$		4.950	5.000	5.050	V	
	$V_{CONTROL}=6.5V, V_{POWER}=5.8V, I_{LOAD}=0mA$ to 1A	*	4.920	5.000	5.080		
Line Regulation	All	$I_{LOAD}=10mA, (1.5V+V_{OUT}) \leq V_{CONTROL} \leq 12V,$ $0.8V \leq (V_{POWER}-V_{OUT}) \leq 5.5V$	*		0.04	0.20	%
Load Regulation	All	$V_{CONTROL}=V_{OUT}+2.5V, V_{POWER}=V_{OUT}+0.8V,$ $I_{LOAD}=10mA$ to 1A	*		0.08	0.40	%
Minimum Load Current (Note 2)	CS5201	$V_{CONTROL}=5V, V_{POWER}=3.3V, V_{ADJ}=0V$	*		1.7	5	mA
Control Pin Current (Note 3)	All	$V_{CONTROL}=V_{OUT}+2.5V, V_{POWER}=V_{OUT}+0.8V,$ $I_{LOAD}=10mA$ to 1A	*			20	mA
Ground Pin Current	CS5201-1.5/ -2.5/-2.85 -3.0/-3.3/-3.5 -5.0	$V_{CONTROL}=V_{OUT}+2.5V, V_{POWER}=V_{OUT}+0.8V,$ $I_{LOAD}=10mA$ to 1A	*		5	10	μA
Adjust Pin Current	CS5201	$V_{CONTROL}=2.75V, V_{POWER}=2.05V,$ $I_{LOAD}=10mA$	*		50	120	mA
Current Limit	All	$(V_{IN}-V_{OUT})=3V$	*	1000	1500		mA
Ripple Rejection	All	$V_{CONTROL}=V_{POWER}=V_{OUT}+2.5V, V_{RIPPLE}=1V_{P-P},$ $I_{LOAD}=500mA$	*	60	75		dB
Thermal Regulation	CS5201	$T_A=25^{\circ}C, 30ms$ pulse			0.003		%/W
Dropout Voltage Note 4							
Control Input ($V_{CONTROL} - V_{OUT}$)	All	$V_{POWER}=V_{OUT}+0.8V, I_{LOAD}=10mA$ $V_{POWER}=V_{OUT}+0.8V, I_{LOAD}=1A$	*		1.00 1.15	1.15 1.30	V
Power Input ($V_{POWER} - V_{OUT}$)	All	$V_{CONTROL}=V_{OUT}+2.5V, I_{LOAD}=1A$	*		0.55	0.70	V

The * denotes the specifications which apply over the full temperature range.

Note 1: Unless otherwise specified $V_{out} = V_{sense}$. For CS5201(adj) $V_{adj} = 0V$

Note 2: For the adjustable device the minimum load current is the minimum current required to maintain regulation. Normally the current in the resistor divider used to set the output voltage is selected to meet the minimum load current requirement.

Note 3: The control pin current is the drive current required for the output transistor. This current will track output current with a ratio of about 1:100.

Note 4: The dropout voltage for the CS5201 is caused by either minimum control voltage or minimum power voltage. The specifications represent the minimum input/output voltage required to maintain 1% regulation.

Pin Functions (5-Lead)

Sense (Pin 1): This pin is the positive side of the reference voltage. With this pin it is possible to Kelvin Sense the output voltage at the load.

Adjust (Pin 2): This pin is the negative side of the reference voltage. Adding a small bypass capacitor from the Adjust pin to ground improves the transient response. For fixed voltage devices the Adjust pin is also brought out to allow the user to add a bypass capacitor.

GND (Pin 2): For fixed voltage device this is the bottom of the resistor divider that sets the output voltage.

VPOWER (Pin 5): This pin is the collector of the power transistor. The output load current is supplied through this pin. The voltage at this pin must be 0.7V greater than the output voltage for the device to regulate.

VCONTROL (Pin 4): This pin is the supply pin for the control circuitry. The current flow into this pin will be about 1% of the output current. The voltage at this pin must be 1.3V greater than the output voltage for the device to regulate.

Output (Pin 3): This is the power output of the device.

Block Diagram

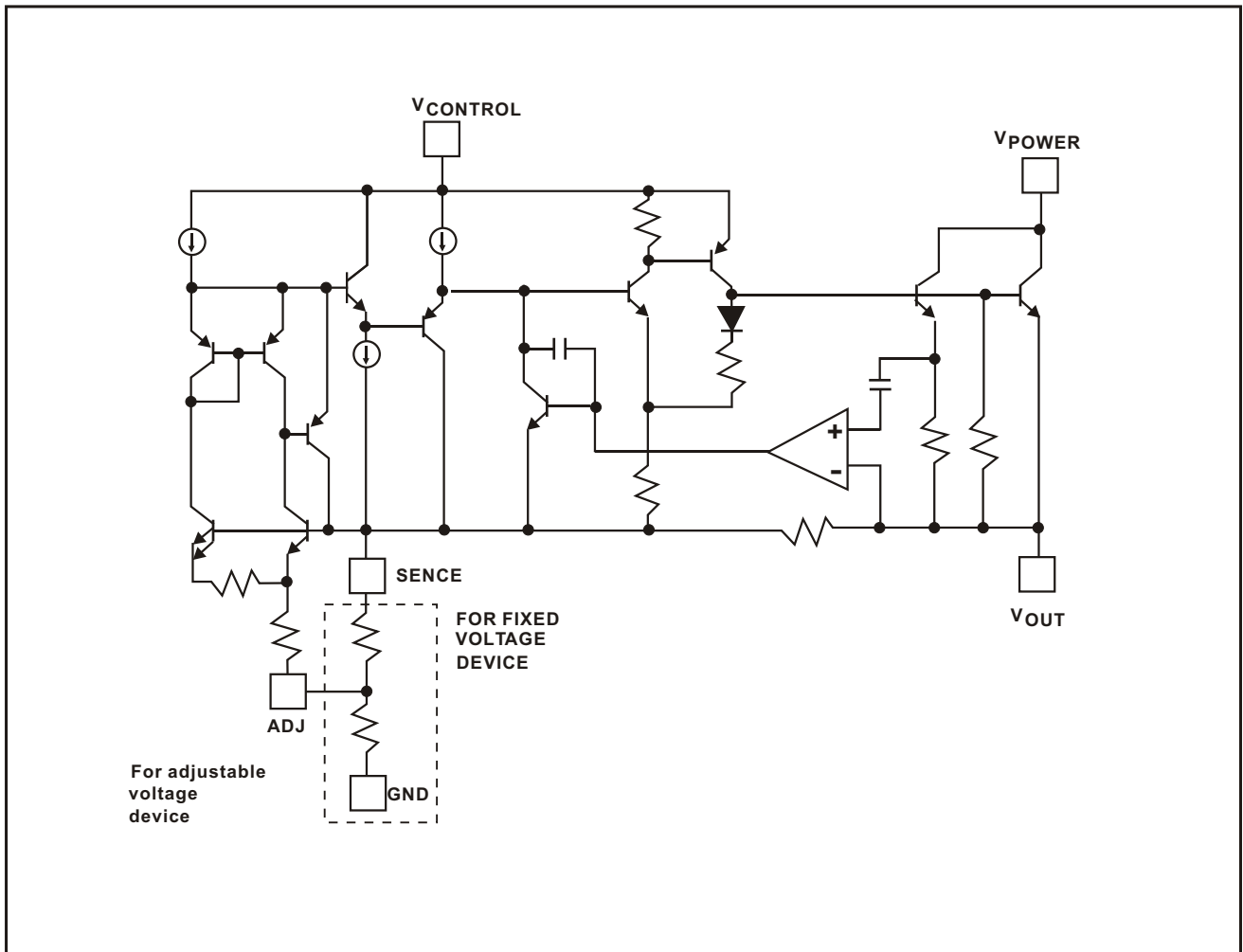

Application Information

The CS5201 is designed to make use of multiple power supplies, to reduce the dropout voltage. One of the advantages of the two supply approach is maximizing the efficiency.

The second supply is at least 1V greater than output voltage and is providing the power for the control circuitry and supplies the drive current to the NPN output transistor. This allows the NPN output transistor to be driven into saturation. For the control voltage the current requirement is small equal to about 1% of the output current. This drive current becomes part of the output current. The maximum voltage on the Control pin is 12V. The maximum voltage at the Power pin is 7V. By tying the control and power inputs together the CS5201 can also be operated as a single supply device. In single supply operation the dropout will be determined by the minimum control voltage.

Both the fixed and adjustable versions have remote sense pins, permitting very accurate regulation of output voltage. As a result, over an output current range of 100mA to 1A, the typical load regulation is less than 1mV. For the fixed voltages the adjust pin is brought out allowing the user to improve transient response by bypassing the internal resistor divider. Optimum transient response is provided using a capacitor in the range of 0.1 μ F to 1 μ F for bypassing the Adjust pin.

In addition to the enhancements mentioned, the reference accuracy has been improved a factor of two with a guaranteed initial tolerance of $\pm 1\%$ at 25°C and 1.6% accuracy over the full temperature and load current range

Typical applications for the CS5201 include 3.3V to 2.5V conversion with a 5V control supply, 5V to 4.2V conversion with a 12V control supply or 5V to 3.6V conversion with a 12V control supply. The device is fully protected against overcurrent and overtemperature conditions.

Grounding and Output Sensing

The CS5201 allows true Kelvin sensing for both the high and low side of the load. As a result the voltage regulation at the load can be easily optimized. Voltage drops due to parasitic resistances between the regulator and the load can be placed inside the regulation loop. The advantages of remote sensing are illustrated in figures 1 through 3. Figure 1 shows the device connected as a conventional 3 terminal regulator with the Sense lead connected directly to the connections between the device and the load. Trace A of figure 3 illustrates the effect of R_p .

Figure 2 shows the device connected to take advantage of the remote sense feature. The Sense pin and the top of the resistor divider are connected to the top of the load; the bottom of the resistor divider is connected to the bottom of the load. The effect on output regulation can be seen in trace B of figure 3.

It is important to note that the voltage drops due to R_p , are not eliminated; they will add to the dropout voltage of the regulator regardless. The CS5201 can control the voltage at the load as long as the input-output voltage is greater than the total of the dropout voltage of the device plus the voltage drop across R_p .

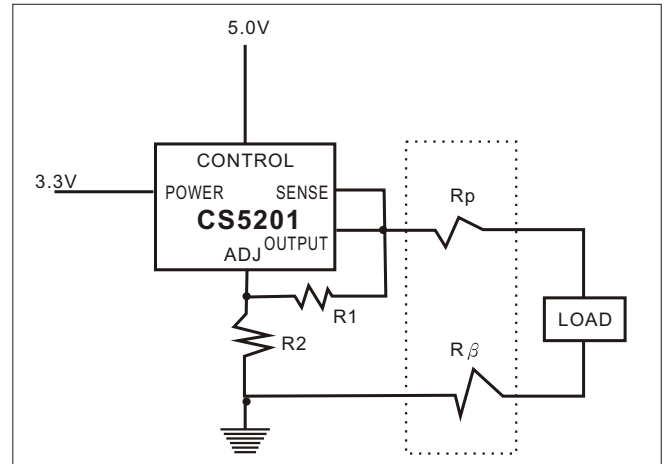

Figure 1. Conventional Load Sensing

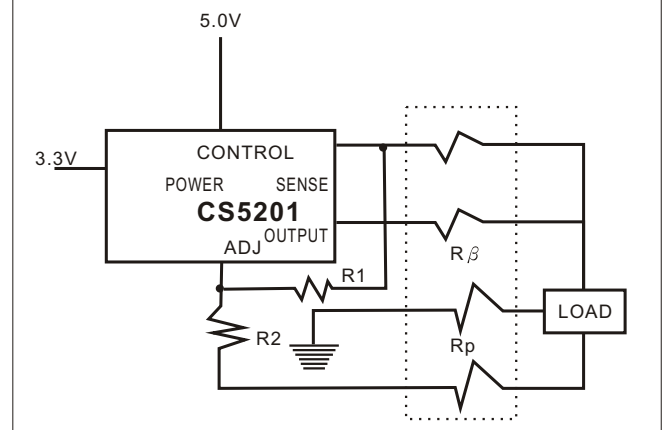

Figure 2. Remote Load Sensing

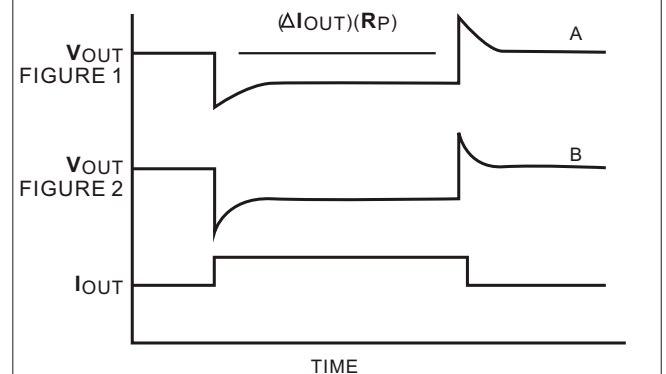

Figure 3. Remote Sensing Improves Load Regulation

Stability

The circuit design used in the CS5201 series requires the use of an output capacitor as part of the device frequency compensation. The addition of 150 μ F aluminum electrolytic or a 22 μ F solid tantalum on the output will ensure stability for all operating conditions.

Output Voltage

The CS5201 (adjustable version) develops a 1.25V reference voltage between the Sense pin and the Adjust pin (Figure 4). Placing a resistor between these two terminals causes a constant current to flow through R1 and down through R2 to set the output voltage. In general R1 is chosen so that this current is the specified minimum load current of 5 mA. The current out of the Adjust pin is small, typically 50 μ A and it adds to the current from R1. For best regulation the top of the resistor divider should be connected directly to the Sense pin.

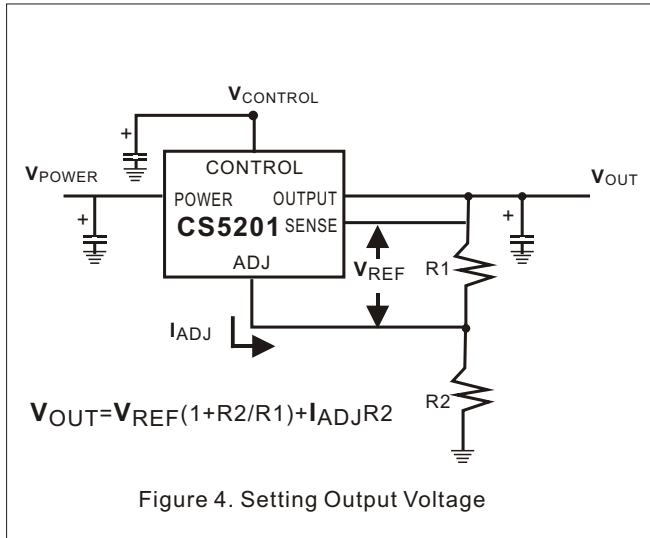

Protection Diodes

In normal operation CS5201 family does not need any protection diodes between the adjustment pin and the output and from the output to the input to prevent die overstress. Internal resistors are limiting the internal current paths on the ADJ pin. Therefore even with bypass capacitors on the adjust pin no protection diode is needed to ensure device safety under short-circuit conditions. The Adjust pin can be driven on a transient basis ± 7 V with respect to the output without any device degradation.

A protection diode between the Output pin and V_{POWER} pin is not usually needed. Microsecond surge currents of 50A to 100A can be handled by the internal diode between the Output pin and V_{POWER} pin of the device.

In normal operations it is difficult to get those values of surge currents even with the use of large output capacitances. Only with high value output capacitors, such as 1000 μ F to 5000 μ F and the V_{POWER} pin is instantaneously shorted to ground, damage can occur. A diode from output to input is recommended (Figure 5).

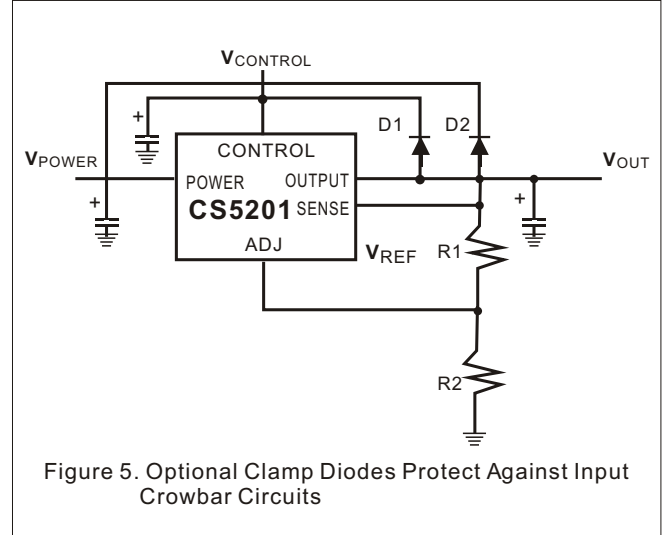

If CS5201 is connected as a single supply device with the control and power input pins shorted together the internal diode between the output and the power input pin will protect the control input pin.

Thermal Considerations

The CS5201 series have internal power and thermal limiting circuitry designed to protect the device under overload conditions. However maximum junction temperature ratings should not be exceeded under continuous normal load conditions. Careful consideration must be given to all sources of thermal resistance from junction to ambient, including junction-to-case, case-to-heat sink interface and heat sink resistance itself.

Junction temperature of the Control section can run up to 125°C. Junction temperature of the Power section can run up to 150°C.

ORDER INFORMATION

Device	Output Voltage	Package
CS5201ST	Adj	SOT-223
CS5201T	Adj	TO-220
CS5201T1	Adj	TO-220-5
CS5201DP	Adj	TO-263
CS5201ST-1.5	1.5V	SOT-223
CS5201T-1.5	1.5V	TO-220
CS5201T1-1.5	1.5V	TO-220-5
CS5201DP-1.5	1.5V	TO-263
CS5201ST-2.5	2.5V	SOT-223
CS5201T-2.5	2.5V	TO-220
CS5201T1-2.5	2.5V	TO-220-5
CS5201DP-2.5	2.5V	TO-263
CS5201ST-2.85	2.85V	SOT-223
CS5201T-2.85	2.85V	TO-220
CS5201T1-2.85	2.85V	TO-220-5
CS5201DP-2.85	2.85V	TO-263
CS5201ST-3	3V	SOT-223
CS5201T-3	3V	TO-220
CS5201T1-3	3V	TO-220-5
CS5201DP-3	3V	TO-263
CS5201ST-3.3	3.3V	SOT-223
CS5201T-3.3	3.3V	TO-220
CS5201T1-3.3	3.3V	TO-220-5
CS5201DP-3.3	3.3V	TO-263
CS5201ST-3.5	3.5V	SOT-223
CS5201T-3.5	3.5V	TO-220
CS5201T1-3.5	3.5V	TO-220-5
CS5201DP-3.5	3.5V	TO-263
CS5201ST-5	5V	SOT-223
CS5201T-5	5V	TO-220
CS5201T1-5	5V	TO-220-5
CS5201DP-5	5V	TO-263