

42-DL214

Version : A.03
Issue Date : 2003/09/30
File Name :
42-DL214-A.03(pre).doc
Total Pages : 6

Optical Fiber Transmitting IC

Preiminary



新竹市科學園區展業一路9號4樓之3
SILICON TOUCH TECHNOLOGY INC.
9-4F-3, Prosperity Road I, Science Based Industrial Park,
Hsin-Chu, Taiwan 300, R.O.C.
Tel : 886-3-5645656 Fax : 886-3-5645626

42-DL214

OPTICAL FIBER TRANSMITTING IC

GENERAL DESCRIPTION

42-DL214 is a driver IC designed for the application of high-speed optical fiber transmission. It integrates the LED driver with constant current output to reduce the complexity and the cost of the transmission module. 42-DL214 can transmit with the speed up to 25Mb/s. 42-DL214 are fabricated by using CMOS technology with low power consumption purpose.

FEATURES

1. TTL interface compatible
2. High speed (up to 25Mb/s)
3. Uniform output waveform
4. Constant current output
5. Low power consumption
6. Wide range for Supply Voltage (2.2V-3.6V)

BLOCK DIAGRAM And APPLICATION CIRCUIT

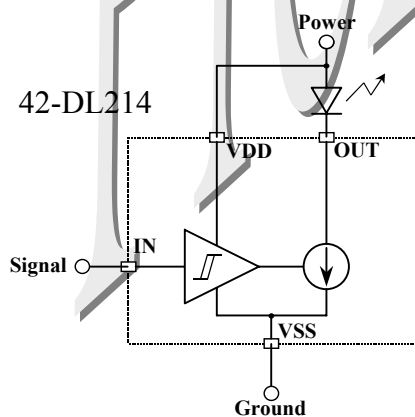



ABSOLUTE MAXIMUM RATINGS

Item	Symbol	Rating	Unit
Supply Voltage	V_{DD}	-0.5 to +6.5	V
Input Voltage	V_{IN}	-0.5 to $V_{DD} + 0.5$	V
Operating Temperature	T_{opr}	-40 to +85	°C
Storage Temperature	T_{stg}	-55 to +100	°C
Electrostatic Damage	ESD	HBM class 3	
Output Voltage	V_{OUT}	-0.5 to $V_{DD} + 0.5$	V

RECOMMENDED OPERATING CONDITIONS

ITEM	SYMBOL	MIN.	TYP.	MAX.	UNIT
Supply Voltage	V_{DD}	2.2	-	3.6	V
High Level Input Voltage	V_{IH}	2.0	-	V_{DD}	V
Low Level Input Voltage	V_{IL}	0	-	0.8	V

ELECTRICAL CHARACTERISTICS ($V_{DD}=2.4V$, $T_A=25^\circ C$, if not mentioned)

ITEM	SYMBOL	CONDITIONS	MIN.	TYP.	MAX.	UNIT
High Level Input Voltage	V_{IH}	-	2.0	-	V_{DD}	V
Low Level Input Voltage	V_{IL}	-	0	-	0.8	V
Input Leakage Current	I_{IN}	$V_{IN}=V_{DD}$ or V_{SS}	-	-	1	uA
Quiescent Supply Current	I_{DDQ}	$V_{IN}=V_{DD}$	-	0.5	1.4	mA
Output Sinking Current	I_{OUT_ON}	$V_{IN}=V_{DD}$ $C_{LED}=15pF$, $V_{FLED}=1.6V$	3.52	4.4	5.28	mA
Output Leakage Current	I_{OUT_OFF}	$V_{OUT}=V_{DD}$, $V_{IN}=V_{SS}$	-	-	5	uA
Propagation Delay	T_{PLH} , T_{PHL}	$C_{LED}=15pF$, $V_{FLED}=1.6V$	-	-	100	ns
Rise Time, Fall Time of I_{OUT}	T_r , T_f	$C_{LED}=15pF$, $V_{FLED}=1.6V$	-	14	-	ns
Pulse Width Distortion	Δtw	$C_{LED}=15pF$, $V_{FLED}=1.6V$	- 25	0	25	ns
Jitter of Output Current	Δtj	$C_{LED}=15pF$, $V_{FLED}=1.6V$		1	25	ns
Data Rate	F_{DATA}	NRZ Code, $C_{LED}=15pF$, $V_{FLED}=1.6V$	-	-	25	Mb/s

PAD DESCRIPTIONS

PAD NO.	PAD NAME	DESCRIPTIONS
1	IN	Input Pad(Active High)
2	VDD	Supply Voltage
3	OUT	Output Pad Sinking Current(Active Low)
4	VSS	Ground

DIE CONFIGURATION

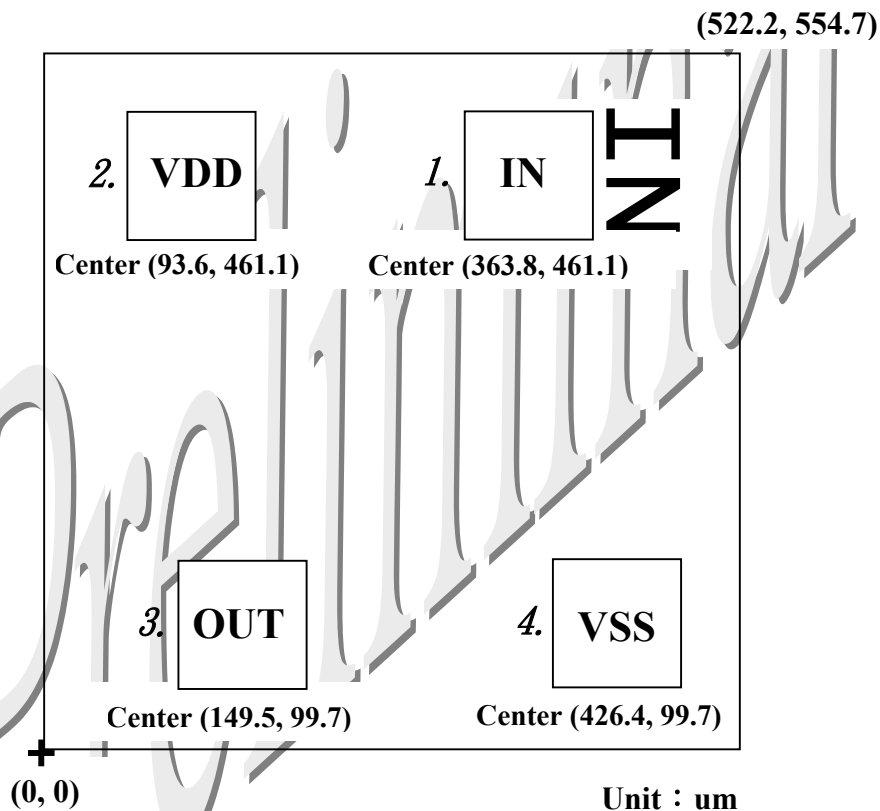

Die Size: 522.2um * 554.7um
Die Thickness: 12mil(=300um)
Pad Size: 100um * 100um

* **Note:** SiTI reserves the right to improve the device geometry and manufacturing processes without prior notice. Though these improvements may result in slight geometry changes, they will not affect die electrical characteristics and pad layouts.



REQUIREMENTS FOR WAFER DELIVERY

- Material : Silicon with P-Substrate
- Diameter : 6 inches(\approx 15cm)
- Thickness : 12 mils(\approx 300um)
- Malfunctioned die : Marked with red ink or equivalent marking

HANDLING RECOMMENDATION FOR STATIC ELECTRICITY PROTECTION

- (1) Avoid any circumstance that produce static electricity, e.g. rubbing against plastic, during moving, storing and processing 42-DL214.
- (2) Process 42-DL214 in a clean room with proper temperature and humidity.
- (3) Ground all working machines and workers wear anti-electrostatic ring to ground during processing.
- (4) Avoid contact 42-DL214 with bare hands. If unavioded, wear anti-electrostatic ring and use anti-electrostatic tool to pick it up.

GUARANTED TEMPERATURE AND RETENTION CYCLE

- (1) The device/wafer 42-DL214 should be stored in the nitrogenous chest. The conditions suggested are as follows:
 - Temperature = $23 \pm 3^{\circ}\text{C}$
 - Relative Humidity = $50 \pm 10\%$
 - Minimum nitrogen inflow = 3 liters/minute
- (2) If the device/wafer, 42-DL214 is incidentally exposed to the air, use it for manufacturing as soon as possible.
- (3) Under the storage environment specified in item (1), six-month safe storage period is guaranteed.



The products listed herein are designed for ordinary electronic applications, such as electrical appliances, audio-visual equipment, communications devices and so on. Hence, it is advisable that the devices should not be used in medical instruments, surgical implants, aerospace machinery, nuclear power control systems, disaster/crime-prevention equipment and the like. Misusing those products may directly or indirectly endanger human life, or cause injury and property loss.

Silicon Touch Technology, Inc. will not take any responsibilities regarding the misuse of the products mentioned above. Anyone who purchases any products described herein with the above-mentioned intention or with such misused applications should accept full responsibility and indemnify. Silicon Touch Technology, Inc. and its distributors and all their officers and employees shall defend jointly and severally against any and all claims and litigation and all damages, cost and expenses associated with such intention and manipulation.

preliminary