

See MIL-STD-1560 for
Insert Arrangement

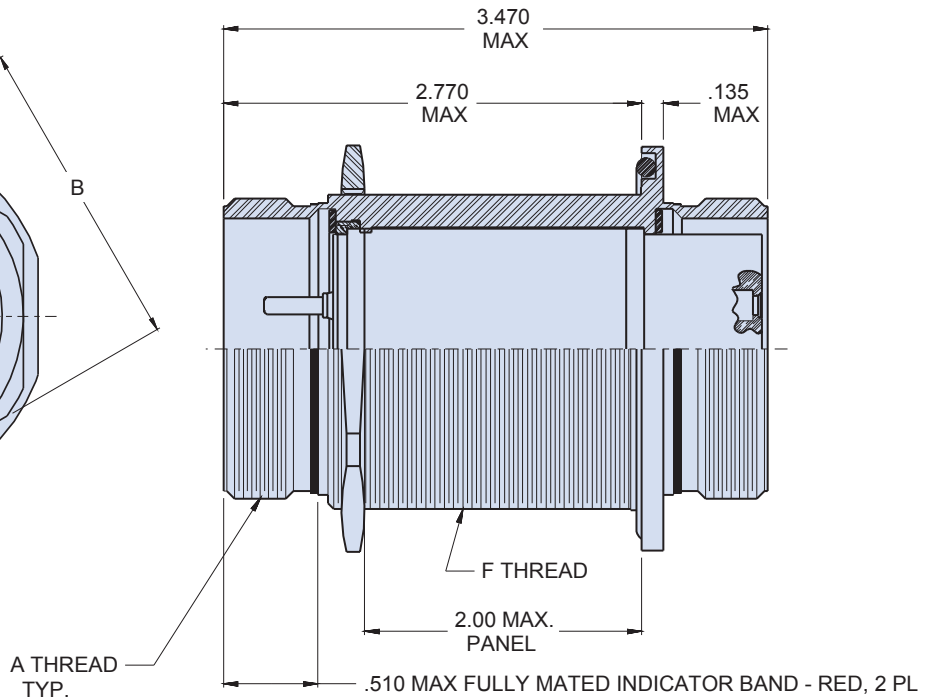

947-112
MIL-DTL-38999 Series III Type
Jam Nut Bulkhead Feed-Thru

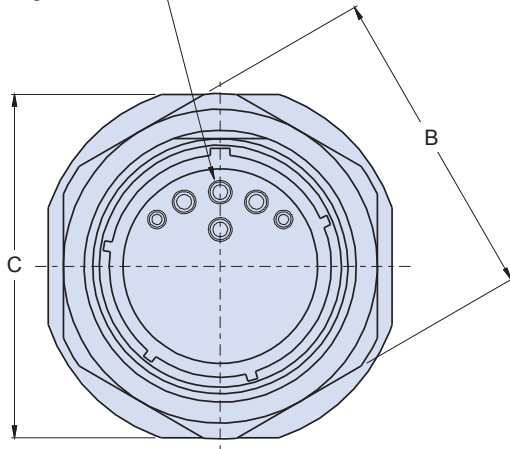
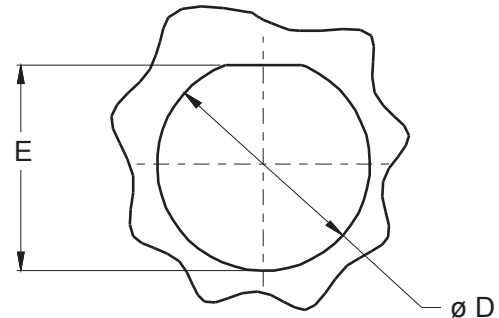

TABLE I: CONNECTOR DIMENSIONS

SHELL SIZE	A Thread 0.1P-0.3L-TS-2	B Dimension	C Dimension Max	D Diameter	E Dimension	F Thread x1-6g-0.100R
09	.6250	.875 (22.2)	1.08 (27.4)	6.98 (17.7)	.670 (17.0)	M17
11	.7500	1.000 (25.4)	1.27 (32.3)	.822 (20.9)	.771 (19.6)	M20
13	.8750	1.250 (31.8)	1.39 (35.3)	1.010 (27.6)	.995 (25.3)	M25
15	1.0000	1.375 (34.9)	1.52 (36.9)	1.135 (28.8)	1.085 (27.6)	M28
17	1.1875	1.500 (38.1)	1.64 (41.7)	1.260 (32.0)	1.210 (30.7)	M32
19	1.2500	1.625 (41.3)	1.83 (46.5)	1.385 (35.2)	1.335 (33.9)	M35
21	1.3750	1.750 (44.5)	1.95 (49.5)	1.510 (38.4)	1.460 (37.1)	M38
23	1.5000	1.875 (47.6)	2.08 (52.8)	1.635 (41.5)	1.585 (40.3)	M41
25	1.6250	2.000 (50.8)	2.20 (55.9)	1.760 (44.7)	1.710 (43.4)	M44

TABLE II: MATERIALS AND FINISH

SYM	FINISH
B	Cadmium Plate / Olive Drab
J	Gold Iridite over Cadmium Plate over Nickel
M	Electroless Nickel
N	Cadmium Plate / Olive Drab over Nickel
NF	Cadmium / Olive Drab over Electroless Nickel Nickel (500 Hour Salt Spray)
T	Cadmium Plate / Bright Dip Over Nickel



RECOMMENED PANEL CUT-OUT

APPLICATION NOTES

1. Assembly identified with manufacturers name and part number
2. Electrical safety limits must be established by user, peak voltage, switching surge, transient, etc. should be used to determine the safety applications.
3. Material/ Finishes:
Shells, Jam Nut - AL Alloy
Insulators- High Grade Rigid Dielectric/ N.A
Seals- Fluorosilicone/ N.A.