

Sep.1.2021 Copyright 2021 HIROSE ELECTRIC CO., LTD. All Rights Reserved.
In case of consideration for using Automotive equipment / device which demand high-reliability, kindly contact our sales window correspondents.

| COUNT | DESCRIPTION OF REVISIONS | BY | CHKD | DATE | COUNT | DESCRIPTION OF REVISIONS | BY | CHKD | DATE |
|-------|--------------------------|----|------|------|-------|--------------------------|----|------|------|
| △ | | | | .. | △ | | | | .. |
| △ | | | | .. | △ | | | | .. |
| △ | | | | .. | △ | | | | .. |

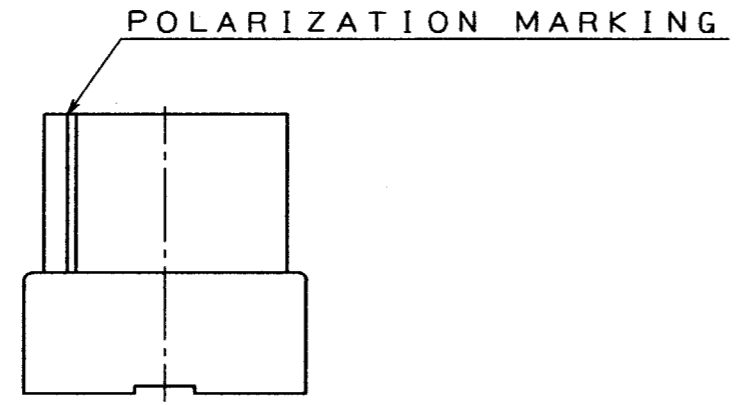
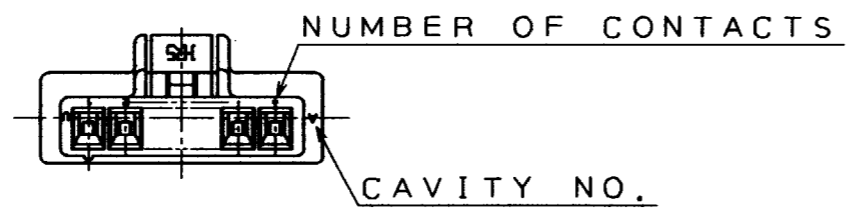
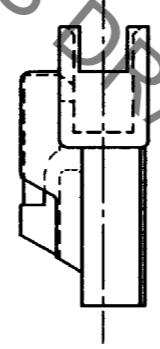
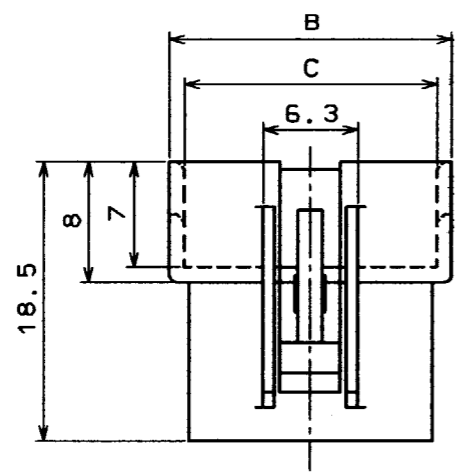
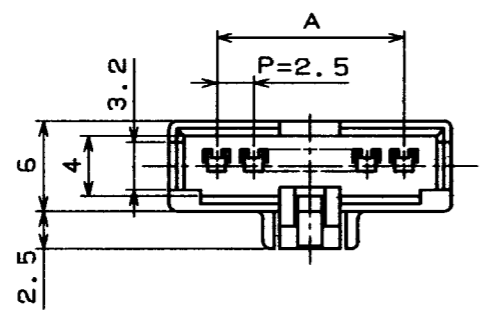

HRS DRAWING FOR PRELIMINARY

UNIT: (mm)

| HRS NO. | PART NO. | A | B | C |
|--------------|-----------------|------|------|------|
| CL541-0332-7 | DF1B- 2EP-2.5RC | 2.5 | 8.9 | 6.7 |
| CL541-0333-0 | DF1B- 3EP-2.5RC | 5.0 | 11.4 | 9.2 |
| CL541-0334-2 | DF1B- 4EP-2.5RC | 7.5 | 13.9 | 11.7 |
| CL541-0335-5 | DF1B- 5EP-2.5RC | 10.0 | 16.4 | 14.2 |
| CL541-0336-8 | DF1B- 6EP-2.5RC | 12.5 | 18.9 | 16.7 |
| CL541-0337-0 | DF1B- 7EP-2.5RC | 15.0 | 21.4 | 19.2 |
| CL541-0338-3 | DF1B- 8EP-2.5RC | 17.5 | 23.9 | 21.7 |
| CL541-0339-6 | DF1B- 9EP-2.5RC | 20.0 | 26.4 | 24.2 |
| CL541-0340-5 | DF1B-10EP-2.5RC | 22.5 | 28.9 | 26.7 |
| CL541-0341-8 | DF1B-11EP-2.5RC | 25.0 | 31.4 | 29.2 |
| CL541-0342-0 | DF1B-12EP-2.5RC | 27.5 | 33.9 | 31.7 |
| CL541-0343-3 | DF1B-13EP-2.5RC | 30.0 | 36.4 | 34.2 |

| | | | | | |
|------------------------------|--|-------------------------|----------------------------------|---------------|--------------------|
| NO. MATERIAL FINISH, REMARKS | | 1 | POLYAMIDE NATURAL(WHITE) UL94V-0 | | |
| CODE NO. (OLD) | | NO. | MATERIAL FINISH, REMARKS | | |
| | | DRAWN | DESIGNED | CHECKED | APPROVED |
| | | <i>M. Gotoh</i> | <i>M. Gotoh</i> | <i>J. Oma</i> | <i>H. Yamamoto</i> |
| | | '94. 3. 24 | '94. 3. 24 | '94. 3. 25 | '94. 3. 25 |
| DRAWING NO. EDC3-160055-01 | | PART NO. DF1B-*EP-2.5RC | | | |
| SCALE 2:1 | | CODE NO. 0332 7 | | 1 | |
| UNITS mm | | CL541- 0343 - 3 | | 1 | |

| |
|----|
| TO |
| |
| |
| |

