



ABS22 THRU ABS210

SCHOTTKY BRIDGE DIODE

2.0A SCHOTTKY BRIDGE RECTIFIER

DESCRIPTION

The UTC **ABS22 THRU ABS210** is a schottky bridge rectifier, it uses UTC's advanced technology to provide customers with high surge current capability and low forward voltage drop, etc.

The UTC **ABS22 THRU ABS210** is suitable for surface mount application.

FEATURES

- * Glass passivated die construction
- * Low forward voltage drop
- * High current capability
- * High surge current capability
- * Designed for surface mount application

SYMBOL

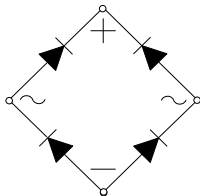

ORDERING INFORMATION

Ordering Number	Package	Packing
ABS22G-ABS-R	ABS	Tape Reel
ABS24G-ABS-R	ABS	Tape Reel
ABS26G-ABS-R	ABS	Tape Reel
ABS28G-ABS-R	ABS	Tape Reel
ABS210G-ABS-R	ABS	Tape Reel

<p>ABS22G-ABS-R</p> <p>(1) Packing Type</p> <p>(2) Package Type</p> <p>(3) Green Package</p>	<p>(1) R: Tape Reel</p> <p>(2) ABS: ABS</p> <p>(3) G: Halogen Free and Lead Free</p>
--	--

MARKING

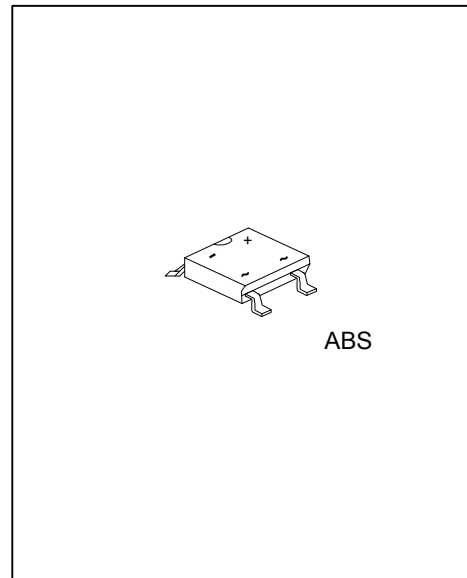
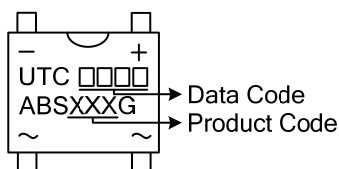

ABS22 THRU ABS210

SCHOTTKY BRIDGE DIODE

■ ABSOLUTE MAXIMUM RATINGS ($T_A=25^{\circ}\text{C}$, unless otherwise specified)

Single Phase, half wave, 60Hz, resistive or inductive load.

For capacitive load, derate current by 20%.

PARAMETER	SYMBOL	RATINGS					UNIT
		ABS22	ABS24	ABS26	ABS28	ABS210	
Peak Repetitive Reverse Voltage	V_{RRM}	200	400	600	800	1000	V
Working Peak Reverse Voltage	V_{RWM}	200	400	600	800	1000	V
DC Blocking Voltage	V_{DC}	200	400	600	800	1000	V
RMS Voltage	V_{RMS}	140	280	420	560	700	V
Average Rectified Output Current	I_O	2					A
Peak Forward Surge Current, 8.3ms Single Half Sine-Wave Superimposed on Rated Load	I_{FSM}	60					A
Operating Junction Temperature Range	T_J	-55 ~ +150					$^{\circ}\text{C}$
Storage Temperature Range	T_{STG}	-55 ~ +150					$^{\circ}\text{C}$

Note: Absolute maximum ratings are those values beyond which the device could be permanently damaged. Absolute maximum ratings are stress ratings only and functional device operation is not implied.

■ THERMAL DATA

PARAMETER	SYMBOL	RATINGS	UNIT
Junction to Ambient	θ_{JA}	62.5	$^{\circ}\text{C}/\text{W}$

Note: Measured at 1.0 MHz and applied reverse voltage of 4.0V D.C.

■ ELECTRICAL CHARACTERISTICS ($T_A=25^{\circ}\text{C}$ unless otherwise noted)

PARAMETER	SYMBOL	TEST CONDITIONS	MIN	TYP	MAX	UNIT
Forward Voltage Per Element	V_F	$I_F=1.0\text{A}$			0.95	V
		$I_F=2.0\text{A}$			1.0	V
Peak Reverse Current at Rated DC Blocking Voltage	I_R	$T_A=25^{\circ}\text{C}$			5.0	μA
		$T_A=125^{\circ}\text{C}$			200	μA

TYPICAL CHARACTERISTICS

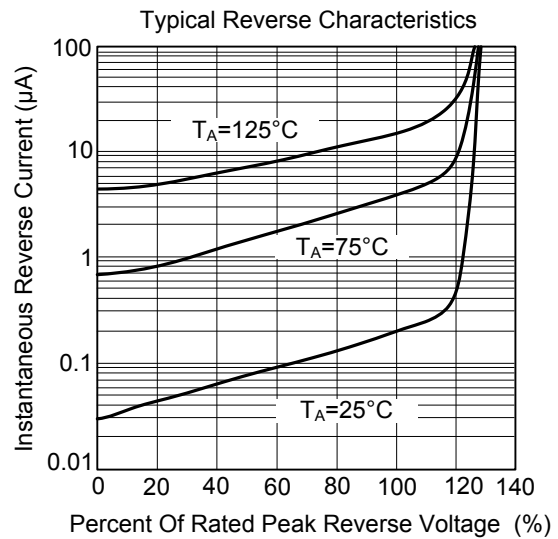
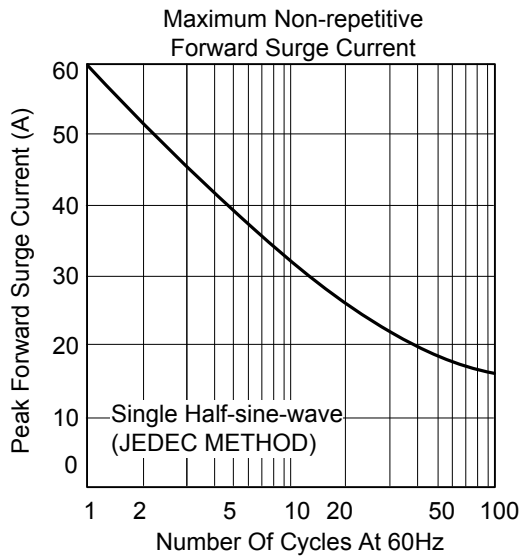
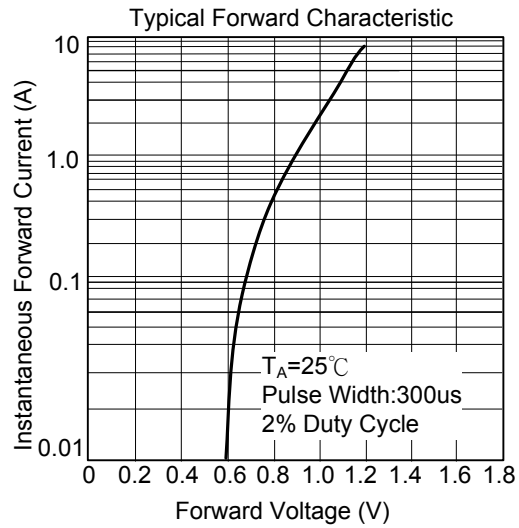
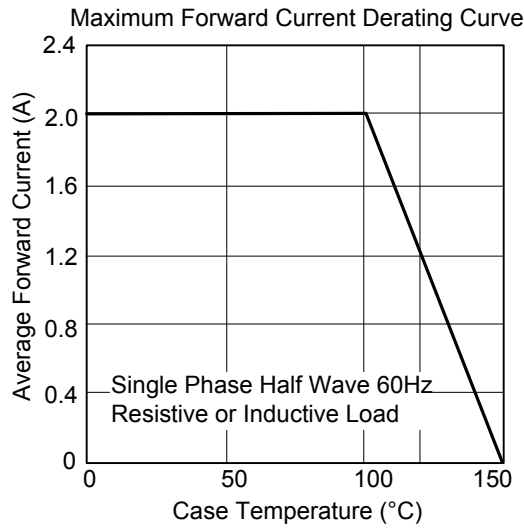

UTC assumes no responsibility for equipment failures that result from using products at values that exceed, even momentarily, rated values (such as maximum ratings, operating condition ranges, or other parameters) listed in products specifications of any and all UTC products described or contained herein. UTC products are not designed for use in life support appliances, devices or systems where malfunction of these products can be reasonably expected to result in personal injury. Reproduction in whole or in part is prohibited without the prior written consent of the copyright owner. The information presented in this document does not form part of any quotation or contract, is believed to be accurate and reliable and may be changed without notice.