

Product Description

The PE42660 is a HaRP™-enhanced SP6T RF Switch developed on the UltraCMOS™ process technology. It addresses the specific design needs of the Quad-Band GSM Handset Antenna Switch Module Market. On-chip CMOS decode logic facilitates three-pin low voltage CMOS control, while high ESD tolerance of 1500 V at all ports, no blocking capacitor requirements, and on-chip SAW filter over-voltage protection devices make this the ultimate in integration and ruggedness.

Peregrine's HaRP™ technology enhancements deliver high linearity and exceptional harmonics performance. It is an innovative feature of the UltraCMOS™ process, providing performance superior to GaAs with the economy and integration of conventional CMOS.

SP6T UltraCMOS™ 2.75 V Switch
100 – 3000 MHz

Features

- Three pin CMOS logic control with integral decoder/driver
- Exceptional harmonics performance: $2f_o = -88$ dBc and $3f_o = -85$ dBc
- Low TX insertion loss: 0.55 dB at 900 MHz, 0.65 dB at 1900 MHz
- TX – RX Isolation of 48 dB at 900 MHz, 40 dB at 1900 MHz
- 1500 V HBM ESD tolerance all ports
- 41 dBm P1dB
- No blocking capacitors required

Figure 1. Functional Diagram

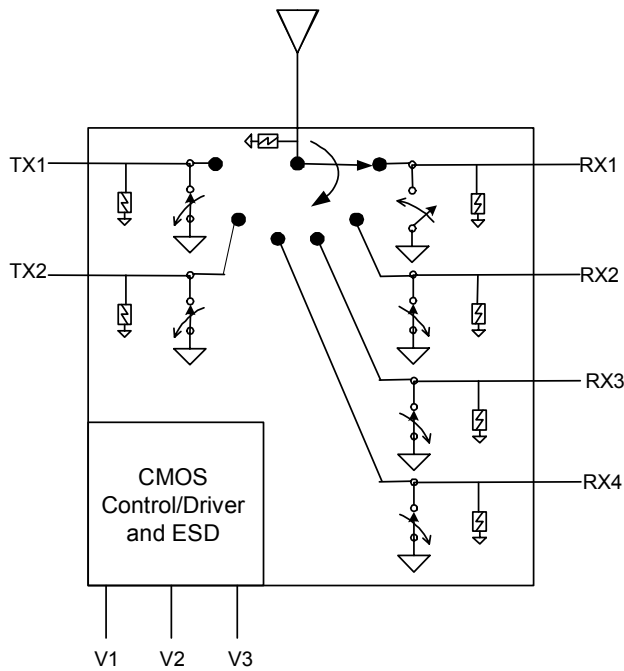

Figure 2. Die Top View

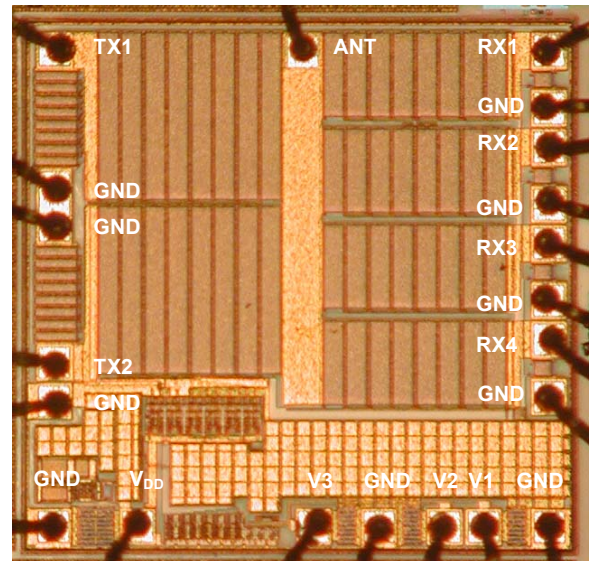

Table 1. Electrical Specifications @ +25 °C, V_{DD} = 2.75 V (Z_S = Z_L = 50 Ω)

Parameter	Conditions	Typical	Units
Operational Frequency		100-3000	MHz
Insertion Loss	ANT - TX - 850 / 900 MHz	0.55	dB
	ANT - TX - 1800 / 1900 MHz	0.65	dB
	ANT - RX - 850 / 900 MHz	0.90	dB
	ANT - RX - 1800 / 1900 MHz	1.00	dB
Isolation	TX - RX - 850 / 900 MHz	48	dB
	TX - RX - 1800 / 1900 MHz	40	dB
	TX - TX - 850 / 900 MHz	29	dB
	TX - TX - 1800 / 1900 MHz	25	dB
	ANT - TX - 850 / 900 MHz	31	dB
	ANT - TX - 1800 / 1900 MHz	25	dB
Return Loss	850 / 900 MHz	22	dB
	1800 / 1900 MHz	23	
2nd Harmonic	35 dBm TX Input - 850 / 900 MHz	-88	dBc
	33 dBm TX Input - 1800 / 1900 MHz	-85	
3rd Harmonic	35 dBm TX Input - 850 / 900 MHz	-85	dBc
	33 dBm TX Input - 1800 / 1900 MHz	-84	
Switching Time	(10-90%) (90-10%) RF	2	μs

Table 2. Operating Ranges

Parameter	Symbol	Min	Typ	Max	Units
Temperature range	T _{OP}	-40		+85	°C
V _{DD} Supply Voltage	V _{DD}	2.65	2.75	2.85	V
I _{DD} Power Supply Current (V _{DD} = 2.75 V)	I _{DD}		13	20	μA
TX input power ¹ (VSWR ≤ 3:1)	P _{IN}			+35	dBm
RX input power ¹ (VSWR ≤ 1:1)	P _{IN}			+20	dBm
Control Voltage High	V _{IH}	0.7 x V _{DD}			V
Control Voltage Low	V _{IL}			0.3 x V _{DD}	V

Note: 1. Assumes RF input period of 4620 μs and duty cycle of 50%.

Figure 3. Pin Configuration (Top View)

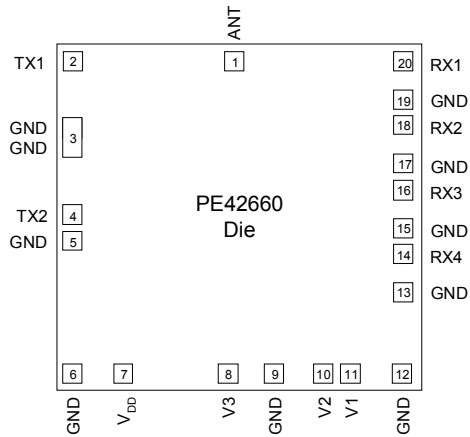

Table 3. Pin Descriptions

Pin No.	Pin Name	Description
1 ³	ANT	RF Common – Antenna
2 ³	TX1	RF I/O - TX1
3 ²	GND	Ground (Requires two bond wires)
4 ³	TX2	RF I/O – TX2
5 ²	GND	Ground
6 ²	GND	Ground
7	V _{DD}	Supply
8	V3	Switch control input, CMOS logic level
9 ²	GND	Ground
10	V2	Switch control input, CMOS logic level
11	V1	Switch control input, CMOS logic level
12 ²	GND	Ground
13 ²	GND	Ground
14 ³	RX4	RF I/O – RX4
15 ²	GND	Ground
16 ³	RX3	RF I/O – RX3
17 ²	GND	Ground
18 ³	RX2	RF I/O – RX2
19 ²	GND	Ground
20 ³	RX1	RF I/O – RX1

Notes: 2. Bond wires should be physically short and connected to ground plane for best performance.

3. Blocking capacitors needed only when non-zero DC voltage present.

Table 4. Absolute Maximum Ratings

Symbol	Parameter/Conditions	Min	Max	Units
V _{DD}	Power supply voltage	-0.3	4.0	V
V _I	Voltage on any input	-0.3	V _{DD} + 0.3	V
T _{ST}	Storage temperature range	-65	+150	°C
P _{IN} (50 Ω)	TX input power (50 Ω) ^{4,5}		+38	dBm
	RX input power (50 Ω) ^{4,5}		+23	
P _{IN} (∞:1)	TX input power (VSWR ∞:1) ^{4,5}		+35	dBm
V _{ESD}	ESD Voltage (HBM, MIL_STD 883 Method 3015.7)		1500	V
	ESD Voltage at ANT Port (IEC 61000-4-2)		1700	V

Notes: 4. Assumes RF input period of 4620 μs and duty cycle of 50%.

5. V_{DD} within operating range specified in Table 2.

Part performance is not guaranteed under these conditions. Exposure to absolute maximum conditions for extended periods of time may adversely affect reliability. Stresses in excess of absolute maximum ratings may cause permanent damage.

Table 5. Truth Table

Path	V3	V2	V1
ANT – RX1	0	0	0
ANT – RX2	0	0	1
ANT – RX3	0	1	0
ANT – RX4	0	1	1
ANT - TX1	1	0	x
ANT - TX2	1	1	x

Electrostatic Discharge (ESD) Precautions

When handling this UltraCMOS™ device, observe the same precautions that you would use with other ESD-sensitive devices. Although this device contains circuitry to protect it from damage due to ESD, precautions should be taken to avoid exceeding the specified rating.

Latch-Up Avoidance

Unlike conventional CMOS devices, UltraCMOS™ devices are immune to latch-up.

Evaluation Kit

The SP6T Evaluation Kit board was designed to ease customer evaluation of the PE42660 RF switch.

The PE42660 has two high power TX ports and four high isolation RX ports. The TX ports are symmetric and are designed as paths for the 850, 900, 1800, or 1900 MHz bands. The RX ports are also symmetric and can be assigned to any of these frequency bands.

The ANT port connects through a 50 Ω transmission line to the top SMA connector, J1. The RX and TX ports connect through 50 Ω transmission lines to SMA connectors J2 – J7. A through 50 Ω transmission line between SMA connectors J9 and J10 allows estimation of the PCB losses over environmental conditions. An open transmission line connected to J11 is also provided.

J8 supplies DC power to the pin marked V_{DD} and the bottom row of pins, which is GND. 1 MΩ pull-up resistors are connected from V_{DD} to each of the three control logic inputs: V1, V2, and V3. These pull-up resistors are provided for ease of evaluation on this board and are not required for the PE42660 to operate.

Adding a jumper between a control pin and the adjacent GND pin on the bottom row of J8 will set a logic-0 on that control pin. Removing the jumper will set a logic-1. To evaluate the PE42660, add or remove jumpers according to the truth table in Table 5.

Figure 4. Evaluation Board Layout

Peregrine Specification 101/0205

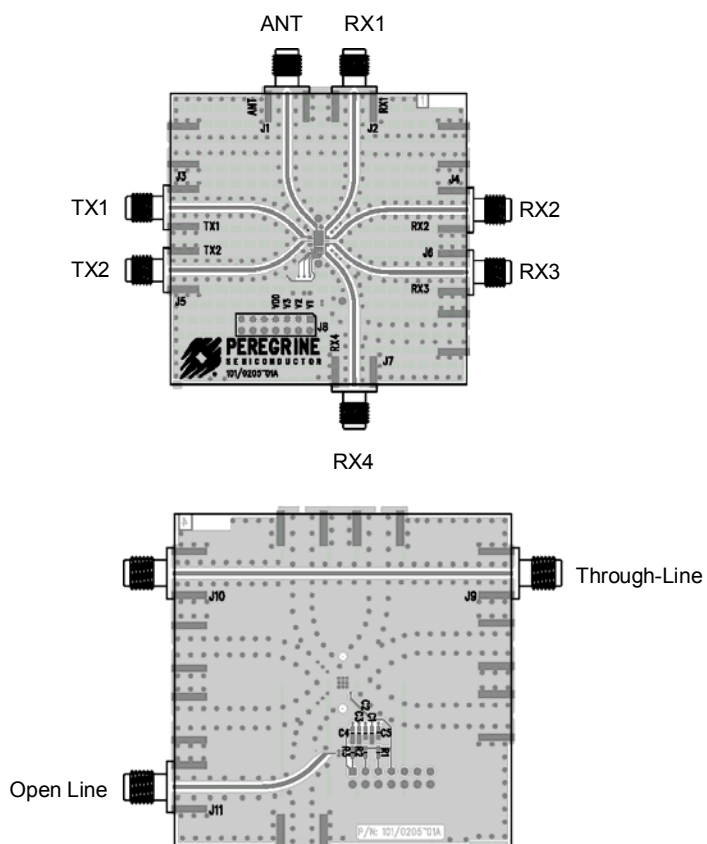
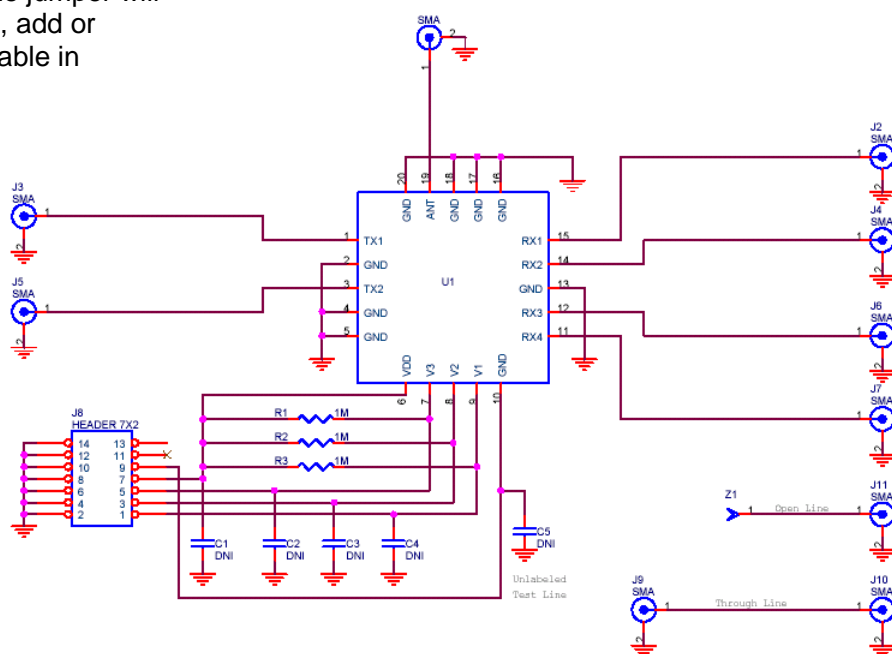

Figure 5. Evaluation Board Schematic

Peregrine Specification 102/0267



Electrical Test and Performance Specifications

PE42660 dice are 100% electrically tested for the parameters listed below from Table 1 and Table 2. All other parameters are guaranteed through design and characterization.

- Insertion Loss (all ports)
- TX1 & TX2 Harmonics
- TX – RX Isolation
- I_{DD} supply current
- Control pin leakages

Wafer and Die Packaging

Peregrine Semiconductor has two methods for shipping dice to our customers. The shipping option used is based on the customer's requirements and the number of dice.

Peregrine offers product dice in two packaging options: Standard Die Carrier Packages (waffle pack) and dice on Film Frames.

Wafer Mount/Dicing

In preparation for dicing, wafers are thinned and polished and 100% electrically probed prior to mounting on film frame tape and rings. Figure 6 shows a wafer mounted on film frame using PVC backed mounting tape. In preparation for shipment, wafers are visually inspected after singulation and shipped with an electronic map file providing good dice locations.

Storage and Preservation

Proper storage conditions are necessary to prevent product contamination and/or degradation after shipment.

Product should be stored in the original unopened packaging or, once opened, in a nitrogen purged cabinet at room temperature (45% + 15% relative humidity controlled environment).

Singulated wafers mounted on film frames are intended for immediate use and have a limited shelf life. This is primarily due to the nature of the adhesive tape used for mounting the product. This product can be stored up to 30 days. This applies whether or not the material has remained in its original sealed container. To reduce the risk of contamination or degradation, it is recommended that product not being used in the assembly process be returned to their original containers and resealed with a vacuum seal process.

Figure 6. Wafer on Film Frame

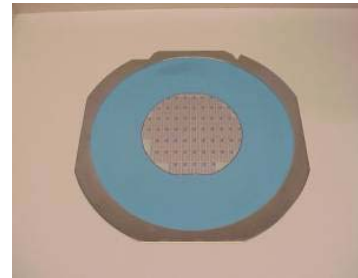

Figure 7. Dice and Wafer Processing Flow

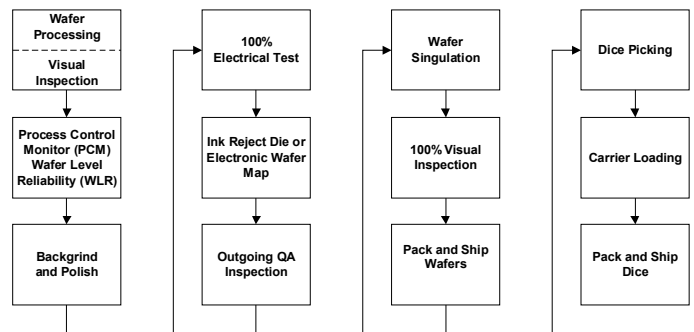

Figure 8. Waffle Pack



Standard Die Carrier Package/Waffle Pack

Waffle packs are available to customers during product development and prototyping phase only. Orders will move to film frames at production launch or for large quantity requirements.

Dice have been 100% electrically probed, singulated, visually inspected and are packaged in a 2"x2" waffle pack (400 dice per waffle pack).

Die Handling

All die products must be handled only at ESD safe workstations using standard ESD precautions. It is recommended that the die be handled only in a class 10,000 or better designated clean room environment.

Singulated dice are not to be handled with tweezers. A vacuum wand with a non-metallic ESD protected tip must be used.

Recommended Dice Assembly Procedure

Cleaning

Dice do not require cleaning prior to assembly.

Die Attach

The PE42660 die substrate is sapphire – the recommended die attach operation for sapphire is epoxy die attach adhesive. An eutectic die attach method does not work with sapphire substrates.

Bonding

Thermo compression gold ball or aluminum ultrasonic bonding may be used. The ball should cover the bonding pad, but not excessively, or it may short out the surrounding metallization. Aluminum or gold 1-mil wire is recommended. Note the bonding pad material is aluminum.

Shipping Method

Standard die carrier packages and wafer film frames are placed in a wafer container and then vacuum-sealed inside an ESD shielded bag. Sealed product is then placed inside a corrugated cardboard box surrounded by bubble wrap or foam for maximum protection during shipment.

Table 6. Mechanical Specifications

Parameter	Minimum	Typical	Maximum	Units	Test Conditions
Die Size (x,y)		1.146 x 1.106		mm	As drawn
Die Size (x,y)		1.25 x 1.21		mm	Including excess sapphire, max. tolerance = ±0.1mm in either dimension
Wafer Thickness	180	200	220	µm	
Wafer Size		150		mm	

Table 7. Pad Coordinates

All pad locations originate from the die center and refer to the center of the pad.

All pad openings are 60 x 60 µm except for Pad #3 which is 140 x 60 µm. Minimum pad pitch is 80 µm.

Note 1. - Double pad, requires two bond wires.

Pad #	Pad Name	Pad Center (µm)	
		X	Y
1	ANT	1.9	488.1
2	TX1	-511.3	491.3
3	GND ¹	-511.3	168.9
4	TX2	-511.3	-153.5
5	GND	-511.3	-233.5
6	GND	-511.3	-491.3
7	VDD	-337.7	-491.3
8	V3	25.7	-491.3
9	GND	160.9	-491.3
10	V2	296.1	-491.3
11	V1	376.1	-491.3
12	GND	511.3	-491.3
13	GND	511.3	-223.7
14	RX4	511.3	-105.1
15	GND	511.3	-25.1
16	RX3	511.3	93.5
17	GND	511.3	173.5
18	RX2	511.3	292.1
19	GND	511.3	372.1
20	RX1	511.3	490.7

Figure 9. Pad Numbering

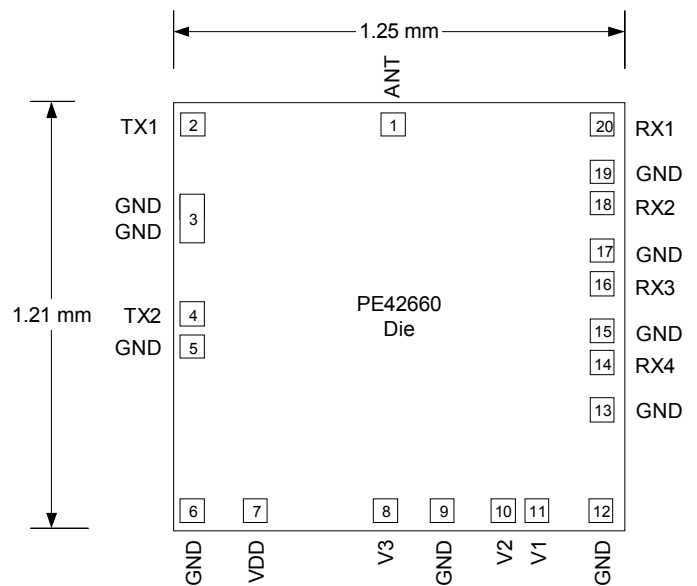

ESD Protection Circuit

Handset products must tolerate large ESD surges at the antenna interface without damage. The IEC 61000-4-2 standard specifies both 8 kV contact and 16 kV air discharges that typical handsets must survive. By itself, the PE42660 offers protection to 1.5 kV but with the addition of two inexpensive passive components, the switch can meet the levels as specified in the IEC spec. Figure 10 is the suggested solution for compliance with the IEC standards.

Figure 10. ESD Protection Circuit

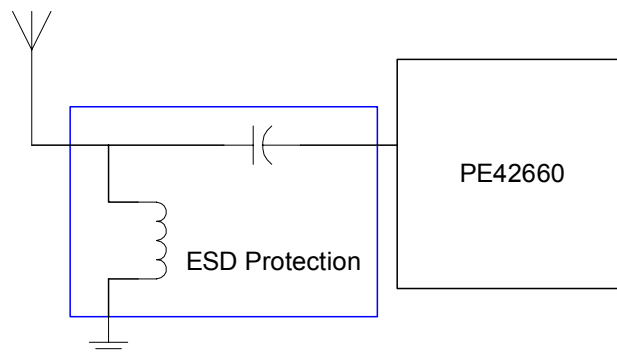

L = 27 nH (muRata: LQG1127NJ00),

C = 33 pF (muRata: GRM33C0G330J50)

Table 8. PE42660 Antenna Application Test Results (C=150 pF, R=330 Ω, IEC 61000-4-2 Standard)

Test Condition	Results
+8 kV contact discharge, 10 times with 1s intervals	Pass
-8 kV contact discharge, 10 times with 1s intervals	Pass
+16 kV air discharge, 10 times with 1s intervals	Pass
-16 kV air discharge, 10 times with 1s intervals	Pass

Table 9. Ordering Information

Order Code	Die ID	Description	Package	Shipping Method
42660-90	C9807_01	PE42660-DIE-D	Film Frame	Wafer (Gross Die / Wafer Quantity)
42660-99	C9807_01	PE42660-DIE-400G	Waffle Pack	400 Dice / Waffle Pack
42660-00	C9807_01	PE42660-DIE-1H	Evaluation Kit	1/ box

Sales Offices

The Americas

Peregrine Semiconductor Corp.

9450 Carroll Park Drive
San Diego, CA 92121
Tel 858-731-9400
Fax 858-731-9499

Europe

Peregrine Semiconductor Europe

Commercial Products:

Bâtiment Maine
13-15 rue des Quatre Vents
F- 92380 Garches, France
Tel: +33-1-47-41-91-73
Fax : +33-1-47-41-91-73

Space and Defense Products:

180 Rue Jean de Guiramand
13852 Aix-En-Provence cedex 3, France
Tel: +33(0) 4 4239 3361
Fax: +33(0) 4 4239 7227

North Asia Pacific

Peregrine Semiconductor K.K.

5A-5, 5F Imperial Tower
1-1-1 Uchisaiwaicho, Chiyoda-ku
Tokyo 100-0011 Japan
Tel: +81-3-3502-5211
Fax: +81-3-3502-5213

South Asia Pacific

Peregrine Semiconductor

28G, Times Square,
No. 500 Zhangyang Road,
Shanghai, 200122, P.R. China
Tel: +86-21-5836-8276
Fax: +86-21-5836-7652

For a list of representatives in your area, please refer to our Web site at: www.psemi.com

Data Sheet Identification

Advance Information

The product is in a formative or design stage. The data sheet contains design target specifications for product development. Specifications and features may change in any manner without notice.

Preliminary Specification

The data sheet contains preliminary data. Additional data may be added at a later date. Peregrine reserves the right to change specifications at any time without notice in order to supply the best possible product.

Product Specification

The data sheet contains final data. In the event Peregrine decides to change the specifications, Peregrine will notify customers of the intended changes by issuing a DCN (Document Change Notice).

The information in this data sheet is believed to be reliable. However, Peregrine assumes no liability for the use of this information. Use shall be entirely at the user's own risk.

No patent rights or licenses to any circuits described in this data sheet are implied or granted to any third party.

Peregrine's products are not designed or intended for use in devices or systems intended for surgical implant, or in other applications intended to support or sustain life, or in any application in which the failure of the Peregrine product could create a situation in which personal injury or death might occur. Peregrine assumes no liability for damages, including consequential or incidental damages, arising out of the use of its products in such applications.

The Peregrine name, logo, and UTSi are registered trademarks and UltraCMOS and HaRP are trademarks of Peregrine Semiconductor Corp.