



## C555

Preliminary

CMOS IC

### SINGLE TIMER

#### DESCRIPTION

The **C555** astable and monostable timing circuit is a highly stable controller capable of producing accurate time delays, or oscillation.

#### FEATURES

- \* Timing from microseconds through hours
- \* High speed operation – 500kHz
- \* Wide operation supply voltage range – 2 to 18 voltages
- \* Low Supply Current – 0.2mA
- \* Operates in both astable and monostable modes
- \* High output source/sink driver can drive TTL / CMOS
- \* Adjustable duty cycle

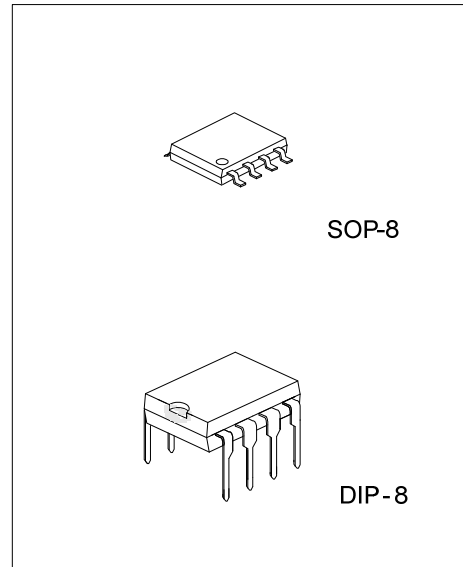

#### ORDERING INFORMATION

Ordering Number		Package	Packing
Lead Free	Halogen Free		
C555L-D08-T	C555G-D08-T	DIP-8	Tube
C555L-S08-T	C555G-S08-T	SOP-8	Tube
C555L-S08-R	C555G-S08-R	SOP-8	Tape Reel

<p>C555L-D08-T</p> <p>(1)Packing Type (2)Package Type (3)Lead Free</p>	<p>(1) T: Tube, R: Tape Reel (2) D08: DIP-8, S08: SOP-8 (3) L: Lead Free, G: Halogen Free</p>
--	---

■ PIN CONFIGURATION

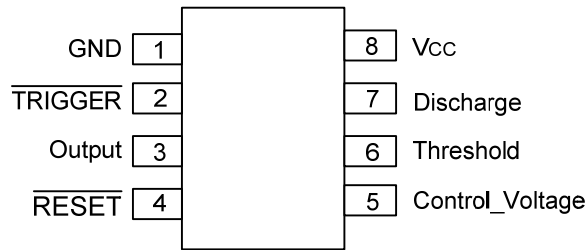

■ PIN DESCRIPTION

PIN No.	PIN NAME	DESCRIPTION
1	GND	Ground
2	TRIGGER	Trigger voltage input
3	Output	Output
4	RESET	Direct reset low input
5	Control_Voltage	Control voltage
6	Threshold	Threshold voltage input
7	Discharge	Discharging when output is low
8	V <sub>CC</sub>	Supply voltage

■ TRUTH TABLE

THRESHOLD	TRIGGER	RESET	OUTPUT	DISCHARGE
X	X	L	L	ON
$>2/3 \times V_{CC}$	$>1/3 \times V_{CC}$	H	L	ON
$<2/3 \times V_{CC}$	$>1/3 \times V_{CC}$	H	STABLE	STABLE
X	$<1/3 \times V_{CC}$	H	H	OFF

■ BLOCK DIAGRAM

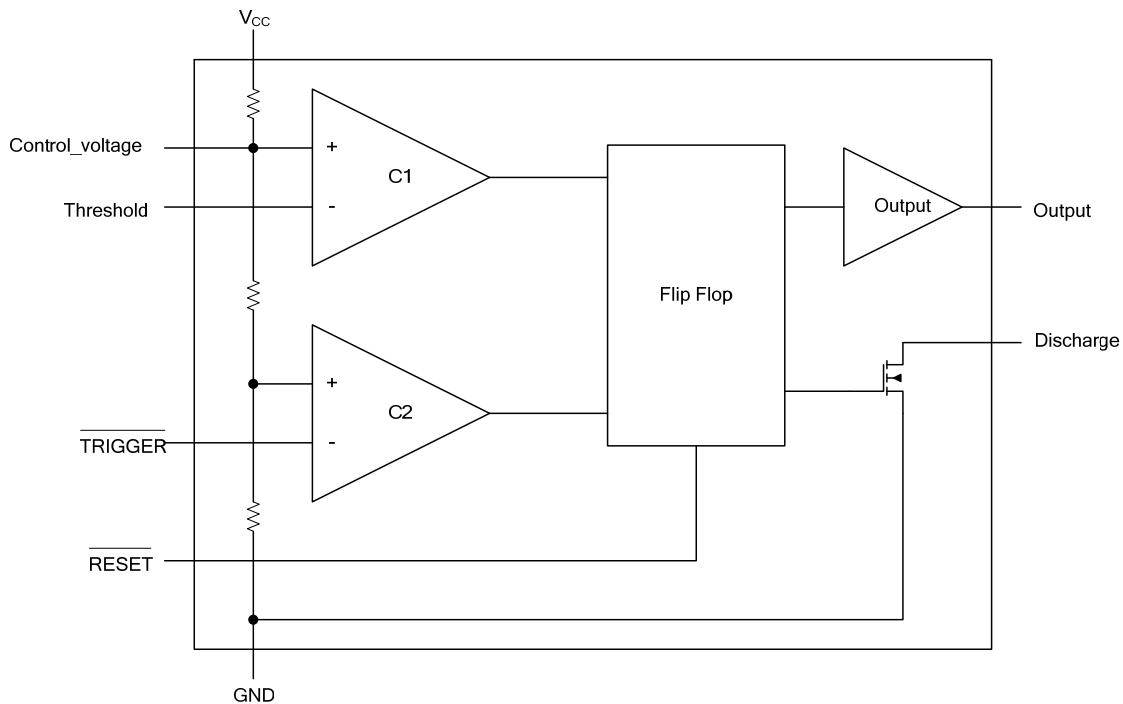

### ■ ABSOLUTE MAXIMUM RATINGS

PARAMETER	SYMBOL	RATINGS	UNIT
Supply Voltage	$V_{CC}$	18	V
Input Voltage	$V_{TH}, V_{TRIG}, V_{RST}$	$-0.3 \sim V_{CC}+0.3$	V
Output Current	$I_O$	100	mA
Power Dissipation	$P_D$	200	mW
Junction Temperature	$T_J$	125	°C
Operating Temperature	$T_{OPR}$	-20~85	°C
Storage Temperature	$T_{STG}$	-65~150	°C

Note: Absolute maximum ratings and operation rating recommended are those values beyond which the device could be permanently damaged. Absolute maximum ratings are stress ratings only and functional device operation is not implied.

### ■ RECOMMENDED OPERATING CONDITIONS

PARAMETER	SYMBOL	RATINGS	UNIT
Supply Voltage	$V_{CC}$	2.0 ~ 18	V
Output Current	$I_O$	20	mA
Operating Temperature	$T_{OPR}$	-20~75	°C

### ■ ELECTRICAL CHARACTERISTICS (unless otherwise specified)

PARAMETER	SYMBOL	TEST CONDITIONS	MIN	TYP	MAX	UNIT
<b><math>T_A=25^\circ\text{C}</math></b>						
Supply Current	$I_{CC}$	$V_{CC}=2V$			200	$\mu\text{A}$
		$V_{CC}=18V$			300	$\mu\text{A}$
Initial Accuracy	$A_{CCUR}$	$V_{CC}=5V, R_L=1\sim 100k\Omega, C_L=0.1\mu\text{F}$	5			%
Drift with Supply Voltage	$\Delta t/\Delta V_{CC}$				3	%/C
Control Voltage	$V_C$		$0.65 \times V_{CC}$		$0.69 \times V_{CC}$	V
Threshold Voltage	$V_{TH}$	$V_{CC}=5V$	$0.65 \times V_{CC}$		$0.70 \times V_{CC}$	V
Trigger Voltage	$V_{TR}$	$V_{CC}=5V$	$0.31 \times V_{CC}$		$0.36 \times V_{CC}$	V
Reset Voltage	$V_{RST}$	$V_{CC}=2\sim 18V$	0.4		1.0	V
Low Output Voltage	$V_{OL}$	$V_{CC}=5V, I_{OL}=3.2\text{mA}$			0.4	V
		$V_{CC}=15V, I_{OL}=20\text{mA}$			1.0	V
High Output Voltage	$V_{OH}$	$V_{CC}=5V, I_{OL}=0.8\text{mA}$	4.0			V
		$V_{CC}=15V, I_{OL}=0.8\text{mA}$	14.3			V
Rise/Fall Time of Output	$t_{THL}, t_{TLH}$	$V_{CC}=15V, R_L=10M\Omega, C_L=10\text{pF}$	35		75	ns
Guaranteed Max Osc Freq	$f_{MAX}$	$V_{CC}=2\sim 18V, \text{Astable Operation}$	500			kHz
<b><math>T_A=-20\sim 70^\circ\text{C}</math></b>						
Supply Current	$I_{CC}$	$V_{CC}=2V$			400	$\mu\text{A}$
		$V_{CC}=18V$			600	$\mu\text{A}$
Initial Accuracy	$A_{CCUR}$	$V_{CC}=5V, R_L=1\sim 100k\Omega, C_L=0.1\mu\text{F}$	5			%
Drift with Temperature	$\Delta t/\Delta T$	$V_{CC}=5V, R_L=1\sim 100k\Omega, C_L=0.1\mu\text{F}$	$V_{CC}=5V$		0.02	%/°C
			$V_{CC}=15V$		0.06	%/°C
Drift with Supply Voltage	$\Delta t/\Delta V_{CC}$	$C_L=0.1\mu\text{F}$			6	%/C
Control Voltage	$V_C$		$0.60 \times V_{CC}$		$0.80 \times V_{CC}$	V
Threshold Voltage	$V_{TH}$	$V_{CC}=5V$	$0.60 \times V_{CC}$		$0.80 \times V_{CC}$	V
Trigger Voltage	$V_{TR}$	$V_{CC}=5V$	$0.28 \times V_{CC}$		$0.40 \times V_{CC}$	V
Reset Voltage	$V_{RST}$	$V_{CC}=2\sim 18V$	0.2		1.5	V
Low Output Voltage	$V_{OL}$	$V_{CC}=5V, I_{OL}=3.2\text{mA}$			0.6	V
		$V_{CC}=15V, I_{OL}=20\text{mA}$			1.5	V
High Output Voltage	$V_{OH}$	$V_{CC}=5V, I_{OL}=0.8\text{mA}$	3.5			V
		$V_{CC}=15V, I_{OL}=0.8\text{mA}$	14			V
Rise/Fall Time of Output	$t_{THL}, t_{TLH}$	$V_{CC}=5V, R_L=10M\Omega, C_L=10\text{pF}$	70		150	ns
Guaranteed Max Osc Freq	$f_{MAX}$	$V_{CC}=2\sim 18V, \text{Astable Operation}$	200			kHz

■ TYPICAL APPLICATION CIRCUIT

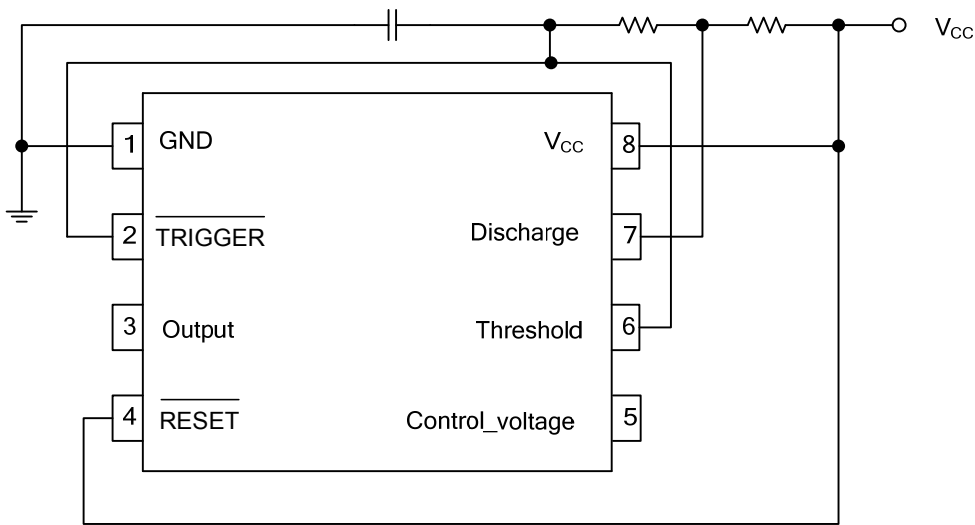

■ SWITCHING WAVEFORMS

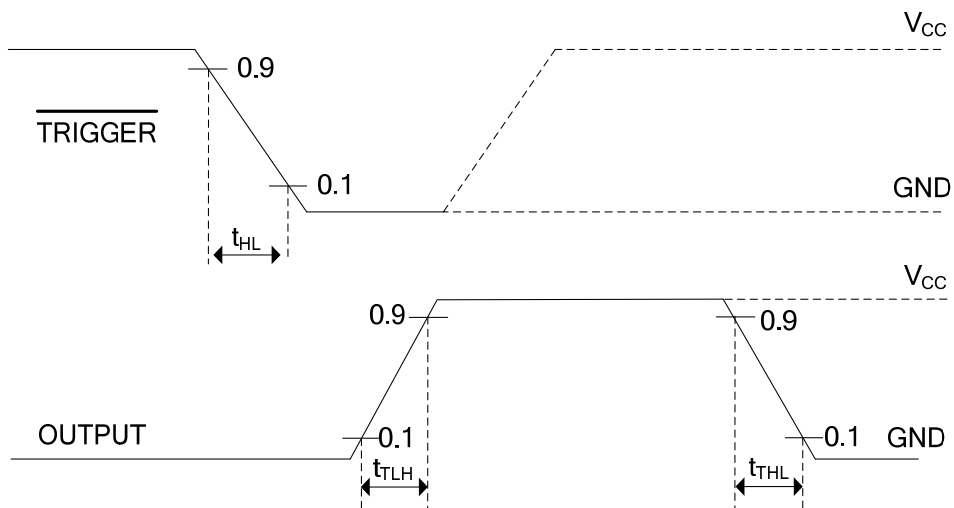

UTC assumes no responsibility for equipment failures that result from using products at values that exceed, even momentarily, rated values (such as maximum ratings, operating condition ranges, or other parameters) listed in products specifications of any and all UTC products described or contained herein. UTC products are not designed for use in life support appliances, devices or systems where malfunction of these products can be reasonably expected to result in personal injury. Reproduction in whole or in part is prohibited without the prior written consent of the copyright owner. The information presented in this document does not form part of any quotation or contract, is believed to be accurate and reliable and may be changed without notice.