

Helping Customers Innovate, Improve & Grow



### Features

- Ultra Low g-Sensitivity
- Low Phase Noise
- High Stability
- Frequency Range: 8 MHz to 15 MHz
- Standard Frequency 10 MHz
- Vibration Compensation

### Applications

- Military Avionics
- Airborne Radar
- Test Equipment
- Frequency Synthesizers
- Position Location
- Satellite Communications

### Performance Specifications

Parameter	Min	Typ	Max	Units	Condition
Available Frequencies					
Frequency Range	8		15	MHz	
G-Sensitivity Performance					
Standard crystal			1	ppb/g	
G Sensitivity w\ Low g-Crystal			0.2	ppb/g	
G Sensitivity w\ Low g-Crystal & Vibration compensation			0.02	ppb/g	Degrades to 0.2 ppb/g above 250 Hz
(No mechanical resonances out to 2KHz)					G sensitivity specified per axis
For oscillators with 0.1 ppb/g out to 2 KHz contact factory.					
Frequency Stabilities <sup>1</sup>					
(Stabilities listed for 10 MHz. For Stabilities above 10 MHz values may degrade. Please contact factory.)					
vs. Operating Temperature Range (referenced to +25°C)	-30		+30	ppb	-40... +85°C
	-20		+20	ppb	-40... +70°C
	-10		+10	ppb	-20... +70°C
	-5		+5	ppb	0... +70°C
Initial Tolerance	-50		+50	ppb	at time of shipment, nominal EFC
vs. Supply Voltage Change	-2.0		+2.0	ppb	Vs ± 5%
vs. Load Change	-2.0		+2.0	ppb	Load ± 5%
vs. Aging / Daily	-0.5		+0.5	ppb	after 72 hours of operation
vs. Aging / 1 <sup>st</sup> Year	-40		+40	ppb	after 72 hours of operation
vs. Aging / Year (following years)	-30		+30	ppb	
Retrace <sup>2</sup>	-20		+20	ppb	

## Performance Specifications

Parameter	Min	Typ	Max	Units	Condition
<b>Supply Voltage (Vs)</b>					
Supply voltage	14.25	15.0	15.75	VDC	18 & 24 VDC options available
	11.25	12.0	12.75	VDC	18 & 24 VDC options available
Oven Power Consumption			10.0	Watts	during warm-up all temperatures
			3.0	Watts	steady state @ +25°C
			7.0	Watts	steady state @ -40°C
			1.0	Watts	steady state @ +70°C
<b>RF Output</b>					
Start Time		1	2	s	time required to achieve 90% of amplitude
Signal	Sinewave				
Load		50		Ohm	
Output Power	+6.0	+7.0	+8.0	dBm	
Harmonics			-30	dBc	
<b>Frequency Tuning (EFC)</b>					
Tuning Range	±0.5	±0.8	±2.0	ppm	Electronic frequency control
Linearity			20	%	
Tuning Slope	Positive				
Control Voltage Range	0.0	+4.0	+8.0	VDC	
Input Impedance	20			kOhm	
Modulation Bandwidth	150			Hz	
<b>Mechanical Trim (Internal)</b>					
Tuning Range	±0.75	±1.0	±2.0	ppm	Internal Mechanical
<b>Phase Noise</b>					
Phase Noise <sup>3</sup> standard(@ 10 MHz) (under static conditions - no vibration)		-100	-95	dBc/Hz	1 Hz
		-130	-127	dBc/Hz	10 Hz
		-155	-152	dBc/Hz	100 Hz
		-166	-163	dBc/Hz	1 KHz
		-168	-165	dBc/Hz	10 KHz
Phase Noise <sup>3</sup> Low Noise option (@ 10 MHz) (under static conditions - no vibration)			-105	dBc/Hz	1 Hz
			-135	dBc/Hz	10 Hz
			-157	dBc/Hz	100 Hz
			-167	dBc/Hz	1 KHz
			-170	dBc/Hz	10 KHz

Parameter	Min	Typ	Max	Units	Condition
<b>Additional Parameters<sup>1</sup></b>					
Weight			150	g	
<b>Absolute Maximum Ratings</b>					
Supply voltage (Vs)			28	V	
Output Load	25		open	ohm	
Operable Temperature Range	-55		+85	°C	
<b>Environmental Specifications</b>					
Shock (Operating)	MIL-STD-202, Method 213, Condition J, 30G, 11ms, half sine				
Shock (Endurance)	Mil-STD-202, Method 213, Condition C, 100G, 6ms, half sine				
Sine Vibration (Operating)	Mil-STD-202, Method 204, Condition C, 10 G				
Sine Vibration (Endurance)	Mil-STD-202, Method 204, Condition D, 20 G				
Random Vibration (Operating)	Mil-STD-202, Method 214, Condition I-C, 9.26 Grms, 3-5min/axis (without vibe comp) Mil-STD-202, Method 214, Condition I-A, 5.35 Grms, 3-5min/axis (with vibe comp)				
Random Vibration (Endurance)	Mil-STD-202, Method 214, Condition I-H, 29.28 Grms, 3hrs/axis				
Seal	Nonhermetic - Mil-STD-202, Method 112, Condition D available only as custom part number - please contact factory				
Humidity	MIL-STD-202, Method 103, Condition B, 90% rh				
Altitude	MIL-STD-202, Method 105, sea level to 30,000 ft				
Resistance to Soldering Heat	MIL-STD-202, Method 210, Condition A,B,C				
RoHS	not RoHS compliant				
Terminal Strength	MIL-STD-202, Method 211, Condition C (5 bends at 45°, 2 lbs)				
Moisture Sensitivity Level	1				
Storage Temperature Range	-55		+125	°C	

# Outline Drawing / Enclosure

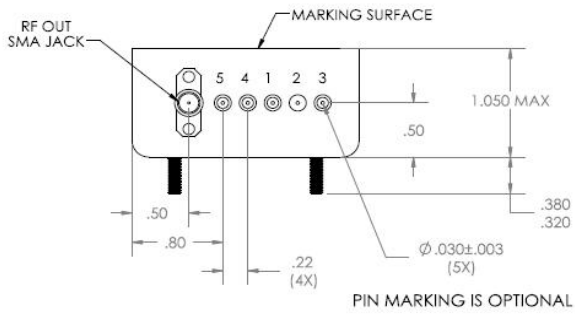

Dimensions in inches

Package configuration A		
ordering code	Height "H"	
5	0.80	
0	1.05	

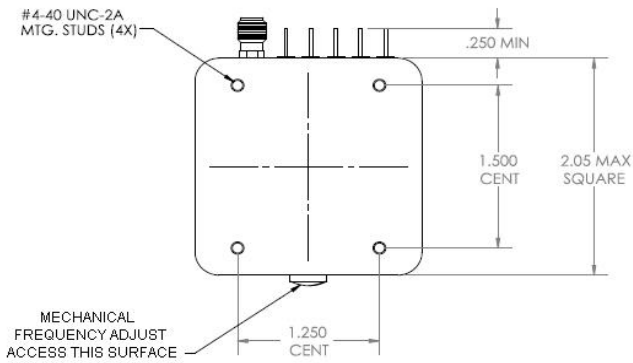

Pin Connections	
1	Electronic Frequency Control (EFC)
2	Ground (Case)
3	Supply Voltage
4	Vectron Internal Use Only / NC
5	Vectron Internal Use Only / NC

# Outline Drawing / Enclosure

Dimensions in inches

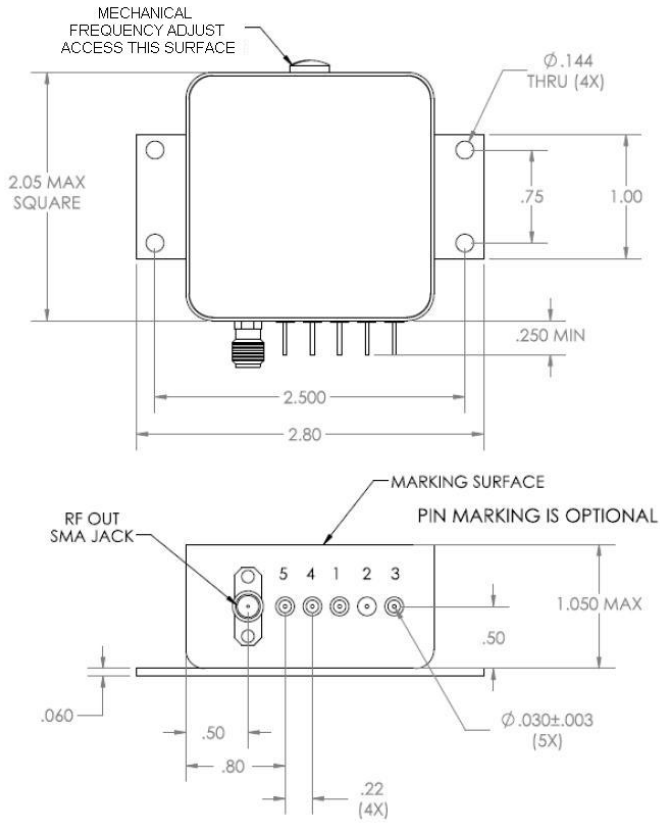

Package configuration C		
ordering code	Height "H"	
7	0.80	
2	1.05	

Pin Connections	
1	Electronic Frequency Control (EFC)
2	Ground (Case)
3	Supply Voltage
4	Vectron Internal Use Only / NC
5	Vectron Internal Use Only / NC

## Ordering Information<sup>4</sup>

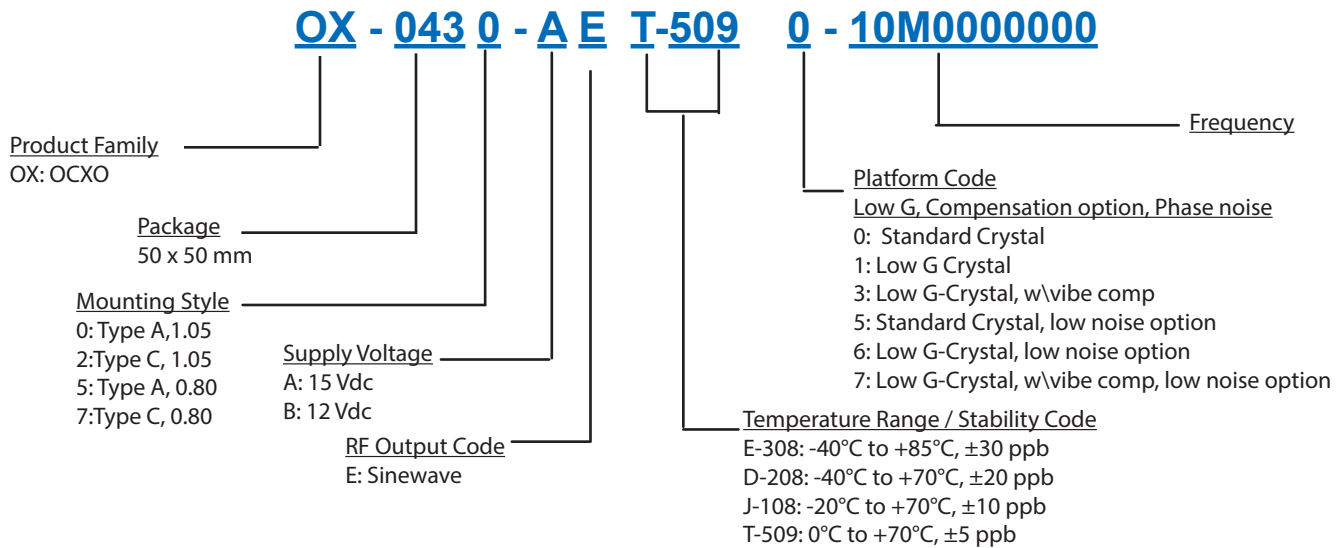

## Additional Ordering Options

Additional ordering options available include custom temperature ranges, custom temperature stabilities, custom phase noise requirements, custom height, custom supply voltage, hermetic option, and improved g-sensitivity. These modifications require a custom dash number - please contact the factory for additional information.

## Design Tools

Vectron stocks the following items for small orders and prototype development:
OX-0437-AEE-3087-10M000000
Vectron stocks the following evaluation board for this product:
None
Application Notes:
None

### Notes:

1. Unless otherwise stated, all values are valid after warm-up time and refer to typical conditions for supply voltage, frequency control voltage, load, and temperature (25°C).
2. Retrace is defined as the frequency difference between the end of two 24 hour on power periods with a 24 hour off period in between while at a constant temperature.
3. Phase noise degrades with increasing output frequency.
4. Not all options and codes available at all frequencies.

## For Additional Information, Please Contact

### USA:

Vectron International  
267 Lowell Road, Unit 102  
Hudson, NH 03051  
Tel: 1.888.328.7661  
Fax: 1.888.329.8328

### Europe:

Vectron International  
Landstrasse, D-74924  
Neckarbischofsheim, Germany  
Tel: +49 (0) 3328.4784.17  
Fax: +49 (0) 3328.4784.30

### Asia:

Vectron International  
68 Yin Cheng Road(C), 22nd Floor  
One LuJiaZui  
Pudong, Shanghai 200120, China  
Tel: +86 21 6194 6886  
Fax: +86 21 6194 6699

### Disclaimer

Vectron International reserves the right to make changes to the product(s) and or information contained herein without notice. No liability is assumed as a result of their use or application. No rights under any patent accompany the sale of any such product(s) or information.

Rev: 11/24/2014 jar