

S-D

REVISIONS

ISSUE	CHANGES
1	CN 23977 C GIG 27 APR 83

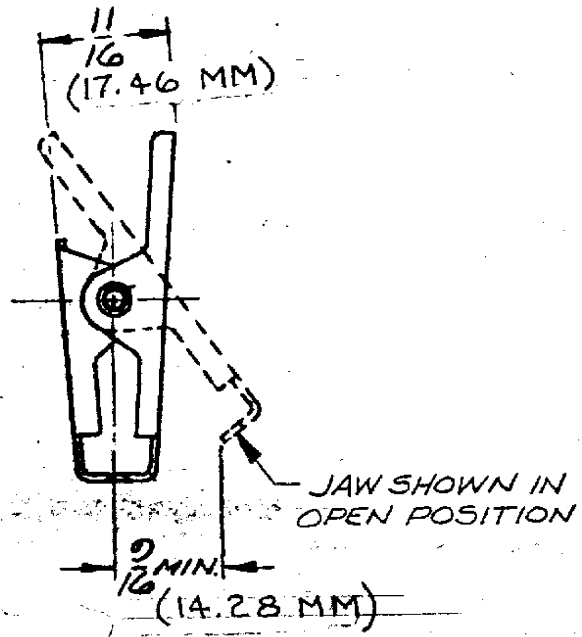
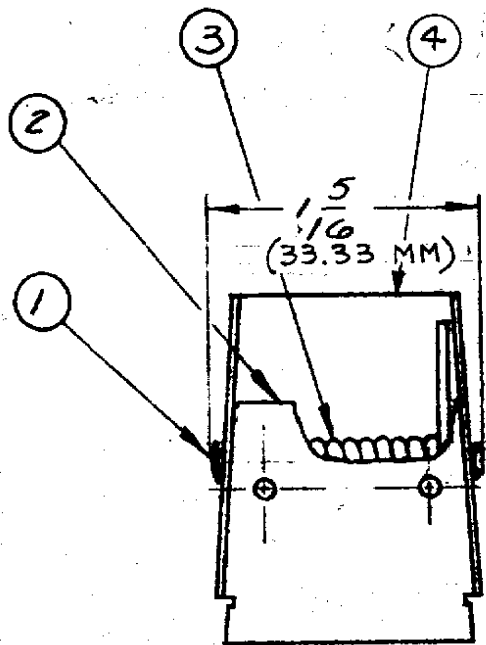

4	1	CLIP BODY	
3	1	SPRING	
2	1	CLIP BODY	
1	1	RIVET	
ITEM	REQD	DESCRIPTION	DRAWING NO

REF:
FINISH
SPEC.
MATL.
SPEC.

CLIP ASSEMBLY

DRAWN H.F.E.	DATE 27 NOV 68
APPR. PETE	DATE 3 DEC 68

UNLESS OTHERWISE SPECIFIED:

1. TOLERANCES:  
FRACTIONS ± .010 DECIMALS ± .004 ANGLES ± 0° 30'  
T. I. R. CONCENTRICITY OF ANY 2 DIAMETERS MAY NOT EXCEED THE SUM OF THEIR TOLERANCES.

2. REMOVE ALL BURRS, BREAK SHARP EDGES .005 MAX.
3. NO FILLETS PERMITTED.
4. SURFACE ROUGHNESS 63 MICROINCHES RMS MAX.
5. ALL DIMENSIONS PRIOR TO PLATING.

S-D K-2963-13