

## Ultrasoft Recovery Rectifier Diode

### PRODUCT APPLICATIONS

- Anti-Parallel Diode
  - Switchmode Power Supply
  - Inverters
- Applications
  - Induction Heating
- Resonant Mode Circuits
  - ZVS and ZCS Topologies
  - Phase Shifted Bridge

### PRODUCT FEATURES

- Ultrasoft Recovery Times ( $t_{rr}$ )
- Popular TO-247 Package or Surface Mount D<sup>3</sup>PAK Package
- Ultra Low Forward Voltage
- Low Leakage Current

### PRODUCT BENEFITS

- Soft Switching - High  $Q_{rr}$
- Low Noise Switching
  - Reduced Ringing
- Higher Reliability Systems
- Minimizes or eliminates snubber

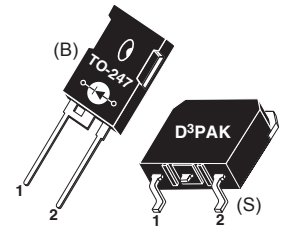

1 - Cathode  
 2 - Anode  
 Back of Case - Cathode

### MAXIMUM RATINGS

All Ratings:  $T_C = 25^\circ\text{C}$  unless otherwise specified.

Symbol	Characteristic / Test Conditions	Ratings	Unit
$V_R$	Maximum D.C. Reverse Voltage	600	Volts
$V_{RRM}$	Maximum Peak Repetitive Reverse Voltage		
$V_{RWM}$	Maximum Working Peak Reverse Voltage		
$I_{F(AV)}$	Maximum Average Forward current ( $T_C = 112^\circ\text{C}$ , Duty Cycle = 0.5)	75	Amps
$I_{F(RMS)}$	RMS Forward Current (Square wave, 50% duty)	121	
$I_{FSM}$	Non-Repetitive Forward Surge Current ( $T_J = 45^\circ\text{C}$ , 8.3 ms)	320	
$T_J, T_{STG}$	Operating and Storage Junction Temperature Range	-55 to 175	$^\circ\text{C}$
$T_L$	Lead Temperature for 10 Seconds	300	

### STATIC ELECTRICAL CHARACTERISTICS

Symbol	Characteristic / Test Conditions	Min	Typ	Max	Unit	
$V_F$	Forward Voltage		$I_F = 75\text{A}$	1.25	1.6	Volts
			$I_F = 150\text{A}$	2.0		
			$I_F = 75\text{A}, T_J = 125^\circ\text{C}$	1.25		
$I_{RM}$	Maximum Reverse Leakage Current		$V_R = 600\text{V}$		25	$\mu\text{A}$
			$V_R = 600\text{V}, T_J = 125^\circ\text{C}$		250	
$C_T$	Junction Capacitance, $V_R = 200\text{V}$		69		pF	

## DYNAMIC CHARACTERISTICS

APT75DL60B\_S(G)

Symbol	Characteristic / Test Conditions	Min	Typ	Max	Unit
$t_{rr}$	Reverse Recovery Time $I_F = 1A, di_F/dt = -100A/\mu s, V_R = 30V, T_J = 25^\circ C$		56		ns
$t_{rr}$	Reverse Recovery Time		460		
$Q_{rr}$	Reverse Recovery Charge		2174		
$I_{RRM}$	Maximum Reverse Recovery Current		11		Amps
$t_{rr}$	Reverse Recovery Time		597		ns
$Q_{rr}$	Reverse Recovery Charge		4326		
$I_{RRM}$	Maximum Reverse Recovery Current		15		
$t_{rr}$	Reverse Recovery Time		355		ns
$Q_{rr}$	Reverse Recovery Charge		7215		
$I_{RRM}$	Maximum Reverse Recovery Current		42		

## THERMAL AND MECHANICAL CHARACTERISTICS

Symbol	Characteristic / Test Conditions	Min	Typ	Max	Unit
$R_{\theta JC}$	Junction-to-Case Thermal Resistance			0.40	$^\circ C/W$
$W_T$	Package Weight		0.22		oz
			5.9		g
Torque	Maximum Mounting Torque			10	lb-in
				1.1	N-m

Microsemi reserves the right to change, without notice, the specifications and information contained herein.

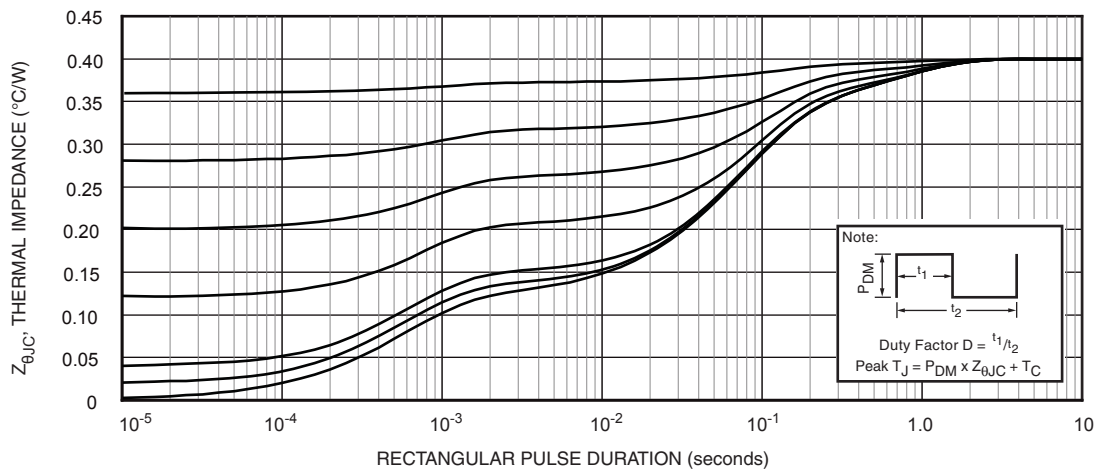
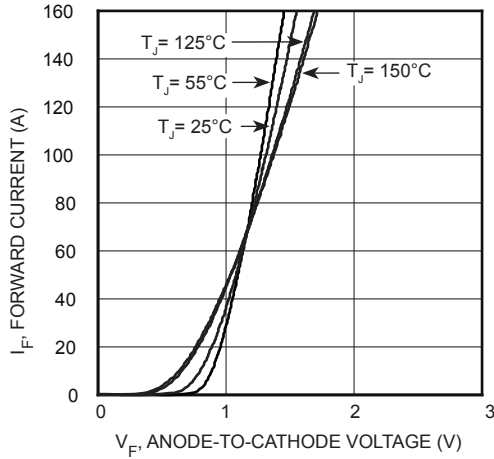

FIGURE 1. MAXIMUM EFFECTIVE TRANSIENT THERMAL IMPEDANCE, JUNCTION-TO-CASE vs. PULSE DURATION

**TYPICAL PERFORMANCE CURVES**

**APT75DL60B\_S(G)**



**FIGURE 2, Forward Current vs. Forward Voltage**

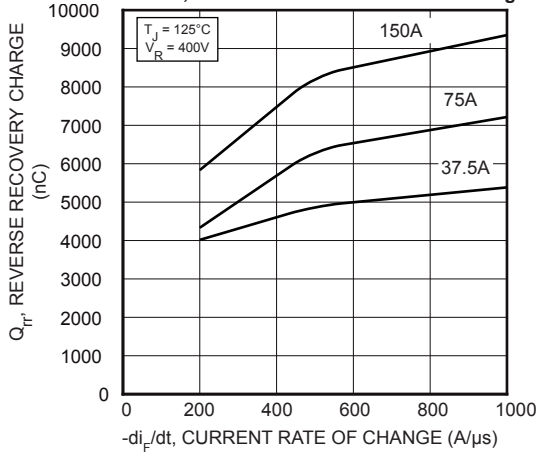

**FIGURE 4, Reverse Recovery Charge vs. Current Rate of Change**

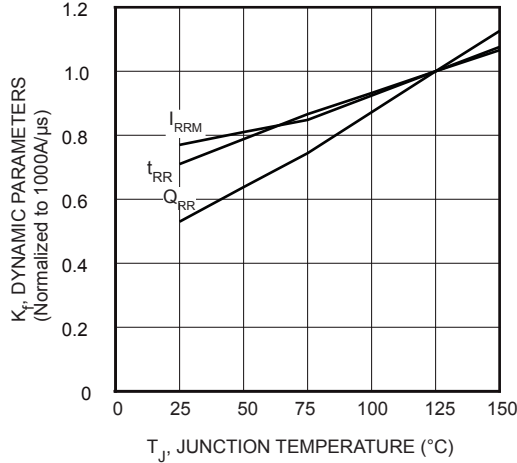

**FIGURE 6, Dynamic Parameters vs. Junction Temperature**

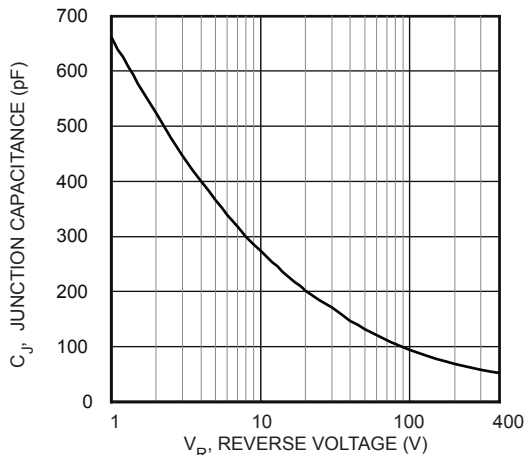

**FIGURE 8, Junction Capacitance vs. Reverse Voltage**

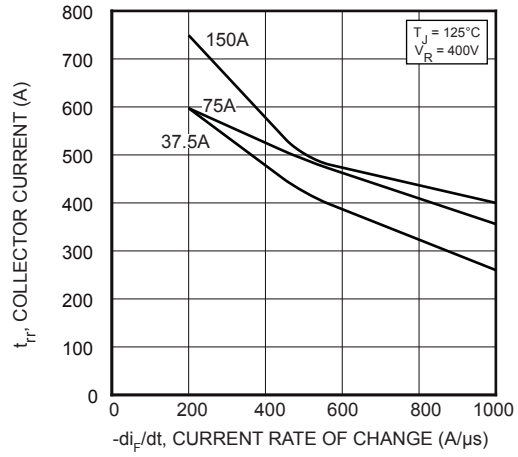

**FIGURE 3, Reverse Recovery Time vs. Current Rate of Change**

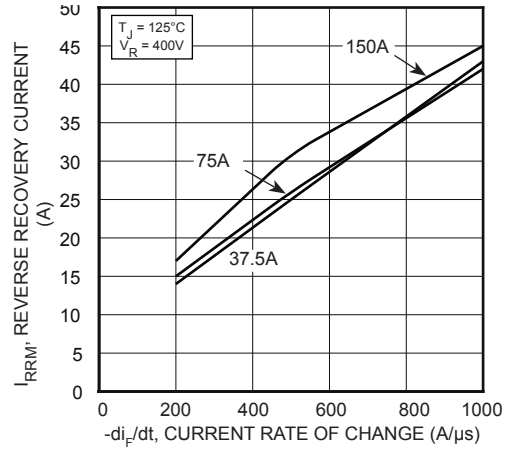

**FIGURE 5, Reverse Recovery Current vs. Current Rate of Change**

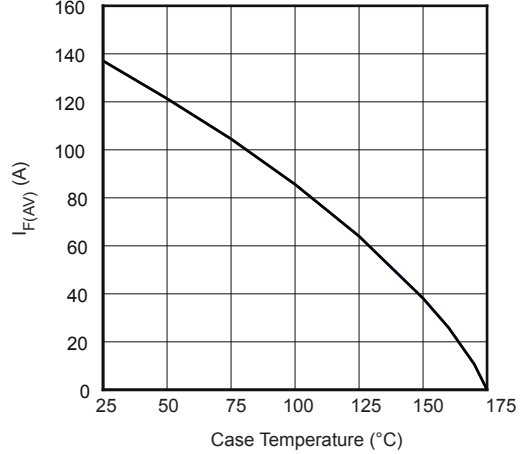

**FIGURE 7, Maximum Average Forward Current vs. Case Temperature**

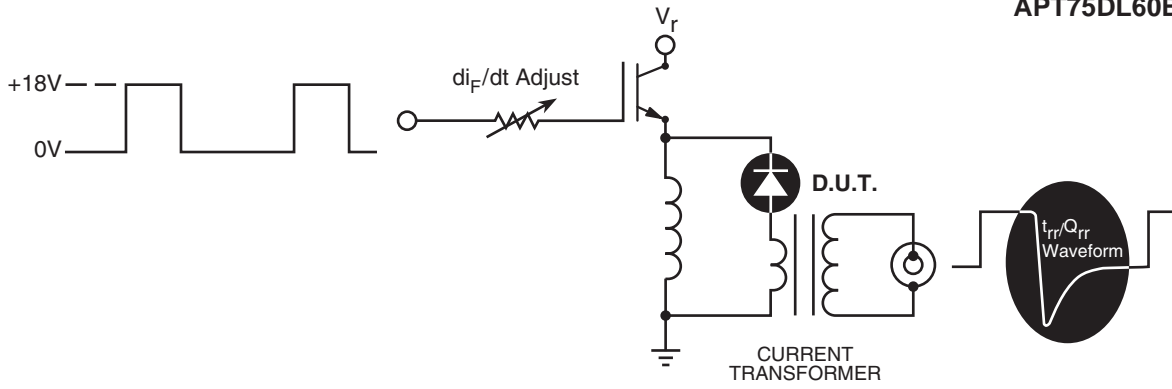

Figure 9. Diode Test Circuit

- 1  $I_F$  - Forward Conduction Current
- 2  $di_F/dt$  - Rate of Diode Current Change Through Zero Crossing.
- 3  $I_{RRM}$  - Maximum Reverse Recovery Current.
- 4  $t_{rr}$  - Reverse Recovery Time, measured from zero crossing where diode current goes from positive to negative, to the point at which the straight line through  $I_{RRM}$  and  $0.25 \cdot I_{RRM}$  passes through zero.
- 5  $Q_{rr}$  - Area Under the Curve Defined by  $I_{RRM}$  and  $t_{rr}$ .
- 6  $di_M/dt$  - Maximum Rate of Current Increase During the Trailing Portion of  $t_{rr}$ .

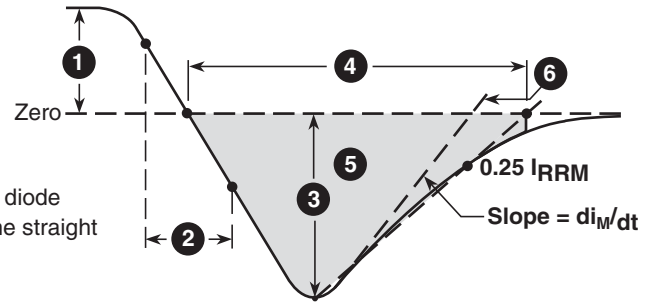
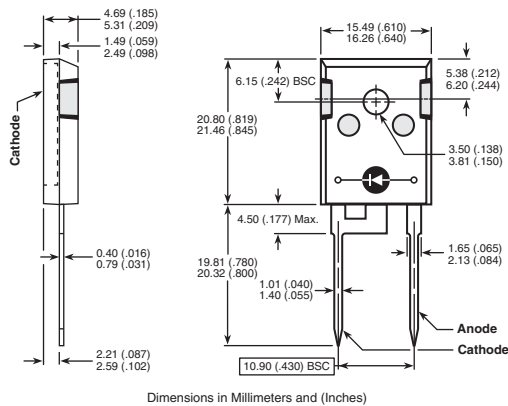

Figure 10, Diode Reverse Recovery Waveform and Definitions

### TO-247 Package Outline

e1 SAC: Tin, Silver, Copper



### D<sup>3</sup>PAK Package Outline

e1 100% Sn

